

THE CORPORATION OF THE TOWN OF CALEDON

BY-LAW NO. 91-86

A by-law to regulate the encumbering of highways during construction or repair.

WHEREAS paragraph 1 of section 210 of the Municipal Act, R.S.O. 1980, c.302 (as amended) authorizes the Council to pass by-laws for the purpose of regulating the temporary occupation of highways or portions thereof during the construction or repair of any work thereon.

NOW THEREFORE the Council of THE CORPORATION OF THE TOWN OF CALEDON enacts as follows:

1. In this by-law,
 - (a) "permit" means a Permit for the Installation/Relocation of Public Utilities and the General Conditions set out on the permit.
2. No person shall commence the construction or repair of any work over, on or under any highway in the Town of Caledon if the same will, or is likely to require the temporary occupation, obstructing, or encumbering of part or all of such highway until,
 - (a) a Permit is obtained from the Director of Public Works for the Town of Caledon; and
 - (b) signs and barricades have been erected; and
 - (c) alternate routes have been established.
3. The Permit referred to in Section 2 of this By-law shall be in the form annexed hereto as Schedule "A" and includes amendments to the form on Schedule "B".
4. An application for a Permit shall be made at least forty-eight (48) hours before the applicant commences any work referred to in Section 2.
5. Upon obtaining such Permit, and before commencing work, the applicant shall provide and maintain throughout the course of the work,
 - (a) a reasonable alternate route for through traffic and a suitable by-road for all owners or occupants who cannot obtain access to their property by any other public road, together with adequate direction signs;
 - (b) At either or both ends of the portion of the highway closed or partially closed, as the case may be, a substantial barricade or barricades shall be placed, upon which shall be exposed between sunset and dawn, such red or amber flashing lights. In addition, signs shall be posted indicating the alternate route.

6. All barricades, signs and lights shall be placed according to the Ministry of Transportation of Ontario's Manual of Uniform Traffic Control Devices, section A-5 "Temporary Conditions", or according to designs approved by the Director of Public Works. All costs for the said signage and lights shall be at the expense of the applicant.
7. In the event that the work is not completed by the date provided for in the Permit an application shall be made for an extension of time, at least seven (7) days prior to the expiry date stated on the Permit.
8. If the barricades, signs, and lights provided for herein are not installed and maintained, or if the road allowance is not restored or reinstated in accordance with the General Conditions stated on the permit, then the Director of Public Works shall carry out all necessary work as required at the cost and expense of the Permit holder, and the permit shall be deemed to have been cancelled, and the work shall not be recommenced until a new Permit is obtained and proper barricades, signs, lights and restoration as the case may be, are completed in accordance with the provision hereof and the same are approved by the Director of Public Works.
9. Every person who contravenes any provisions of this by-law is guilty of an offence, and liable upon conviction to a fine of not more than \$5,000.00, exclusive of costs, in respect of each offence.
10. By-law No. 74-36 is hereby repealed.

READ A FIRST, SECOND AND THIRD TIME, AND PASSED IN OPEN COUNCIL,
THIS 26th DAY OF August 1991.

Emil Kello
[Signature]
MAYOR
ACTING CLERK



TOWN OF CALEDON
PUBLIC WORKS DEPARTMENT
 P.O. BOX 1000, CALEDON EAST, ONT. L0N 1E0
 (416) 584-2273

**PERMIT FOR INSTALLATION/RELOCATION
 OF PUBLIC UTILITIES**

SCHEDULE "A"

UTILITY		DATE ISSUED Y M D			PERMIT NO.		
TYPE OF INSTALLATION		PROPOSED START DATE Y M D			BUILDING PERMIT NO.		
REPRESENTATIVE		PROPOSED COMPLETION DATE Y M D					
TELEPHONE NUMBER		PAVEMENT CUT YES <input type="checkbox"/> NO <input type="checkbox"/>			SIDEWALK CUT YES <input type="checkbox"/> NO <input type="checkbox"/>		
LOCATION OF WORK		WORK IN BLVD. OR DITCH YES <input type="checkbox"/> NO <input type="checkbox"/>			P.U.C.C. APPROVAL NO. (if applicable)		

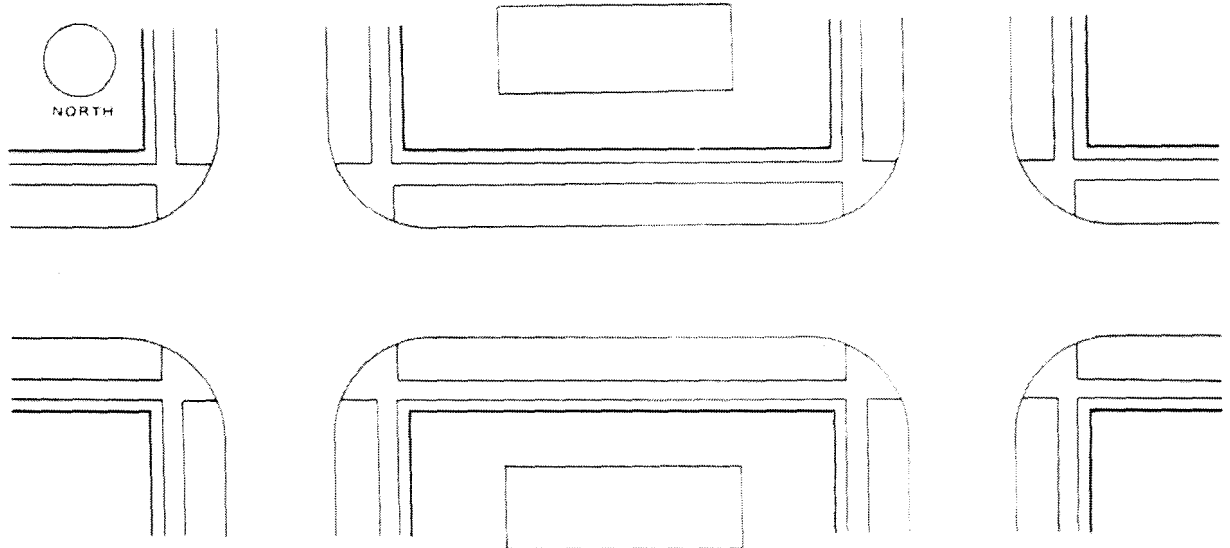

FAILURE TO COMPLY WILL RENDER THIS PERMIT VOID

NOTE:

1. PRIOR TO COMMENCING WORK, STAKE OUTS MUST BE OBTAINED FROM ALL UTILITIES IN THE TOWN OF CALEDON. ALL PIPE, CABLE, ETC. THAT IS EXPOSED OR UNDERMINED MUST BE SUPPORTED, BACKFILLED AND COMPACTED TO THE SATISFACTION OF THE UTILITY INVOLVED. (see over)
2. THE PUBLIC WORKS DEPT. MUST BE NOTIFIED 48 HOURS BEFORE WORK IS TO COMMENCE
3. WHEN WORKING, A COPY OF THIS PERMIT, CONDITIONS AND STAKEOUTS MUST BE ON SITE AT ALL TIMES.
4. THIS PERMIT IS NOT VALID UNTIL THE SIGNED COPY OF THE CONDITIONS IS RECEIVED BY THE TOWN OF CALEDON.
5. THE RETURN OF THE PERMIT TO THIS OFFICE IS NOTIFICATION OF COMPLETION OF WORK AND RESTORATION OF SITE.
6. A ONE YEAR GUARANTEE OF THE RESTORATION WILL DATE FROM THE TIME OF INSPECTION AND ACCEPTANCE OF THE REPAIRS BY THE DIRECTOR OF PUBLIC WORKS.

APPROVAL SUBJECT TO CONDITIONS ON REVERSE SIDE:

INSPECTOR'S COMMENTS	APPROVED BY
	DIRECTOR OF PUBLIC WORKS

INITIAL INSPECTION Y M D	INSPECTOR	FINAL INSPECTION Y M D	INSPECTOR
-----------------------------------	-----------	---------------------------------	-----------

WHITE-APPLICANT YELLOW-FILE PINK-FIELD

IMPORTANT - SEE REVERSE SIDE FOR CONDITIONS

SCHEDULE "B"

Amendment to
Permit for Installation/Relocation
of Public Utilities

GENERAL CONDITIONS

4. In grassed areas adjacent to homes, sodding is required. All other areas must be covered with a seed & mulch mixture. Topsoil must be replaced to a minimum of 50 mm depth and new sod must be counter sunk to match existing sod.
9. Property owners and/or residents must receive a minimum of 24 hours written notice prior to temporary closing of access to homes and businesses. Access can only be closed to a maximum of 24 hours.
10. All signs are to be placed as per the Ministry of Transportation Manual of Uniform Traffic Control Devices, section A-5 "temporary conditions".
12. Hot Mix and surface treated pavement must be restored as per detail "Trench Restoration".

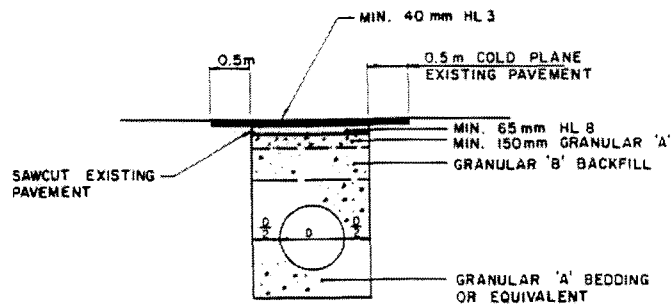

TRENCH RESTORATION

13. Granular bedding, cover, backfill and base courses must be compacted using mechanical tampers or vibrators to obtain a minimum dry density of 100% of the maximum dry density as determined by current M.T.O. procedure.

PERMIT # _____ UTILITY _____
CONTRACTOR _____ SIGNATURE _____