



TOWN OF CALEDON  
PLANNING  
RECEIVED  
April 23, 2026

## 4848 Mayfield Road Traffic Impact Study Report

Caledon, Ontario

Project Number: PTRAN2022029

---

Date: 10/20/2023

Prepared for:  
Glen Schnarr & Associates Inc.  
700 – 10 Kingsbridge Garden Circle  
Mississauga, ON L5R 3K6

Prepared by:  
TraffMobility Engineering Inc.  
9131 Keele Street, Unit A4  
Vaughan, ON L4K 0G7

This page is intentionally left blank.

### Document Revision History

Rev	Description	Prepared/ Revised By	Reviewed By	Approved By	Date Issued (M/D/Y)
R0	Draft Report for Review	A. Sathya	M. Ismatyar	T. Chow	10/17/2023
R1	Final Report for Submission	A. Sathya	M. Ismatyar	T. Chow	10/20/2023

Prepared by:

Ajhay Sathya, EIT



Reviewed by:

Mustafa Ismatyar, P.Eng.

Approved by:

Tavia Chow, M.A.Sc., MCIP, RPP, RSP1

## Contents

1.0	Introduction .....	1
1.1	Study Area .....	1
1.2	Study Methodology.....	2
1.3	Data Collection.....	2
2.0	Existing Conditions.....	3
2.1	Existing Intersection Operations.....	3
2.2	Pedestrian and Cyclist Infrastructure.....	5
2.3	Transit Services .....	5
3.0	Future Background Conditions .....	7
3.1	Future Planned Transportation Improvements .....	7
3.2	Future Traffic Growth .....	7
3.3	Future Background Developments .....	7
3.4	Future (2027) Background Intersection Operations.....	9
3.4.1	Proposed Mitigation Measures.....	11
3.5	Future (2032) Background Intersection Operations.....	12
3.5.1	Proposed Mitigation Measures.....	14
4.0	Proposed Development .....	15
4.1	Development Concept .....	15
4.2	Trip Generation.....	17
4.3	Trip Distribution .....	17
5.0	Future Total Conditions .....	18
5.1	Future (2027) Total Intersection Operations.....	18
5.1.1	Proposed Mitigation Measures.....	21
5.2	Future (2032) Total Intersection Operations.....	23
5.2.1	Proposed Mitigation Measures.....	25
6.0	Site Plan and Access Review .....	26
6.1	Site Plan and Access Review .....	26
6.2	Sightline Review.....	26
6.3	Site Circulation .....	26
7.0	Parking Review.....	26
8.0	Conclusions .....	27

## List of Tables

Table 1: Intersection Level of Service Criteria .....	2
Table 2: Turning Movement Counts .....	3
Table 3: Existing Conditions Intersection Operations.....	4
Table 4: Future (2027) Background Conditions Intersection Operations.....	10
Table 5: Future (2027) Background Conditions Intersection Operations with Mitigation .....	11
Table 6: Future (2032) Background Conditions Intersection Operations .....	13
Table 7: Future (2032) Background Conditions Intersection Operations with Mitigation .....	15
Table 8: Trip Generation Summary.....	17
Table 9: Trip Distribution Summary.....	17
Table 10: Future (2027) Total Conditions Intersection Operations .....	20
Table 11: Future (2027) Total Conditions Intersection Operations with Mitigation .....	22
Table 12: Future (2032) Total Conditions Intersection Operations .....	23
Table 13: Future (2032) Total Conditions Intersection Operations with Mitigation .....	25

## List of Figures

Figure 1: Site Location and Study Intersections.....	1
Figure 2: Existing Intersection Lane Configuration .....	3
Figure 3: Existing (2022) Adjusted Traffic Volumes .....	4
Figure 4: Existing Active Transportation Facilities .....	6
Figure 5: Existing Transit Services .....	6
Figure 6: 12035 Dixie Road Development Site Traffic .....	8
Figure 7: 12434 Dixie Road Development Site Traffic .....	8
Figure 8: 12892 Dixie Road Development Site Traffic .....	8
Figure 9: Background Developments Total Site Traffic.....	9
Figure 10: Future (2027) Background Traffic Volumes .....	9
Figure 11: Future (2032) Background Traffic Volumes .....	12
Figure 12: Site Concept Plan .....	16
Figure 13: Site Traffic .....	18
Figure 14: Future Lane Configuration .....	19
Figure 15: Future (2027) Total Traffic Volumes .....	19

Figure 16: Distance Between Medians ..... 22  
Figure 17: Future (2032) Total Traffic Volumes ..... 23

## List of Appendices

**Appendix A:** Existing Turning Movement Count Data

**Appendix B:** Existing Intersection Operation Calculations (Synchro)

**Appendix C:** Future (2027) Background Intersection Operation Calculations (Synchro)

**Appendix D:** Future (2032) Background Intersection Operation Calculations (Synchro)

**Appendix E:** Future (2027) Total Intersection Operation Calculations (Synchro)

**Appendix F:** WB-20 Tractor-Semitrailer Truck Movements at the Site Access

**Appendix G:** Future (2032) Total Intersection Operation Calculations (Synchro)

**Appendix H:** Swept Path Analysis

## 1.0 Introduction

TraffMobility Engineering Inc. (“TraffMobility”) was retained by Glen Schnarr & Associates Inc. to undertake a Traffic Impact Study (“TIS”) as part of the development application for the proposed development at 4848 Mayfield Road, Caledon, Ontario. The analysis approach, results, and findings are documented in this report. The study scope was discussed and confirmed with the Peel Region (“Region”) and the Town of Caledon (“Town”) staff.

### 1.1 Study Area

The subject site is located north of Mayfield Road approximately 360 metres west of Bramalea Road. The site location is shown in **Figure 1**.



*Figure 1: Site Location and Study Intersections*

The study area for the analysis includes the following key intersections:

- Mayfield Road at Bramalea Road,
- Mayfield Road at Dixie Road; and,
- Mayfield Road at Site Access.

## 1.2 Study Methodology

The study assessed traffic operations under existing (2022) conditions and the following future horizon years:

- Future (2027) Background Conditions (5-year horizon),
- Future (2027) Total Conditions (5-year horizon),
- Future (2032) Background Conditions (10-year horizon); and,
- Future (2032) Total Conditions (10-year horizon).

Intersection operations were assessed using the Synchro 11 software which utilizes the Highway Capacity Manual (HCM) methodology published by the Transportation Research Board National Research Council. Synchro 11 can analyze both signalized and unsignalized intersections in a road corridor or network considering the spacing, interaction, queues, and operations between intersections.

Intersection operations performance metrics are reported in terms of Level of Service (LOS), volume to capacity (v/c) ratios, and 95<sup>th</sup> percentile queues. Level of Service is based on the average control delay per vehicle for a given movement. Delay is an indicator of how long a vehicle must wait to complete a movement and is represented by a letter between 'A' and 'F', with 'F' being the longest delay. **Table 1** summarizes the LOS criteria for unsignalized intersections.

*Table 1: Intersection Level of Service Criteria*

Level of Service	Average Control Delay per Vehicle (second / vehicle)	
	Signalized Intersection	Unsignalized Intersection
A	≤ 10	≤ 10
B	>10 and ≤ 20	>10 and ≤ 15
C	> 20 and ≤ 35	> 15 and ≤ 25
D	> 35 and ≤ 55	> 25 and ≤ 35
E	> 55 and ≤ 80	> 35 and ≤ 50
F	> 80	> 50

The Synchro parameters used in the analysis are based on the *“Regional Guidelines for Using Synchro”*. Moreover, the following criteria was used to identify critical movements as outlined in the Region’s *“Traffic Impact Study Guidelines”*.

- *“Volume/capacity (V/C) ratios for overall intersection operations, through movements or shared through/turning movements increased to 0.90 or above”;*
- *“V/C ratios for exclusive movements that will exceed 1.00”;* and,
- *“95th percentile queue lengths for individual movements and do they exceed available lane storage”.*

A compound growth rate of 3.5% per annum was used in the analysis to estimate future traffic volumes. The growth rate was confirmed with the Region and Town staff.

## 1.3 Data Collection

Existing turning movement counts and signal timing plans for the study intersections were provided by the Region. Based on a comparison of 2016 and 2021 turning movement counts for the intersection of Bramalea Road / Mayfield Road, it was noted that 2016 traffic volumes were higher than 2021 traffic

volumes. Therefore, the analysis considered the 2016 turning movement count at this intersection under existing conditions (i.e., a conservative approach). The survey summary is provided in **Table 2** and a copy of the existing turning movement counts are provided in **Appendix A**.

Table 2: Turning Movement Counts

Intersection	Count Date	Source
Bramalea Road at Mayfield Road	November 29, 2016	Region
Dixie Road at Mayfield Road	June 1, 2022	Region

## 2.0 Existing Conditions

Traffic operations under existing conditions were analyzed for the peak hours during the weekday AM (7:00 am to 9:00 am) and weekday PM (4:00 pm to 6:00 pm) periods using the Synchro 11 software.

### 2.1 Existing Intersection Operations

Existing intersection operations were analyzed using the lane configurations illustrated in **Figure 2** and the existing (2022) adjusted traffic volumes shown in **Figure 3**. The analysis results are provided in **Table 3** and detailed calculations are provided in **Appendix B**.

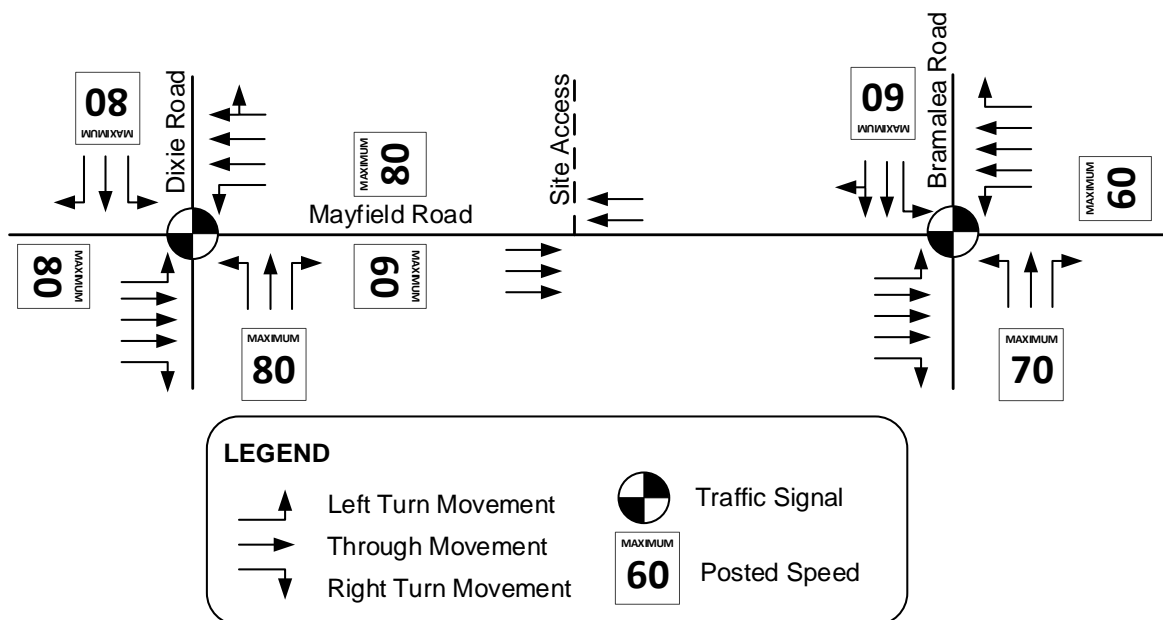

Figure 2: Existing Intersection Lane Configuration

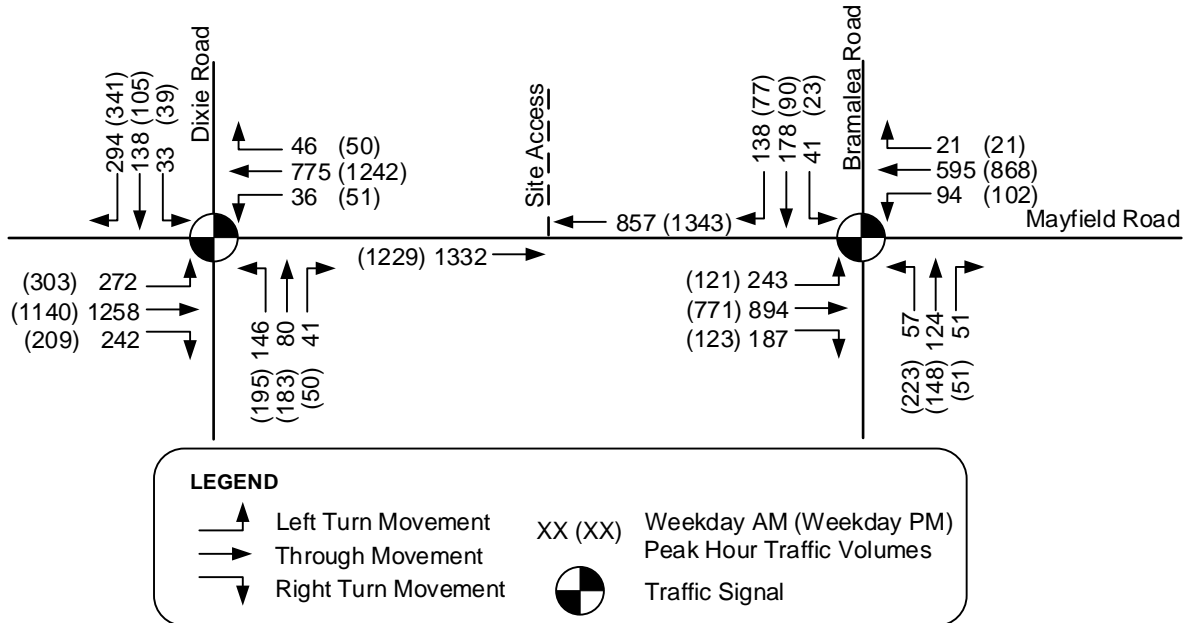

Figure 3: Existing (2022) Adjusted Traffic Volumes

Table 3: Existing Conditions Intersection Operations

Intersection / Movement	AM Peak Hour				PM Peak Hour				Available Storage (m)
	LOS	Delay (s)	v/c	95 <sup>th</sup> Percentile Queue (m)	LOS	Delay (s)	v/c	95 <sup>th</sup> Percentile Queue (m)	
<b>Bramalea Road at Mayfield Road (Signalized)</b>									
Overall	B	16	0.46	-	C	21	0.48	-	-
EBL	A	9	0.44	28	B	12	0.33	24	180
EBT	A	8	0.30	36	B	13	0.29	49	> 300
EBR	A	7	0.12	8	B	11	0.08	10	110
WBL	B	16	0.34	23	C	21	0.33	32	80
WBT	B	12	0.25	30	B	19	0.37	64	165
WBR	B	11	0.02	< 7	B	15	0.01	< 7	100
NBL	D	42	0.41	21	D	50	0.74	68	100
NBT	D	42	0.48	37	C	34	0.31	41	165
NBR	D	36	0.04	< 7	C	31	0.03	< 7	165
SBL	C	32	0.18	13	C	28	0.07	8	110
SBTR	C	33	0.29	24	C	28	0.11	14	> 200
<b>Dixie Road at Mayfield Road (Signalized)</b>									
Overall	B	20	0.60	-	C	28	0.69	-	-

Intersection / Movement	AM Peak Hour				PM Peak Hour				Available Storage (m)
	LOS	Delay (s)	v/c	95 <sup>th</sup> Percentile Queue (m)	LOS	Delay (s)	v/c	95 <sup>th</sup> Percentile Queue (m)	
EBL	A	9	0.55	34	C	28	0.66	72	170
EBT	B	12	0.42	75	B	14	0.42	74	270
EBR	A	9	0.16	11	B	12	0.13	12	100
WBL	B	11	0.14	< 7	B	18	0.19	9	150
WBTR	B	15	0.34	55	C	31	0.66	109	> 300
NBL	E	59	0.71	47	D	53	0.70	57	125
NBT	D	43	0.24	26	D	42	0.45	49	> 300
NBR	D	40	0.03	< 7	D	37	0.03	< 7	50
SBL	D	42	0.16	14	D	39	0.18	15	80
SBT	D	45	0.42	41	D	40	0.26	30	> 200
SBR	D	45	0.37	33	D	42	0.37	33	180

Note: LOS – level of service, v/c – volume to capacity ratio

The analysis results in **Table 3** indicate that all movements at the study intersection are operating with acceptable level of service and residual capacity during the weekday AM and weekday PM peak hours under existing conditions. Moreover, the analysis results indicate that 95<sup>th</sup> percentile queues can be accommodated within the available storage under existing conditions.

## 2.2 Pedestrian and Cyclist Infrastructure

Currently, sidewalks are provided on both sides along Bramalea Road south of Mayfield Road. Moreover, a multi-use path is provided on the south side of Mayfield Road as illustrated in **Figure 4**.

## 2.3 Transit Services

The bus routes within the study area is Route 15 and Route 18. Route 15 operates with a service headway of twenty (20) minutes. Route 18 operates with a service headway of five (5) to fifteen (15) minutes during the AM peak periods and nine (9) minutes during the PM Peak period as shown in **Figure 5**.

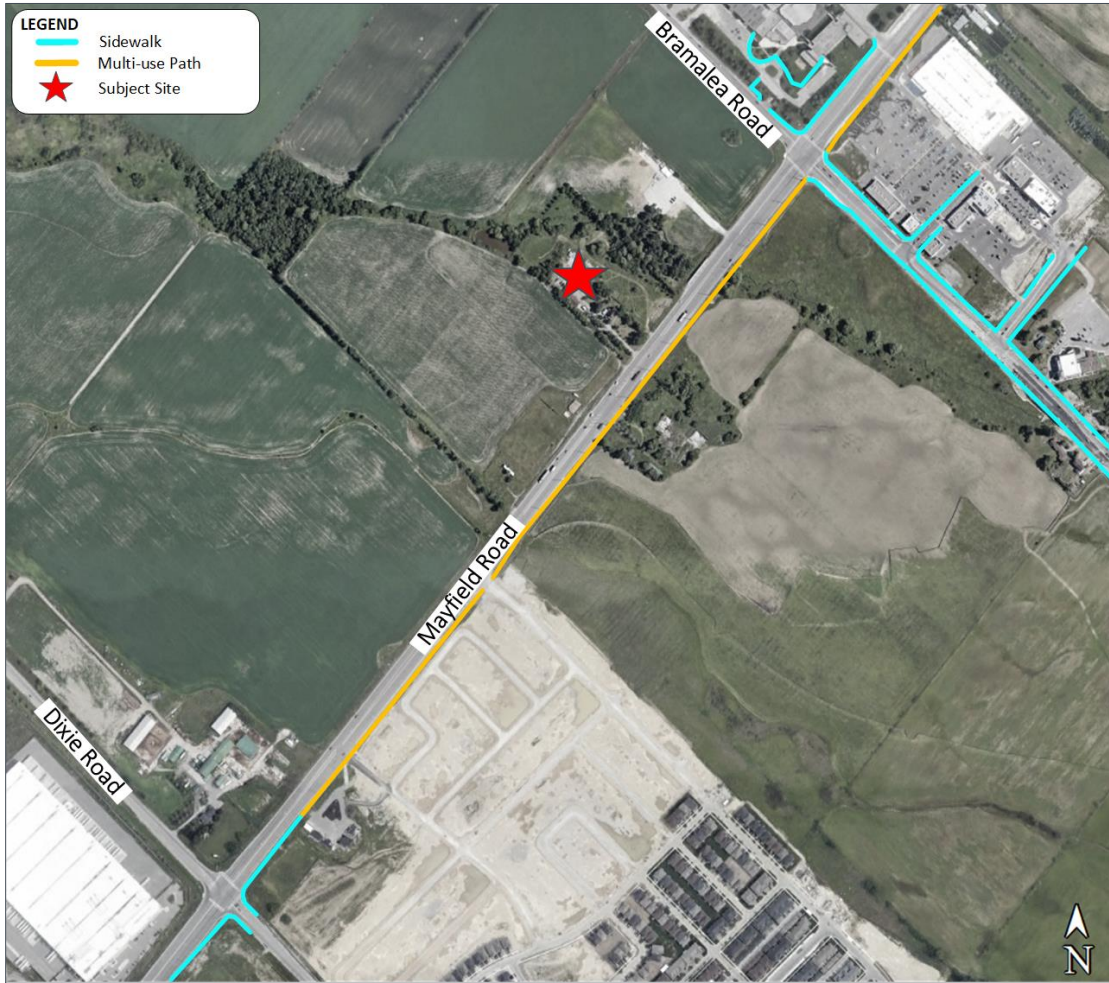

Figure 4: Existing Active Transportation Facilities

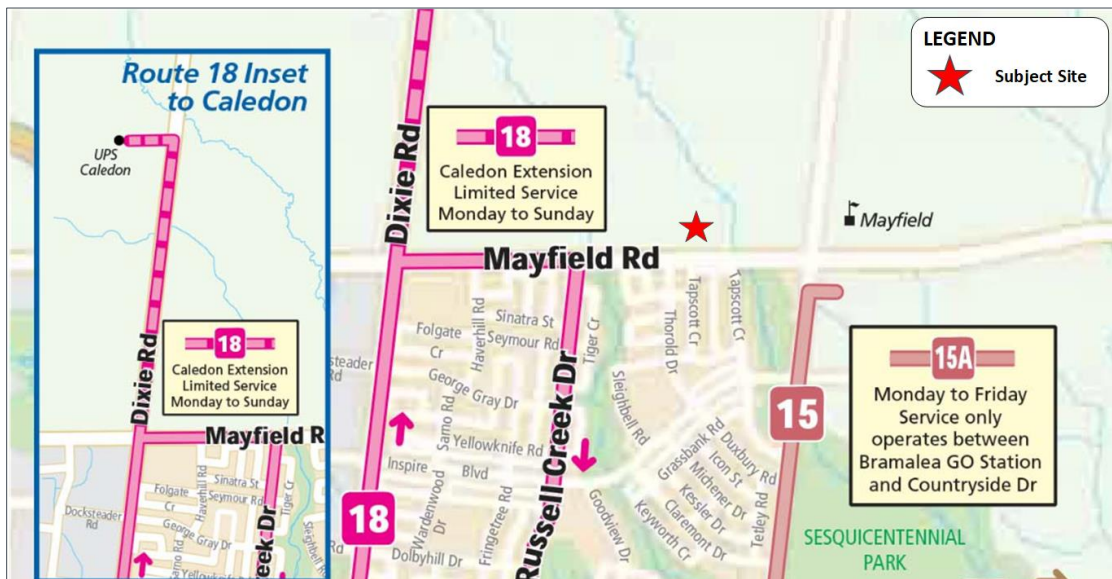

Figure 5: Existing Transit Services

### 3.0 Future Background Conditions

The future 2027 and 2032 horizon years were selected and confirmed with the Region and Town staff. The future background conditions assessment is based on projected background growth and transportation improvements planned for the study area corresponding to the horizon years, if applicable. Traffic operations under future background conditions were analyzed for the weekday AM and weekday PM peak hours using the Synchro 11 software.

#### 3.1 Future Planned Transportation Improvements

It is noted that no roadway or intersection improvements are planned on Mayfield Road in the vicinity of the study area by the horizon year of 2032.

#### 3.2 Future Traffic Growth

Future background traffic for the study area consists of two components: traffic growth outside the study area and other development site traffic within the study area. A compound growth rate of 3.5% per annum was used in the analysis to estimate future traffic volumes. This growth rate was confirmed with the Region and Town staff.

#### 3.3 Future Background Developments

Based on consultations with the Town staff, the following background developments were identified and considered in the study. It was assumed that all background developments would be fully built out by the horizon year of 2027.

1. 12035 Dixie Road - 4 warehouse/distribution buildings with a combined GFA of 200,292 m<sup>2</sup>
2. 12434 Dixie Road - A transport truck/trailer parking facility on the 10.7 Ha site
3. 12892 Dixie Road - 4 warehouse/distribution buildings with a combined GFA of 247,243 m<sup>2</sup>.

The site trips for each of the above-noted developments are provided in **Figure 6** to **Figure 8** and the total site trips are illustrated in **Figure 9**.

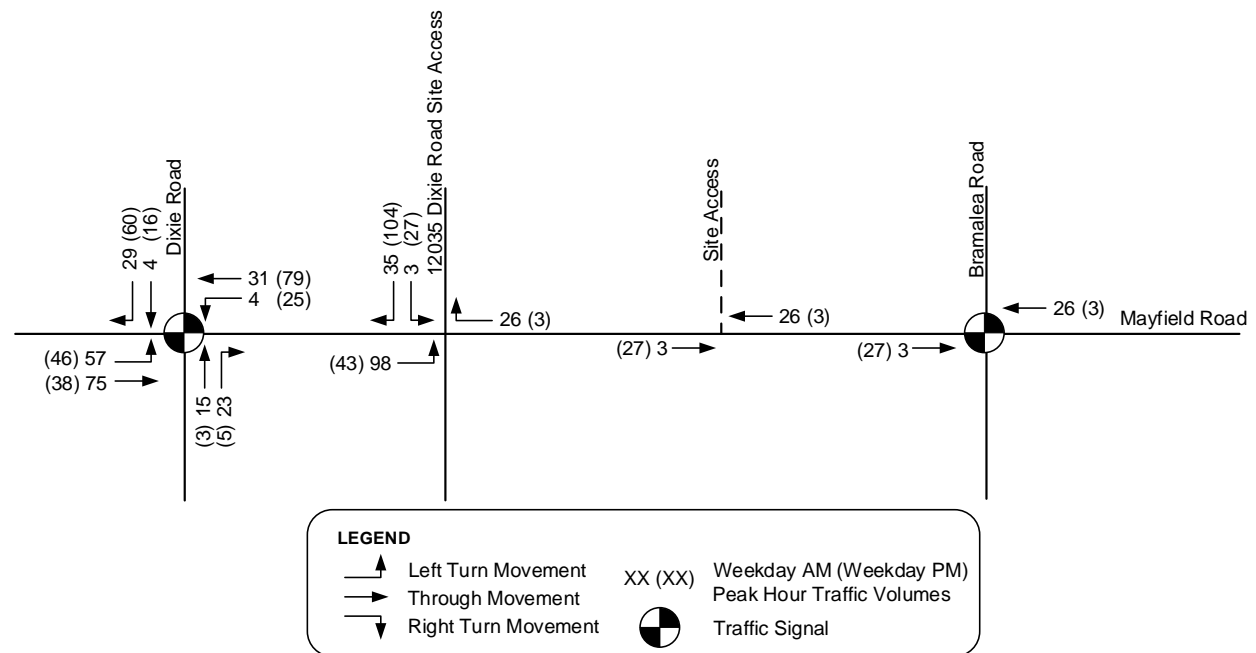

Figure 6: 12035 Dixie Road Development Site Traffic

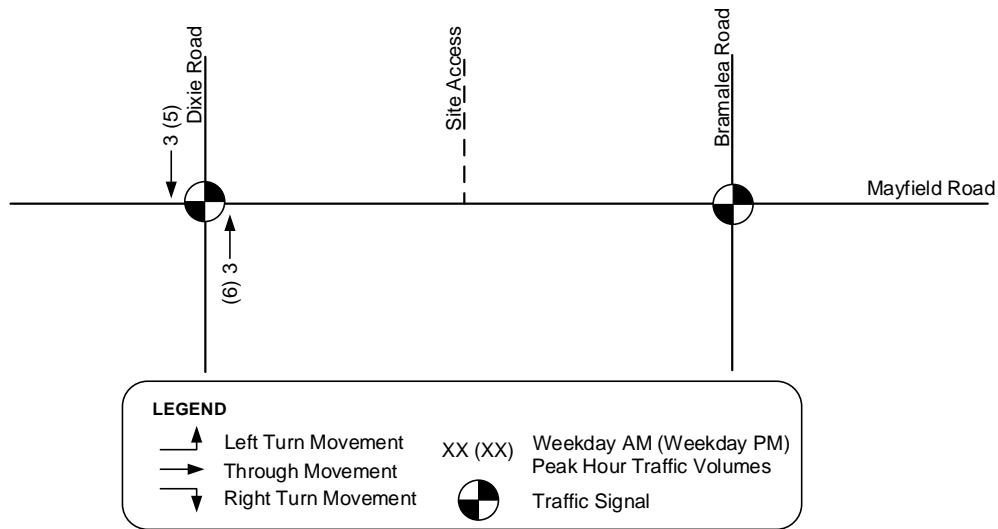

Figure 7: 12434 Dixie Road Development Site Traffic

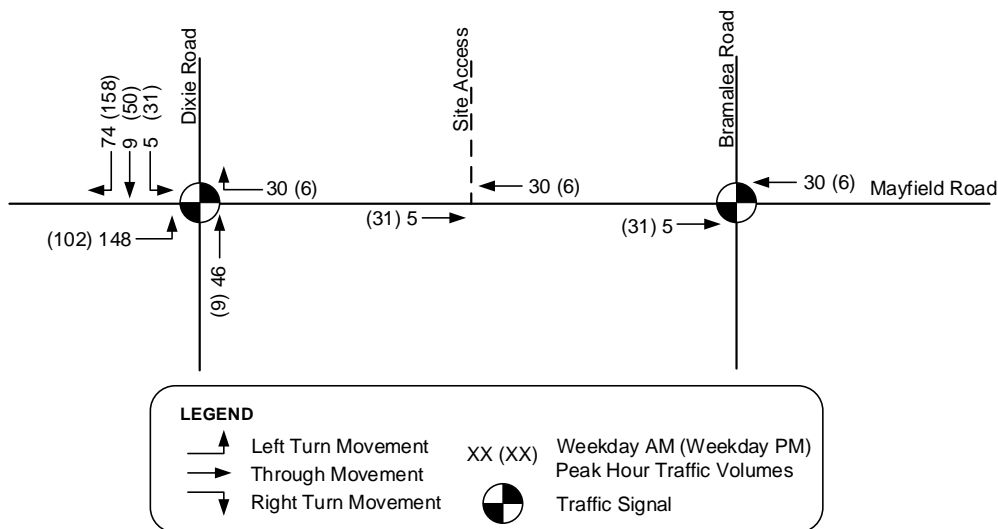

Figure 8: 12892 Dixie Road Development Site Traffic

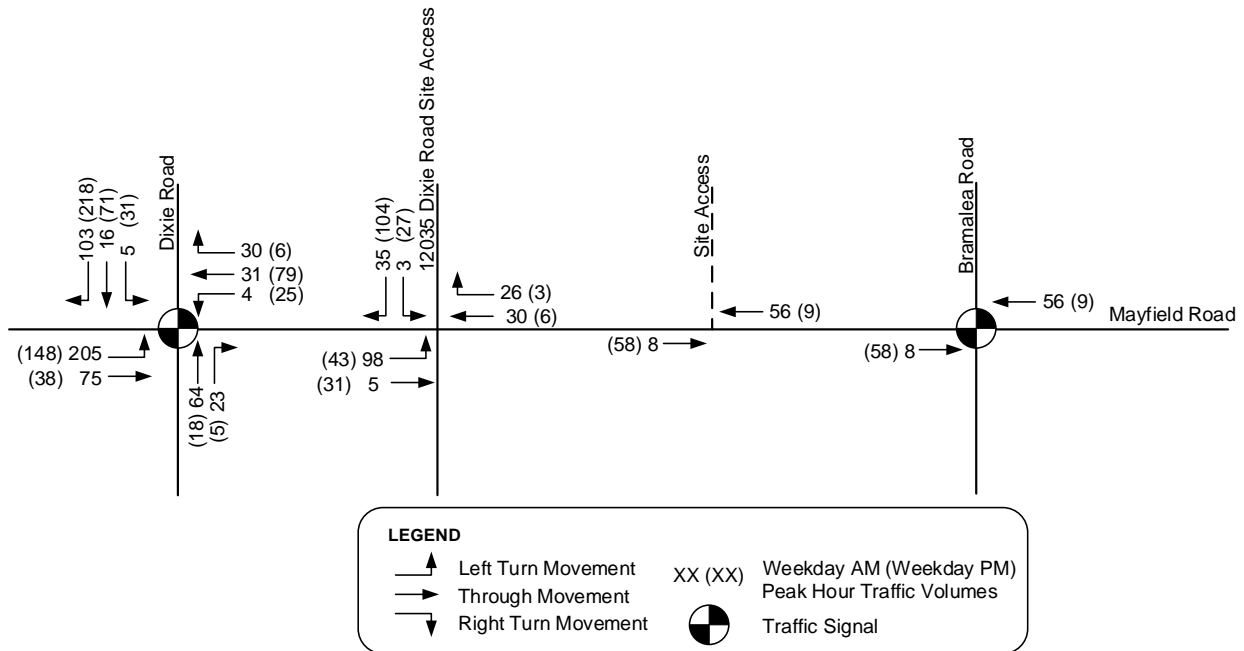

Figure 9: Background Developments Total Site Traffic

### 3.4 Future (2027) Background Intersection Operations

Future (2027) background traffic volumes were estimated using a compound growth rate of 3.5% per annum applied to the existing traffic volumes (Figure 3) plus the background developments total site traffic (Figure 9). The resulting future (2027) background traffic volumes are illustrated in Figure 10.

Future (2027) background intersection operations were analyzed using the existing lane configurations illustrated in Figure 2 and the future (2027) background traffic volumes shown in Figure 10. The analysis results are provided in Table 4 and detailed calculations are provided in Appendix C.

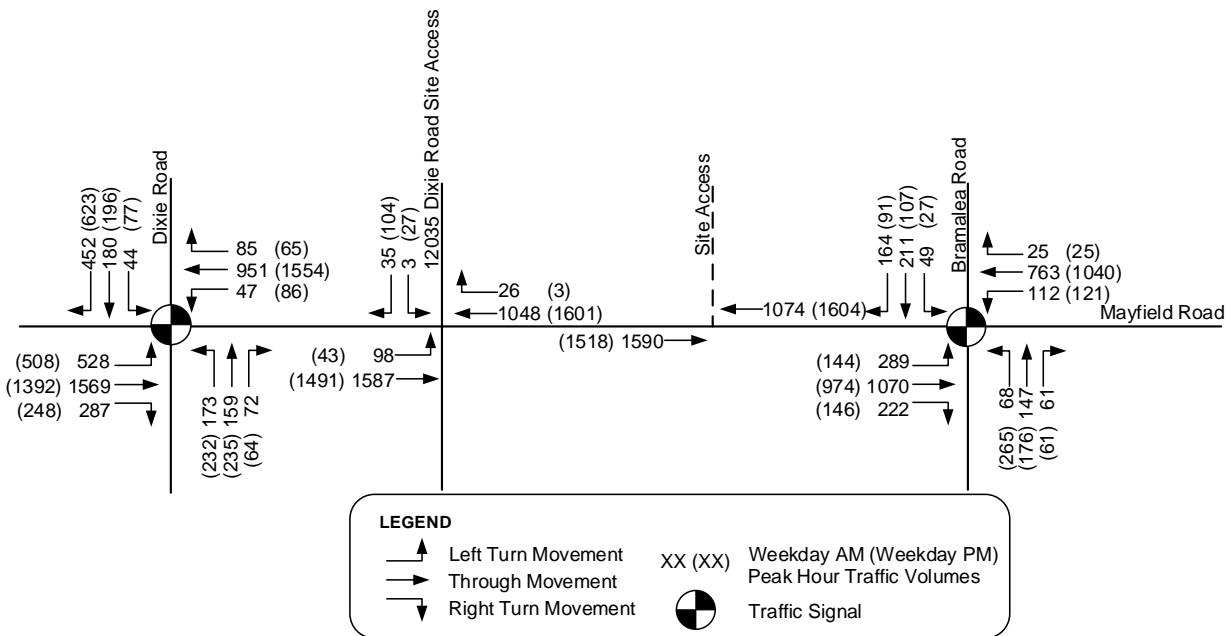

Figure 10: Future (2027) Background Traffic Volumes

Table 4: Future (2027) Background Conditions Intersection Operations

Intersection / Movement	AM Peak Hour				PM Peak Hour				Available Storage (m)
	LOS	Delay (s)	v/c	95 <sup>th</sup> Percentile Queue (m)	LOS	Delay (s)	v/c	95 <sup>th</sup> Percentile Queue (m)	
<b>Bramalea Road at Mayfield Road (Signalized)</b>									
Overall	B	17	0.61	-	C	24	0.61	-	-
EBL	B	13	0.63	37	B	18	0.51	32	180
EBT	A	10	0.37	49	B	16	0.39	72	> 300
EBR	A	8	0.15	9	B	14	0.09	11	110
WBL	C	23	0.50	34	C	31	0.51	47	80
WBT	B	14	0.33	42	C	23	0.48	89	165
WBR	B	12	0.02	< 7	B	18	0.02	< 7	100
NBL	D	44	0.47	24	D	54	0.80	82	100
NBT	D	43	0.52	43	C	34	0.32	47	165
NBR	D	36	0.04	7	C	31	0.04	6	165
SBL	C	31	0.20	15	C	26	0.07	9	110
SBTR	C	32	0.31	28	C	27	0.12	15	> 200
<b>Dixie Road at Mayfield Road (Signalized)</b>									
Overall	D	38	<b>1.03</b>	-	E	61	<b>1.27</b>	-	-
EBL	<b>F</b>	99	<b>1.10</b>	<b>206</b>	<b>F</b>	260	<b>1.46</b>	<b>214</b>	170
EBT	B	20	0.61	124	C	26	0.63	106	270
EBR	B	15	0.19	15	B	19	0.16	14	100
WBL	C	28	0.26	14	B	19	0.46	11	150
WBTR	D	37	0.62	92	D	55	<b>1.00</b>	162	> 300
NBL	D	46	0.63	47	D	38	0.62	63	125
NBT	D	37	0.33	38	C	31	0.37	55	> 300
NBR	C	33	0.05	< 7	C	27	0.04	< 7	50
SBL	C	35	0.17	14	C	29	0.24	22	80
SBT	D	37	0.39	43	C	30	0.31	46	> 200
SBR	D	51	0.77	77	E	57	0.89	140	180
<b>Mayfield Road at 12035 Dixie Road Access (Signalized)</b>									
Overall	A	8	0.39	-	A	10	0.60	-	-
EBL	A	9	0.24	32	A	10	0.24	8	50
EBT	A	10	0.40	126	A	8	0.42	66	> 200

Intersection / Movement	AM Peak Hour				PM Peak Hour				Available Storage (m)
	LOS	Delay (s)	v/c	95 <sup>th</sup> Percentile Queue (m)	LOS	Delay (s)	v/c	95 <sup>th</sup> Percentile Queue (m)	
EBR	A	-	0.00	< 7	A	-	0.00	< 7	60
WBL	A	-	0.00	< 7	A	-	0.00	< 7	60
WBTR	A	3	0.41	39	A	7	0.62	107	> 200
NBLTR	A	-	0.00	< 7	A	-	0.00	< 7	> 200
SBLTR	E	56	0.06	11	D	54	0.52	37	> 200

Note: LOS – level of service, v/c – volume to capacity ratio

The analysis results in **Table 4** indicate that all movements at the study intersection are expected to operate with acceptable level of service and residual capacity during the weekday AM and weekday PM peak hours under future (2027) background conditions except the following movements:

- Dixie Road at Mayfield Road
  - Eastbound left movement during the weekday AM and PM peak hours
  - Westbound through-right movement during the PM peak hour

### 3.4.1 Proposed Mitigation Measures

Based on the analysis results provided in **Table 4**, the following mitigation measures are proposed under future (2027) background conditions.

- Dixie Road at Mayfield Road
  - Increase the cycle length from 120 seconds to 130 seconds and 150 seconds during the weekday AM and weekday PM peak hours, respectively.
  - Increase the storage for the eastbound left movement from 170 metres to 215 metres.

The analysis results with mitigation are provided in **Table 5** and detailed calculations are provided in **Appendix C**.

Table 5: Future (2027) Background Conditions Intersection Operations with Mitigation

Intersection / Movement	AM Peak Hour				PM Peak Hour				Available Storage (m)
	LOS	Delay (s)	v/c	95 <sup>th</sup> Percentile Queue (m)	LOS	Delay (s)	v/c	95 <sup>th</sup> Percentile Queue (m)	
<b>Dixie Road at Mayfield Road (Signalized)</b>									
Overall	C	33	0.86	-	D	54	0.99	-	-
EBL	D	40	0.85	179	F	87	<b>1.00</b>	213	215
EBT	B	17	0.55	118	C	21	0.53	105	270
EBR	B	12	0.19	14	B	16	0.16	13	100
WBL	C	28	0.28	9	C	32	0.41	16	150

Intersection / Movement	AM Peak Hour				PM Peak Hour				Available Storage (m)
	LOS	Delay (s)	v/c	95 <sup>th</sup> Percentile Queue (m)	LOS	Delay (s)	v/c	95 <sup>th</sup> Percentile Queue (m)	
WBTR	D	42	0.72	94	E	73	1.00	196	> 300
NBL	E	72	0.82	58	F	88	0.91	98	125
NBT	D	45	0.40	46	D	48	0.48	75	> 300
NBR	D	40	0.05	9	D	41	0.04	9	50
SBL	D	43	0.21	17	D	47	0.36	31	80
SBT	D	46	0.46	52	D	47	0.40	63	> 200
SBR	D	46	0.44	39	E	62	0.77	105	180

Note: LOS – level of service, v/c – volume to capacity ratio

### 3.5 Future (2032) Background Intersection Operations

Future (2032) background traffic volumes were estimated using a compound growth rate of 3.5% per annum applied to the existing traffic volumes (Figure 3) plus the background developments total site traffic (Figure 9). The resulting future (2032) background traffic volumes are illustrated in Figure 10.

Future (2032) background intersection operations were analyzed using the existing lane configurations illustrated in Figure 2 and the future (2032) background traffic volumes shown in Figure 11. The analysis results are provided in Table 6 and detailed calculations are provided in Appendix D.

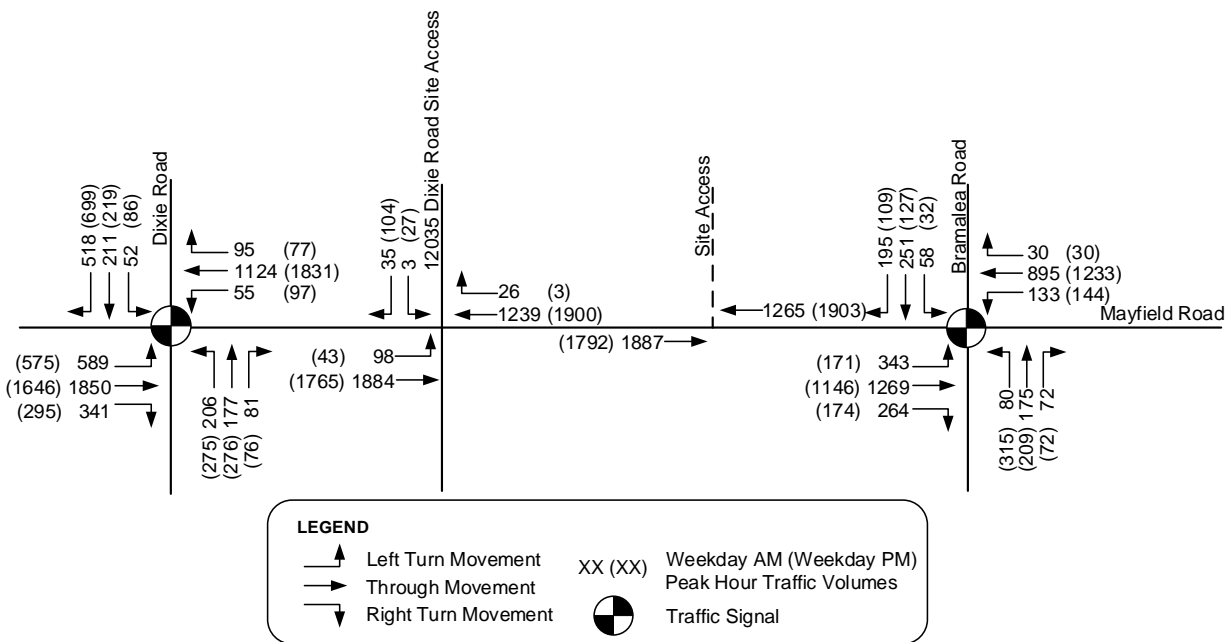

Figure 11: Future (2032) Background Traffic Volumes

Table 6: Future (2032) Background Conditions Intersection Operations

Intersection / Movement	AM Peak Hour				PM Peak Hour				Available Storage (m)
	LOS	Delay (s)	v/c	95 <sup>th</sup> Percentile Queue (m)	LOS	Delay (s)	v/c	95 <sup>th</sup> Percentile Queue (m)	
<b>Bramalea Road at Mayfield Road (Signalized)</b>									
Overall	C	21	0.80	-	C	30	0.81	-	-
EBL	C	32	0.87	69	D	39	0.79	53	180
EBT	B	11	0.44	65	C	21	0.48	88	> 300
EBR	A	9	0.17	10	B	16	0.11	12	110
WBL	D	44	0.74	57	E	59	0.79	73	80
WBT	B	16	0.39	53	C	29	0.60	109	165
WBR	B	12	0.03	<7	C	21	0.02	<7	100
NBL	D	46	0.54	28	E	60	0.87	104	100
NBT	D	43	0.56	50	C	33	0.34	56	165
NBR	D	36	0.05	9	C	29	0.05	8	165
SBL	C	31	0.24	17	C	25	0.08	10	110
SBTR	C	32	0.38	35	C	26	0.14	17	> 200
<b>Dixie Road at Mayfield Road (Signalized)</b>									
Overall	E	66	<b>1.37</b>	-	F	106	<b>1.58</b>	-	-
EBL	F	323	<b>1.62</b>	<b>253</b>	F	492	<b>1.98</b>	<b>247</b>	170
EBT	C	28	0.79	162	D	35	0.83	135	270
EBR	B	18	0.22	16	C	22	0.19	15	100
WBL	C	31	0.40	15	C	30	0.60	13	150
WBTR	D	39	0.73	113	F	118	<b>1.18</b>	210	> 300
NBL	D	43	0.66	58	D	38	0.69	79	125
NBT	C	32	0.31	42	C	28	0.39	64	> 300
NBR	C	29	0.06	8	C	24	0.05	7	50
SBL	C	30	0.17	16	C	27	0.25	25	80
SBT	C	33	0.38	50	C	27	0.31	51	> 200
SBR	D	52	0.83	104	E	67	0.96	177	180
<b>Mayfield Road at 12035 Dixie Road Development Access (Signalized)</b>									
Overall	A	9	0.46	-	B	12	0.70	-	-
EBL	B	11	0.30	25	B	17	0.38	7	50
EBT	B	13	0.47	151	B	11	0.49	90	> 200

Intersection / Movement	AM Peak Hour				PM Peak Hour				Available Storage (m)
	LOS	Delay (s)	v/c	95 <sup>th</sup> Percentile Queue (m)	LOS	Delay (s)	v/c	95 <sup>th</sup> Percentile Queue (m)	
EBR	A	-	0.00	< 7	A	-	0.00	< 7	60
WBL	A	-	0.00	< 7	A	-	0.00	< 7	60
WBTR	A	3	0.48	50	A	9	0.73	152	> 200
NBLTR	A	-	0.00	< 7	A	-	0.00	< 7	> 200
SBLTR	E	56	0.06	11	D	54	0.52	37	> 200

Note: LOS – level of service, v/c – volume to capacity ratio

The analysis results in **Table 6** indicate that all movements at the study intersection are expected to operate with acceptable level of service and residual capacity during the weekday AM and weekday PM peak hours under future (2032) background conditions except the following movements similar to future (2027) background conditions:

- Dixie Road at Mayfield Road
  - Eastbound left movement during the weekday AM and PM peak hours
  - Westbound through-right movement during the PM peak hour

### 3.5.1 Proposed Mitigation Measures

Based on the analysis results provided in **Table 6**, in addition to the mitigation measures proposed under future (2027) background conditions, the following additional mitigation measures are proposed under future (2032) background conditions.

- Dixie Road at Mayfield Road
  - Increase the cycle length from 130 seconds to 150 seconds during the weekday AM peak hour.
  - Provide an additional left turn lane in the eastbound direction and widen the north leg to accommodate two receiving lanes.
  - Provide a protected-permissive southbound right phase overlapped with the eastbound left phase.
  - Increase the storage for the southbound right movement from 180 metres to 255 metres.

The analysis results with mitigation are provided in **Table 7** and detailed calculations are provided in **Appendix D**.

Table 7: Future (2032) Background Conditions Intersection Operations with Mitigation

Intersection / Movement	AM Peak Hour				PM Peak Hour				Available Storage (m)
	LOS	Delay (s)	v/c	95 <sup>th</sup> Percentile Queue (m)	LOS	Delay (s)	v/c	95 <sup>th</sup> Percentile Queue (m)	
<b>Dixie Road at Mayfield Road (Signalized)</b>									
Overall	C	34	0.79	-	D	49	0.98	-	-
EBL	C	31	0.72	66	E	70	0.93	104	215
EBT	C	22	0.66	152	C	28	0.68	141	270
EBR	B	15	0.22	14	B	20	0.19	14	100
WBL	C	26	0.40	12	C	28	0.52	19	150
WBTR	D	36	0.65	133	E	55	0.96	218	> 300
NBL	F	92	0.91	90	F	90	0.95	122	125
NBT	D	47	0.38	58	D	44	0.49	86	> 300
NBR	D	42	0.06	10	D	37	0.05	11	50
SBL	D	45	0.22	22	D	43	0.37	34	80
SBT	D	49	0.46	68	D	42	0.38	68	> 200
SBR	D	47	0.36	30	E	71	0.99	251	255

Note: LOS – level of service, v/c – volume to capacity ratio

## 4.0 Proposed Development

### 4.1 Development Concept

The proposed development, located at north of Mayfield Road approximately 360 metres west of Bramalea Road. The proposed site will consist of a total of 15 transport truck/trailer parking facility. The site concept plan is shown in **Figure 12**.

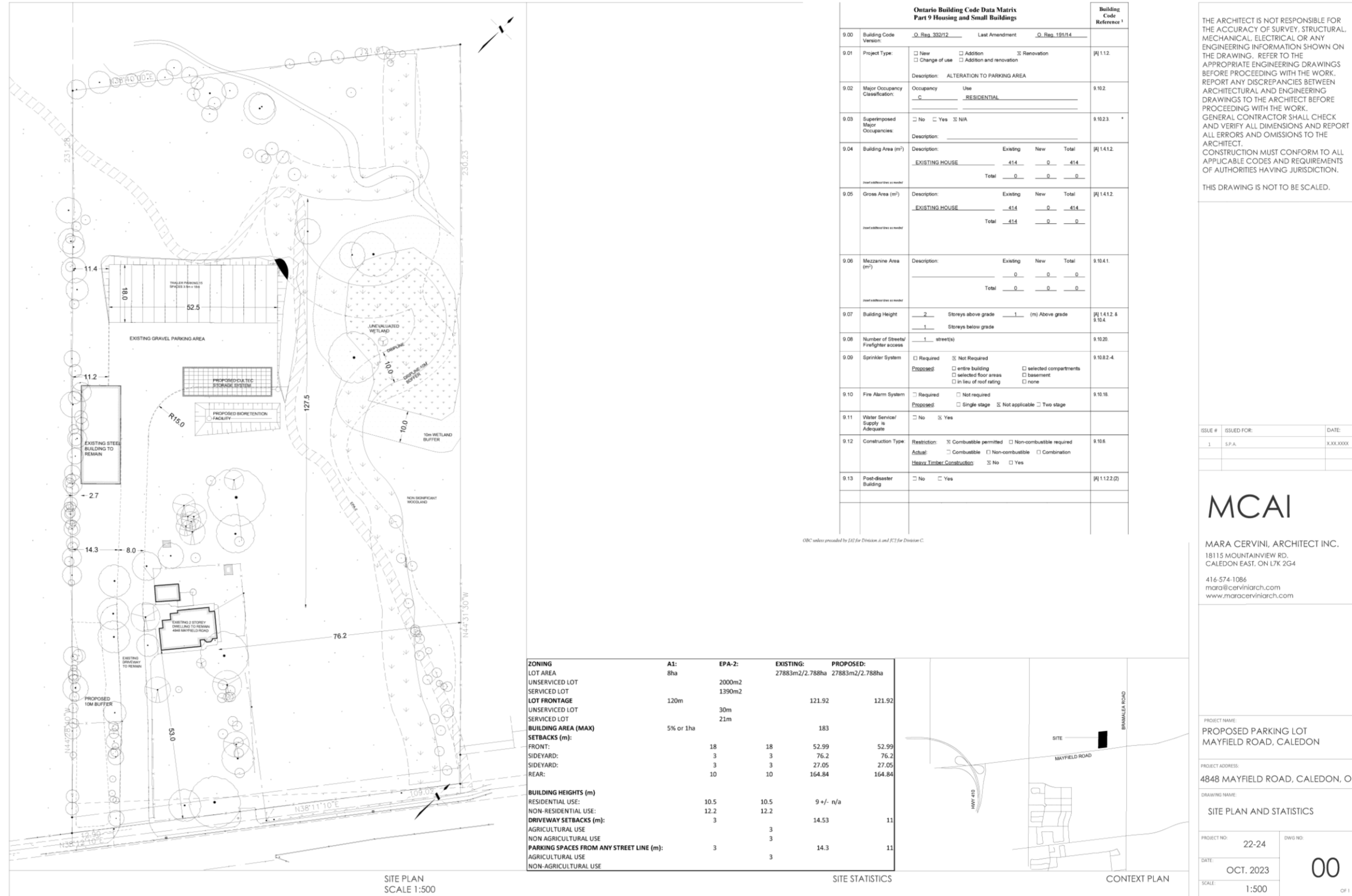

Figure 12: Site Concept Plan

## 4.2 Trip Generation

A total of 15 transport truck/trailer parking spaces will be provided on site. For the purposes of the analysis, it was assumed that all site generated trips will leave the site during the weekday AM peak hour and return to the site during the weekday PM peak hour (i.e., a conservative approach). The projected trip generation estimates for the subject site are summarized in **Table 8**.

*Table 8: Trip Generation Summary*

Use	No. of Parking Spaces	Parameter	AM Peak Hour			PM Peak Hour		
			In	Out	Total	In	Out	Total
Parking Facility	15	Gross Trips	0	15	15	15	0	15
		<b>Net Trips</b>	<b>0</b>	<b>15</b>	<b>15</b>	<b>15</b>	<b>0</b>	<b>15</b>

## 4.3 Trip Distribution

The trip distribution for the proposed development is based on the existing travel patterns. The resulting trip distribution is summarized in **Table 9**.

*Table 9: Trip Distribution Summary*

From / To	Via	Inbound	Outbound
North	Bramalea Road	10%	10%
	Dixie Road	10%	10%
South	Bramalea Road	12%	12%
	Dixie Road	11%	11%
East	Mayfield Road	26%	26%
West	Mayfield Road	31%	31%
<b>Total</b>		<b>100%</b>	<b>100%</b>

The resulting site generated trips are illustrated in **Figure 13**.

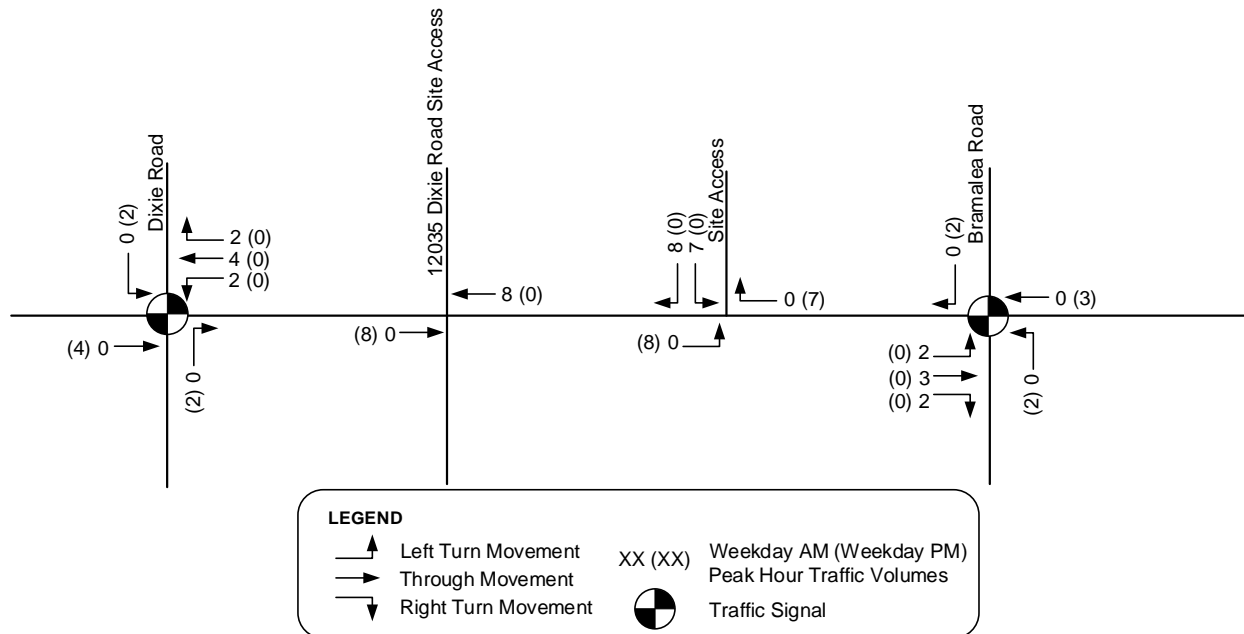

Figure 13: Site Traffic

## 5.0 Future Total Conditions

Traffic operations under future (2027) total conditions were analyzed for the weekday AM and weekday PM peak hours using the Synchro 11 software. The traffic analysis and results for the future total conditions are discussed in this section.

### 5.1 Future (2027) Total Intersection Operations

Future (2027) total intersection operations were assessed using the future lane configurations illustrated in **Figure 14**. The future (2027) total traffic volumes were estimated by adding the site traffic (**Figure 13**) to future (2027) background volumes (**Figure 10**) and the resulting future (2027) total traffic volumes are illustrated in **Figure 15**. The analysis results are provided in **Table 10** and detailed calculations are provided in **Appendix E**.

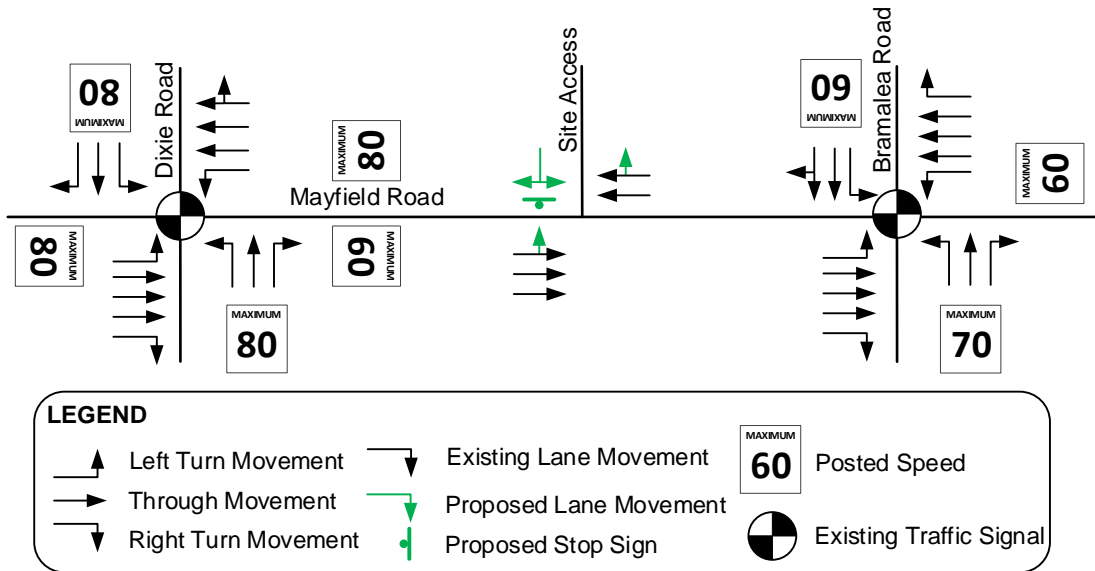

Figure 14: Future Lane Configuration

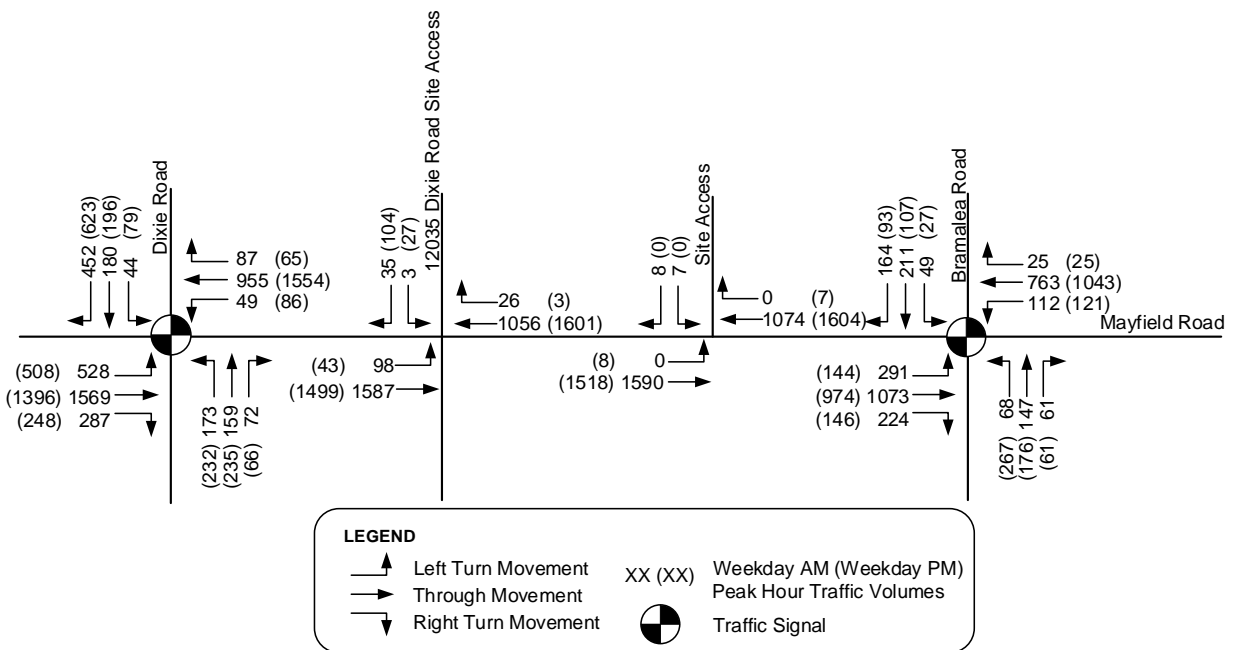

Figure 15: Future (2027) Total Traffic Volumes

Table 10: Future (2027) Total Conditions Intersection Operations

Intersection / Movement	AM Peak Hour				PM Peak Hour				Available Storage (m)
	LOS	Delay (s)	v/c	95 <sup>th</sup> Percentile Queue (m)	LOS	Delay (s)	v/c	95 <sup>th</sup> Percentile Queue (m)	
<b>Bramalea Road at Mayfield Road (Signalized)</b>									
Overall	B	17	0.62	-	C	24	0.61	-	-
EBL	B	13	0.64	37	B	18	0.51	32	180
EBT	A	10	0.37	49	B	17	0.39	72	> 300
EBR	A	8	0.15	9	B	14	0.09	11	110
WBL	C	23	0.50	34	C	31	0.51	47	80
WBT	B	14	0.33	42	C	24	0.48	89	165
WBR	B	12	0.02	< 7	B	18	0.02	<7	100
NBL	D	44	0.47	24	D	54	0.80	84	100
NBT	D	43	0.52	43	C	34	0.32	47	165
NBR	D	36	0.04	< 7	C	31	0.04	<7	165
SBL	C	31	0.20	15	C	26	0.07	9	110
SBTR	C	32	0.31	28	C	27	0.12	15	> 200
<b>Dixie Road at Mayfield Road (Signalized)</b>									
Overall	D	39	<b>1.03</b>	-	E	61	<b>1.27</b>	-	-
EBL	F	101	<b>1.10</b>	<b>206</b>	F	260	<b>1.46</b>	<b>214</b>	170
EBT	B	20	0.61	124	C	26	0.64	107	270
EBR	B	15	0.19	15	B	19	0.16	14	100
WBL	C	28	0.27	14	B	19	0.46	11	150
WBTR	D	37	0.62	92	D	55	<b>1.00</b>	162	> 300
NBL	D	46	0.63	47	D	38	0.62	63	125
NBT	D	37	0.33	38	C	31	0.37	55	> 300
NBR	C	33	0.05	6	C	27	0.05	<7	50
SBL	C	35	0.17	14	C	29	0.24	23	80
SBT	D	37	0.39	43	C	30	0.31	46	> 200
SBR	D	51	0.77	77	E	57	0.89	140	180
<b>Mayfield Road at 12035 Dixie Road Development Access (Signalized)</b>									
Overall	A	8	0.39	-	A	10	0.60	-	-
EBL	A	9	0.24	32	A	10	0.24	8	50
EBT	A	10	0.40	126	A	8	0.42	67	> 200

Intersection / Movement	AM Peak Hour				PM Peak Hour				Available Storage (m)
	LOS	Delay (s)	v/c	95 <sup>th</sup> Percentile Queue (m)	LOS	Delay (s)	v/c	95 <sup>th</sup> Percentile Queue (m)	
EBR	A	-	0.00	< 7	A	-	0.00	< 7	60
WBL	A	-	0.00	< 7	A	-	0.00	< 7	60
WBTR	A	3	0.41	39	A	7	0.62	107	> 200
NBLTR	A	-	0.00	< 7	A	-	0.00	< 7	> 200
SBLTR	E	56	0.06	11	D	54	0.52	37	> 200
<b>Mayfield Road at Site Access (Unsignalized)</b>									
EBLT	A	-	0.37	< 7	A	2	0.36	< 7	> 200
WBTR	A	-	0.42	< 7	A	-	0.63	< 7	> 200
SBLR	<b>F</b>	54	0.17	< 7	A	-	0.00	< 7	> 100

Note: LOS – level of service, v/c – volume to capacity ratio

The analysis results in **Table 10** indicate that all movements at the study intersections are expected to operate with acceptable level of service and residual capacity during the weekday AM and weekday PM peak hours under future (2027) total conditions except the movements identified under future (2027) background conditions and the southbound left-right movement at the proposed site access during the AM peak hour.

### 5.1.1 Proposed Mitigation Measures

Based on the analysis results provided in **Table 10**, no additional mitigation measures are proposed for the Mayfield Road / Dixie Road intersection under future (2027) total conditions other than the mitigation measures proposed under future (2027) background conditions.

The analysis results **Table 10** indicates that the southbound left-right movement at the site access is expected to operate at LOS 'F' during the weekday AM peak hour. It is worth noting that there is a hatched section on Mayfield Road at the site access with an available width of approximately 5.6 metres and a length of approximately 80 metres between the two medians as illustrated in **Figure 16**.

A swept path analysis was conducted to determine if a WB-20 tractor-semitrailer truck's inbound and outbound movements to/from the subject site can be accommodated within the hatched section noted above and the results are provided in **Appendix F**. The swept path analysis results indicate that above-noted design vehicle can be accommodated. Therefore, traffic operations at the Mayfield Road / Site Access intersection were assessed with a two-way-left-turn-lane (TWLTL) on Mayfield Road to allow a two-stage left turn for the outbound traffic from the subject site. The analysis results with mitigation are provided in **Table 11** and detailed calculations are provided in **Appendix E**.

The analysis results in **Table 11** indicate that the southbound left-right movement at the Mayfield Road / Site Access intersection is expected to operate with acceptable level of service and residual capacity during the weekday AM peak hour.

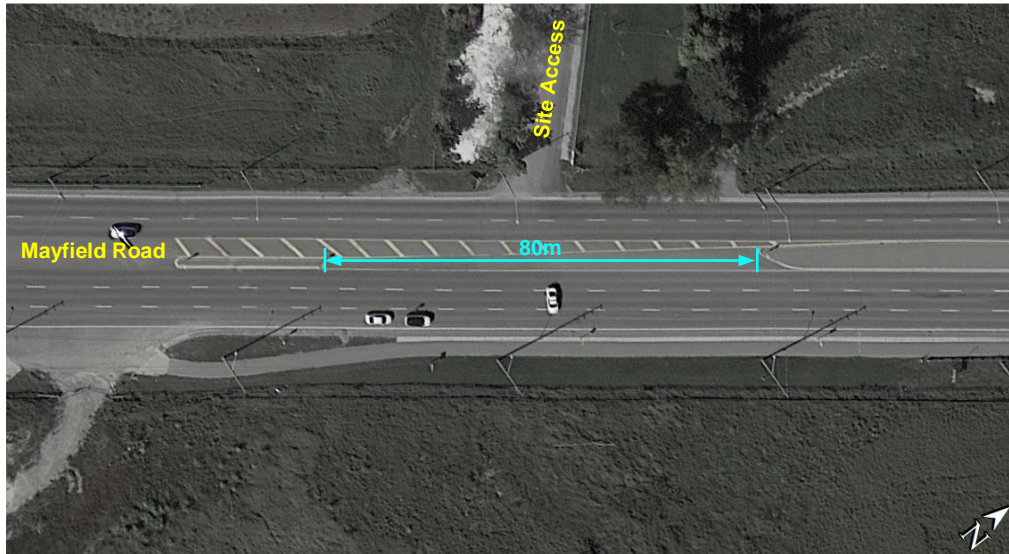

Figure 16: Distance Between Medians

Table 11: Future (2027) Total Conditions Intersection Operations with Mitigation

Intersection / Movement	AM Peak Hour				PM Peak Hour				Available Storage (m)
	LOS	Delay (s)	v/c	95 <sup>th</sup> Percentile Queue (m)	LOS	Delay (s)	v/c	95 <sup>th</sup> Percentile Queue (m)	
<b>Dixie Road at Mayfield Road (Signalized)</b>									
Overall	C	33	0.86	-	D	54	0.99	-	-
EBL	D	40	0.85	179	F	87	<b>1.00</b>	<b>213</b>	215
EBT	B	17	0.55	118	C	21	0.53	106	270
EBR	B	12	0.19	14	B	16	0.16	13	100
WBL	C	28	0.72	9	C	32	0.41	16	150
WBTR	D	42	0.82	94	E	73	<b>1.00</b>	196	> 300
NBL	E	72	0.40	58	F	88	0.91	98	125
NBT	D	45	0.05	46	D	48	0.48	75	> 300
NBR	D	40	0.05	9	D	42	0.05	10	50
SBL	D	43	0.21	17	D	47	0.37	32	80
SBT	D	46	0.46	52	D	47	0.40	63	> 200
SBR	D	46	0.44	39	E	62	0.77	105	180
<b>Mayfield Road at Site Access (Unsignalized)</b>									
EBLT	A	-	0.37	< 7	-	-	-	-	> 200
WBTR	A	-	0.42	< 7	-	-	-	-	> 200
SBLR	C	20	0.06	< 7	-	-	-	-	> 100

Note: LOS – level of service, v/c – volume to capacity ratio

## 5.2 Future (2032) Total Intersection Operations

Future (2032) total intersection operations were assessed using the future lane configurations illustrated in **Figure 14**. The future (2032) total traffic volumes were estimated by adding the site traffic (**Figure 13**) to future (2032) background volumes (**Figure 10**) and the resulting future (2032) total traffic volumes are illustrated in **Figure 15**. The analysis results are provided in **Table 12** and detailed calculations are provided in **Appendix G**.

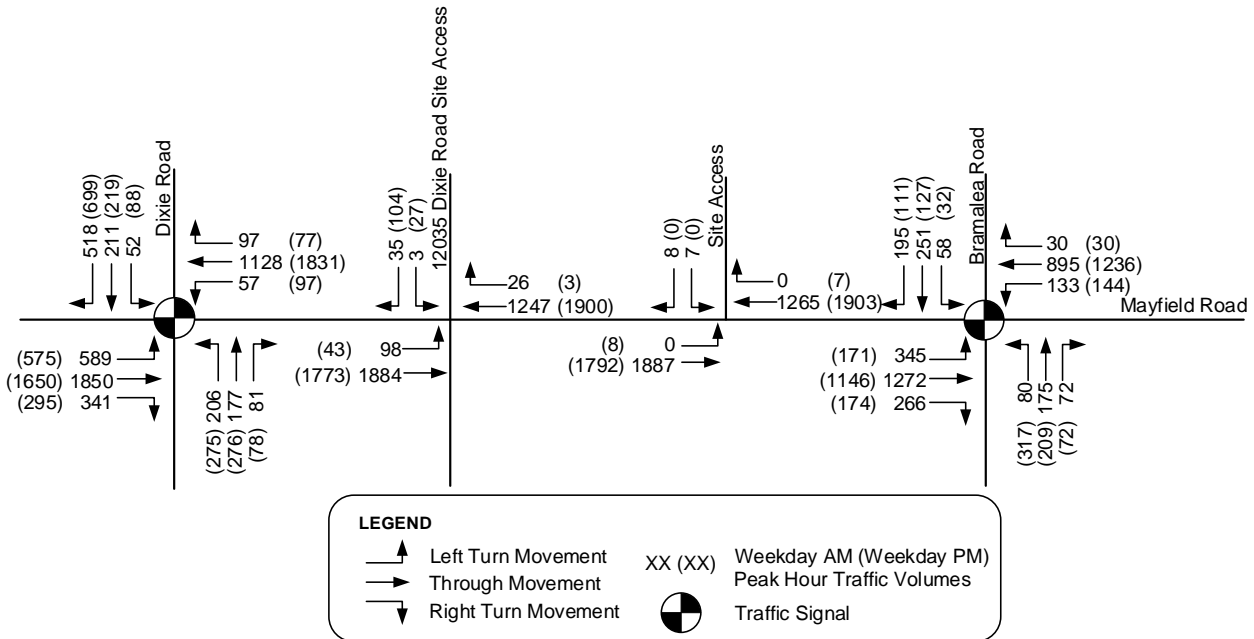

Figure 17: Future (2032) Total Traffic Volumes

Table 12: Future (2032) Total Conditions Intersection Operations

Intersection / Movement	AM Peak Hour				PM Peak Hour				Available Storage (m)
	LOS	Delay (s)	v/c	95 <sup>th</sup> Percentile Queue (m)	LOS	Delay (s)	v/c	95 <sup>th</sup> Percentile Queue (m)	
<b>Bramalea Road at Mayfield Road (Signalized)</b>									
Overall	C	21	0.81	-	C	30	0.82	-	-
EBL	C	33	0.88	71	D	40	0.79	53	180
EBT	B	11	0.45	65	C	21	0.48	88	> 300
EBR	A	9	0.18	11	B	16	0.11	12	110
WBL	D	44	0.75	57	E	59	0.79	73	80
WBT	B	16	0.39	53	C	29	0.60	109	165
WBR	B	12	0.03	< 7	C	21	0.02	< 7	100
NBL	D	46	0.54	28	E	61	0.87	<b>106</b>	100
NBT	D	43	0.56	50	C	33	0.34	56	165

Intersection / Movement	AM Peak Hour				PM Peak Hour				Available Storage (m)
	LOS	Delay (s)	v/c	95 <sup>th</sup> Percentile Queue (m)	LOS	Delay (s)	v/c	95 <sup>th</sup> Percentile Queue (m)	
NBR	D	36	0.05	9	C	29	0.05	8	165
SBL	C	31	0.24	17	C	25	0.08	10	110
SBTR	C	32	0.38	35	C	25	0.14	17	> 200
<b>Dixie Road at Mayfield Road (Signalized)</b>									
Overall	E	66	<b>1.37</b>	-	F	106	<b>1.58</b>	-	-
EBL	F	325	<b>1.62</b>	<b>254</b>	F	492	<b>1.98</b>	<b>247</b>	170
EBT	C	28	0.79	162	D	35	0.83	135	270
EBR	B	18	0.22	16	C	22	0.19	15	100
WBL	C	32	0.41	16	C	30	0.60	13	150
WBTR	D	40	0.73	114	F	118	<b>1.18</b>	210	> 300
NBL	D	43	0.66	58	D	38	0.69	79	125
NBT	C	32	0.31	42	C	28	0.39	64	> 300
NBR	C	29	0.06	8	C	24	0.05	8	50
SBL	C	31	0.17	16	C	27	0.26	25	80
SBT	C	33	0.38	50	C	27	0.31	51	> 200
SBR	D	52	0.83	104	E	67	0.96	177	180
<b>Mayfield Road at 12035 Dixie Road Development Access (Signalized)</b>									
Overall	A	9	0.46	-	B	12	0.70	-	-
EBL	B	11	0.30	25	B	17	0.38	7	50
EBT	B	13	0.47	151	B	11	0.50	91	> 200
EBR	A	-	0.00	< 7	A	-	0.00	< 7	60
WBL	A	-	0.00	< 7	A	-	0.00	< 7	60
WBTR	A	3	0.49	51	A	9	0.73	152	> 200
NBLTR	A	-	0.00	< 7	A	-	0.00	< 7	> 200
SBLTR	E	56	0.06	11	D	54	0.52	37	> 200
<b>Mayfield Road at Site Access (Unsignalized)</b>									
EBLT	A	-	0.44	< 7	A	4	0.42	< 7	> 200
WBTR	A	-	0.50	< 7	A	-	0.75	< 7	> 200
SBLR	F	101	0.29	7	A	-	0.00	< 7	> 100

Note: LOS – level of service, v/c – volume to capacity ratio

The analysis results in **Table 12** indicate that all movements at the study intersections are expected to operate with acceptable level of service and residual capacity during the weekday AM and weekday PM

peak hours under future (2032) total conditions except the movements identified under future (2032) background conditions and the southbound left movement at the proposed site access during the AM peak hour.

### 5.2.1 Proposed Mitigation Measures

Based on the analysis results provided in **Table 12**, no additional mitigation measures are proposed for the Mayfield Road / Dixie Road intersection under future (2032) total conditions other than the mitigation measures proposed under future (2032) background conditions.

The analysis results **Table 12** indicates that the southbound left-right movement at the site access is expected to operate at LOS 'F' during the weekday AM peak hour. As discussed under future (2027) total conditions (**Section 5.1.1**), it is worth noting that there is a hatched section on Mayfield Road at the site access with an available width of approximately 5.6 metres and a length of approximately 80 metres between the two medians (**Figure 16**). Therefore, traffic operations at the Mayfield Road / Site Access intersection were assessed with a two-way-left-turn-lane (TWLTL) on Mayfield Road to allow a two-stage left turn for the outbound traffic from the subject site. The analysis results with mitigation are provided in **Table 13** and detailed calculations are provided in **Appendix G**.

The analysis results in **Table 13** indicate that the southbound left-right movement at the Mayfield Road / Site Access intersection is expected to operate with acceptable level of service and residual capacity during the weekday AM peak hour.

*Table 13: Future (2032) Total Conditions Intersection Operations with Mitigation*

Intersection / Movement	AM Peak Hour				PM Peak Hour				Available Storage (m)
	LOS	Delay (s)	v/c	95 <sup>th</sup> Percentile Queue (m)	LOS	Delay (s)	v/c	95 <sup>th</sup> Percentile Queue (m)	
<b>Dixie Road at Mayfield Road (Signalized)</b>									
Overall	C	34	0.79	-	D	49	0.98	-	-
EBL	C	32	0.72	66	E	70	0.93	104	170
EBT	C	22	0.66	152	C	28	0.68	141	270
EBR	B	15	0.22	14	B	20	0.19	14	100
WBL	C	27	0.41	12	C	28	0.52	19	150
WBTR	D	36	0.66	134	E	55	0.96	218	> 300
NBL	F	92	0.91	90	F	90	0.95	122	125
NBT	D	47	0.38	58	D	44	0.49	86	> 300
NBR	D	42	0.06	10	D	37	0.05	11	50
SBL	D	45	0.22	22	D	43	0.37	35	80
SBT	D	49	0.46	68	D	42	0.38	68	> 200
SBR	D	47	0.36	30	E	71	0.99	251	255
<b>Mayfield Road at Site Access (Unsignalized)</b>									
EBLT	A	-	0.44	< 7	-	-	-	-	> 200

Intersection / Movement	AM Peak Hour				PM Peak Hour				Available Storage (m)
	LOS	Delay (s)	v/c	95 <sup>th</sup> Percentile Queue (m)	LOS	Delay (s)	v/c	95 <sup>th</sup> Percentile Queue (m)	
WBTR	A	-	0.50	< 7	-	-	-	-	> 200
SBLR	C	24	0.07	< 7	-	-	-	-	> 100

Note: LOS – level of service, v/c – volume to capacity ratio

## 6.0 Site Plan and Access Review

### 6.1 Site Plan and Access Review

The proposed development, located north of Mayfield and approximately 360 metres west of Bramalea Road, will consist of 15 transport truck/trailer parking facility. The existing driveway will remain which has a minimum width of 8.0 metres (**Figure 12**). The access to/from the site will be provided via the existing full-move site access fronting on Mayfield Road. Based on the “*Region of Peel’s Road Characterization Study*”, Mayfield Road is classified as an “Industrial Connector” with a minimum full to full access spacing of 450 metres. However, it is worth noting that the site access is an existing full-move access with relatively similar operations including similar design vehicles (i.e., WB-20 Tractor-Semitrailer Truck). Moreover, as discussed in **Section 5.1.1**, it is noted that there is a hatched section on Mayfield Road at the site access with an available width of approximately 5.6 metres and a length of approximately 80 metres between the two medians (**Figure 16**). Not only this space can be used as a left turn storage for the inbound truck traffic, it can also allow a two-stage left turn for the outbound truck traffic resulting in improved operations at the Mayfield Road / Site Access intersection and an acceptable level of service under future total conditions summarized in **Table 11** and **Table 13**.

### 6.2 Sightline Review

Mayfield Road is relatively level in the vicinity of the site access and there are no apparent horizontal or vertical curves that would impact sightlines. It is worth noting that the site access is an existing full-move access. Therefore, there are no potential concerns regarding sightlines with the site access location. It is suggested that proper care should be taken to ensure no obstructions are placed in the sight triangles of the proposed site access.

### 6.3 Site Circulation

A swept path analysis was undertaken for the site plan to assess the site circulation using the following design vehicle and the results are provided in **Appendix H**:

- WB-20 Tractor-Semitrailer Truck (TAC Geometric Design Guide for Canadian Roads, 1999)

The swept path analysis results in **Appendix H** indicate that the WB-20 Tractor-Semitrailer Truck can be accommodated at all designated parking spaces within the site.

## 7.0 Parking Review

A total of 15 transport truck/trailer parking spaces will be provided on site. The proposed parking spaces will have a width of 3.5 metres and a length of 18.0 metres with an aisle width of 20.0 metres which can the design vehicle’s movements. Moreover, trailers can be accommodated and stored within the designated parking spaces.

## 8.0 Conclusions

Based on the analysis results, the following conclusions can be made:

### Existing Conditions

- The analysis results indicate that all movements at the study intersections are operating with acceptable level of service and residual capacity during the weekday AM and weekday PM peak hours under existing conditions.

### Future Background Conditions

- The analysis results indicate that all movements at the study intersections are expected to operate with acceptable level of service and residual capacity during the weekday AM, weekday PM, and Friday peak hours under both future (2027) background and future (2032) background conditions except for the following movements at the Dixie Road / Mayfield Road intersection:
  - Eastbound left movement during the weekday AM and PM peak hours
  - Westbound through-right movement during the PM peak hour
- The following mitigation measures are proposed at the intersection of Dixie Road / Mayfield Road under future (2027) background conditions:
  - Increase the cycle length from 120 seconds to 130 seconds and 150 seconds during the weekday AM and weekday PM peak hours, respectively.
  - Increase the storage for the eastbound left movement from 170 metres to 215 metres.
- The following mitigation measures are proposed at the intersection of Dixie Road / Mayfield Road under future (2032) background conditions:
  - Increase the cycle length from 130 seconds to 150 seconds during the weekday AM peak hour.
  - Provide an additional left turn lane in the eastbound direction and widen the north leg to accommodate two receiving lanes.
  - Provide a protected-permissive southbound right phase overlapped with the eastbound left phase.
  - Increase the storage for the southbound right movement from 180 metres to 255 metres.

### Site Traffic Trip Generation

- The site is expected to generate a maximum of 15 outbound truck trips and 15 inbound truck trips during the weekday AM and weekday PM peak hours, respectively.

### Future Total Conditions

- The analysis results indicate that all movements at the study intersections are expected to operate with acceptable level of service and residual capacity during the weekday AM, weekday PM, and Friday peak hours under both future (2027) total and future (2032) total conditions except for the movements identified at the Dixie Road / Mayfield Road intersection under future background conditions, and the southbound left-right movement at the proposed site access during the AM peak hour.
- No additional mitigation measures are proposed for the Mayfield Road / Dixie Road intersection under future (2027) total conditions other than the mitigation measures proposed under future (2027) background conditions.

- Similarly, no additional mitigation measures are proposed for the Mayfield Road / Dixie Road intersection under future (2032) total conditions other than the mitigation measures proposed under future (2032) background conditions.
- It is worth noting that there is a hatched section on Mayfield Road at the site access with an available width of approximately 5.6 metres and a length of approximately 80 metres between the two medians (**Figure 16**). A swept path analysis was conducted using a WB-20 tractor-semitrailer truck and the analysis results indicate that the design vehicle's inbound and outbound movements can be accommodated within the hatched section as a storage. Therefore, traffic operations at the Mayfield Road / Site Access intersection were assessed with a two-way-left-turn-lane (TWLTL) on Mayfield Road to allow a two-stage left turn for the outbound traffic from the subject site. The analysis results indicate that the southbound left-right movement at the Mayfield Road / Site Access intersection is expected to operate with acceptable level of service and residual capacity during the weekday AM peak hour under future total conditions.

### Site Plan and Access Review

- The access to/from the site will be provided via the existing full-move site access fronting on Mayfield Road. Based on the "Region of Peel's Road Characterization Study", Mayfield Road is classified as an "Industrial Connector" with a minimum full to full access spacing of 450 metres. However, it is worth noting that the site access is an existing full-move access with relatively similar operations including similar design vehicles (i.e., WB-20 Tractor-Semitrailer Truck). Moreover, it is noted that the hatched section on Mayfield Road, discussed above, not only can be used as a left turn storage for the inbound truck traffic, it can also allow a two-stage left turn for the outbound truck traffic resulting in improved operations and an acceptable level of service at the Mayfield Road / Site Access intersection.
- The swept path analysis results indicate that the WB-20 Tractor-Semitrailer Truck can be accommodated at all designated parking spaces within the site.

### Parking Supply

- The proposed parking spaces will have a width of 3.5 metres and a length of 18.0 metres with an aisle width of 20.0 metres which can the design vehicle's movements. Moreover, trailers can be accommodated and stored within the designated parking spaces.

## **Appendix A**

### Existing Turning Movement Count Data



**Turning Movement Count (11 . MAYFIELD RD & BRAMALEA RD) CustID: 01411004 MioID: 369881**

Start Time	Southbound BRAMALEA ROAD						Westbound MAYFIELD RD						Northbound BRAMALEA ROAD						Eastbound MAYFIELD RD						Int. Total (15 min)	Int. Total (1 hr)
	Left	Thru	Right	U-Turn	Peds	Approach Total	Left	Thru	Right	U-Turn	Peds	Approach Total	Left	Thru	Right	U-Turn	Peds	Approach Total	Left	Thru	Right	U-Turn	Peds	Approach Total		
07:00:00	3	12	7	0	0	22	12	140	2	0	0	154	6	8	13	0	0	27	9	220	54	0	0	283	486	
07:15:00	7	23	7	0	0	37	16	152	1	0	1	169	6	8	11	0	0	25	19	208	49	0	0	276	507	
07:30:00	8	41	29	0	0	78	14	130	5	0	5	149	15	34	12	0	1	61	59	254	47	0	0	360	648	
07:45:00	13	51	50	0	0	114	26	168	13	0	2	207	17	50	16	0	1	83	117	234	54	0	0	405	809	2450
08:00:00	13	63	52	0	0	128	38	145	2	1	1	186	19	32	12	0	0	63	48	198	37	0	0	283	660	2624
08:15:00	5	28	11	0	0	44	19	110	4	0	0	133	18	15	14	0	0	47	19	178	37	0	0	234	458	2575
08:30:00	3	18	4	0	0	25	23	161	6	0	1	190	20	16	13	0	0	49	19	187	30	0	0	236	500	2427
08:45:00	3	15	10	0	0	28	11	115	7	1	0	134	21	16	14	0	0	51	34	148	29	0	1	211	424	2042
***BREAK***																										
11:00:00	2	8	7	0	0	17	17	110	2	0	1	129	19	12	6	0	0	37	5	81	17	0	0	103	286	
11:15:00	4	13	6	0	0	23	11	102	4	0	3	117	22	16	6	0	0	44	11	112	22	0	0	145	329	
11:30:00	4	13	6	0	0	23	9	96	5	1	0	111	24	18	7	0	1	49	12	95	21	0	0	128	311	
11:45:00	5	11	5	0	4	21	18	105	5	0	4	128	24	16	7	0	0	47	8	107	24	0	0	139	335	1261
12:00:00	3	22	10	0	0	35	14	87	3	0	6	104	18	8	8	0	0	34	14	117	27	0	0	158	331	1306
12:15:00	4	16	11	0	0	31	15	112	1	0	2	128	20	15	3	0	0	38	9	120	25	0	0	154	351	1328
12:30:00	1	6	6	0	0	13	11	115	2	0	0	128	18	11	5	0	0	34	8	98	27	0	0	133	308	1325
12:45:00	3	10	6	0	0	19	16	84	2	0	1	102	27	14	7	0	0	48	9	116	15	0	1	140	309	1299
13:00:00	3	7	3	0	0	13	12	99	0	0	4	111	32	13	6	0	0	51	8	112	32	0	0	152	327	1295
13:15:00	2	16	3	0	0	21	17	111	2	0	1	130	31	15	4	0	0	50	9	122	22	0	0	153	354	1298
13:30:00	4	12	13	0	0	29	14	101	5	0	0	120	25	12	10	0	0	47	10	129	28	0	0	167	363	1353
13:45:00	8	11	7	0	0	26	16	113	5	1	0	135	36	12	8	0	0	56	8	135	26	0	0	169	386	1430
***BREAK***																										
15:00:00	2	18	20	0	0	40	19	174	6	0	0	199	47	27	2	0	0	76	16	165	29	0	0	210	525	
15:15:00	12	10	16	0	0	38	27	179	12	3	0	221	48	40	3	0	0	91	28	146	17	0	0	191	541	
15:30:00	16	28	35	0	0	79	20	139	4	0	1	163	51	44	11	0	0	106	15	166	34	0	0	215	563	
15:45:00	11	24	18	0	2	53	27	190	3	0	0	220	41	36	5	0	0	82	37	170	32	0	0	239	594	2223
16:00:00	6	25	24	0	0	55	21	169	5	1	3	196	54	40	15	0	0	109	23	190	27	0	0	240	600	2298
16:15:00	11	17	25	0	0	53	34	190	4	0	0	228	72	32	18	0	0	122	24	175	30	0	0	229	632	2389
16:30:00	4	31	25	0	0	60	34	199	8	0	0	241	54	44	11	0	0	109	39	199	28	0	0	266	676	2502
16:45:00	5	15	21	0	0	41	24	211	5	0	4	240	51	32	13	0	0	96	25	194	31	0	0	250	627	2535
17:00:00	7	22	21	0	0	50	19	210	5	0	2	234	61	31	16	0	0	108	23	179	33	0	0	235	627	2562
17:15:00	7	22	10	0	1	39	25	248	3	1	0	277	57	41	11	0	0	109	34	199	31	0	0	264	689	2619



Turning Movement Count  
 Location Name: MAYFIELD RD & BRAMALEA RD  
 Date: Tue, Nov 29, 2016 Deployment Lead: Chris Koukaras

Peel Region  
 10 Peel Centre Drive  
 Suite B - 4th Floor  
 Brampton ON, Canada, L6T 4B9

17:30:00	6	23	11	0	0	40	22	203	2	0	0	227	69	37	17	0	0	123	17	170	26	0	0	213	603	2546
17:45:00	5	15	14	0	0	34	21	194	3	1	0	219	66	21	12	0	0	99	12	145	31	0	0	188	540	2459
<b>Grand Total</b>	<b>190</b>	<b>646</b>	<b>493</b>	<b>0</b>	<b>7</b>	<b>1329</b>	<b>622</b>	<b>4662</b>	<b>136</b>	<b>10</b>	<b>42</b>	<b>5430</b>	<b>1089</b>	<b>766</b>	<b>316</b>	<b>0</b>	<b>3</b>	<b>2171</b>	<b>728</b>	<b>5069</b>	<b>972</b>	<b>0</b>	<b>2</b>	<b>6769</b>	<b>15699</b>	<b>-</b>
<b>Approach%</b>	14.3%	48.6%	37.1%	0%	-	-	11.5%	85.9%	2.5%	0.2%	-	-	50.2%	35.3%	14.6%	0%	-	-	10.8%	74.9%	14.4%	0%	-	-	-	
<b>Totals %</b>	1.2%	4.1%	3.1%	0%	8.5%	4%	29.7%	0.9%	0.1%	34.6%	6.9%	4.9%	2%	0%	13.8%	4.6%	32.3%	6.2%	0%	43.1%	-	-	-	-	-	
<b>Heavy</b>	13	13	22	0	-	28	761	21	0	-	22	26	15	0	-	17	756	34	0	-	-	-	-	-	-	
<b>Heavy %</b>	6.8%	2%	4.5%	0%	-	4.5%	16.3%	15.4%	0%	-	2%	3.4%	4.7%	0%	-	2.3%	14.9%	3.5%	0%	-	-	-	-	-	-	
<b>Bicycles</b>	0	0	0	0	-	0	0	0	0	-	0	0	0	0	-	0	1	0	0	-	-	-	-	-	-	
<b>Bicycle %</b>	0%	0%	0%	0%	-	0%	0%	0%	0%	-	0%	0%	0%	0%	-	0%	0%	0%	0%	-	-	-	-	-	-	



**Peak Hour: 07:15 AM - 08:15 AM Weather:**

Start Time	Southbound BRAMALEA ROAD						Westbound MAYFIELD RD						Northbound BRAMALEA ROAD						Eastbound MAYFIELD RD						Int. Total (15 min)
	Left	Thru	Right	U-Turn	Peds	Approach Total	Left	Thru	Right	U-Turn	Peds	Approach Total	Left	Thru	Right	U-Turn	Peds	Approach Total	Left	Thru	Right	U-Turn	Peds	Approach Total	
07:15:00	7	23	7	0	0	37	16	152	1	0	1	169	6	8	11	0	0	25	19	208	49	0	0	276	507
07:30:00	8	41	29	0	0	78	14	130	5	0	5	149	15	34	12	0	1	61	59	254	47	0	0	360	648
07:45:00	13	51	50	0	0	114	26	168	13	0	2	207	17	50	16	0	1	83	117	234	54	0	0	405	809
08:00:00	13	63	52	0	0	128	38	145	2	1	1	186	19	32	12	0	0	63	48	198	37	0	0	283	660
<b>Grand Total</b>	<b>41</b>	<b>178</b>	<b>138</b>	<b>0</b>	<b>0</b>	<b>357</b>	<b>94</b>	<b>595</b>	<b>21</b>	<b>1</b>	<b>9</b>	<b>711</b>	<b>57</b>	<b>124</b>	<b>51</b>	<b>0</b>	<b>2</b>	<b>232</b>	<b>243</b>	<b>894</b>	<b>187</b>	<b>0</b>	<b>0</b>	<b>1324</b>	<b>2624</b>
<b>Approach%</b>	11.5%	49.9%	38.7%	0%	-	-	13.2%	83.7%	3%	0.1%	-	-	24.6%	53.4%	22%	0%	-	-	18.4%	67.5%	14.1%	0%	-	-	-
<b>Totals %</b>	1.6%	6.8%	5.3%	0%	-	13.6%	3.6%	22.7%	0.8%	0%	-	27.1%	2.2%	4.7%	1.9%	0%	-	8.8%	9.3%	34.1%	7.1%	0%	-	50.5%	-
<b>PHF</b>	0.79	0.71	0.66	0	-	0.7	0.62	0.89	0.4	0.25	-	0.86	0.75	0.62	0.8	0	-	0.7	0.52	0.88	0.87	0	-	0.82	-
<b>Heavy</b>	5	2	3	0	-	10	10	108	8	0	-	126	3	5	5	0	-	13	1	108	7	0	-	116	-
<b>Heavy %</b>	12.2%	1.1%	2.2%	0%	-	2.8%	10.6%	18.2%	38.1%	0%	-	17.7%	5.3%	4%	9.8%	0%	-	5.6%	0.4%	12.1%	3.7%	0%	-	8.8%	-
<b>Lights</b>	36	176	135	0	-	347	84	487	13	1	-	585	54	119	46	0	-	219	242	786	180	0	-	1208	-
<b>Lights %</b>	87.8%	98.9%	97.8%	0%	-	97.2%	89.4%	81.8%	61.9%	100%	-	82.3%	94.7%	96%	90.2%	0%	-	94.4%	99.6%	87.9%	96.3%	0%	-	91.2%	-
<b>Single-Unit Trucks</b>	0	1	0	0	-	1	0	36	0	0	-	36	2	0	1	0	-	3	1	42	2	0	-	45	-
<b>Single-Unit Trucks %</b>	0%	0.6%	0%	0%	-	0.3%	0%	6.1%	0%	0%	-	5.1%	3.5%	0%	2%	0%	-	1.3%	0.4%	4.7%	1.1%	0%	-	3.4%	-
<b>Buses</b>	5	1	3	0	-	9	10	29	8	0	-	47	1	5	4	0	-	10	0	33	4	0	-	37	-
<b>Buses %</b>	12.2%	0.6%	2.2%	0%	-	2.5%	10.6%	4.9%	38.1%	0%	-	6.6%	1.8%	4%	7.8%	0%	-	4.3%	0%	3.7%	2.1%	0%	-	2.8%	-
<b>Articulated Trucks</b>	0	0	0	0	-	0	0	43	0	0	-	43	0	0	0	0	-	0	0	33	1	0	-	34	-
<b>Articulated Trucks %</b>	0%	0%	0%	0%	-	0%	0%	7.2%	0%	0%	-	6%	0%	0%	0%	0%	-	0%	0%	3.7%	0.5%	0%	-	2.6%	-
<b>Pedestrians</b>	-	-	-	-	0	-	-	-	-	9	-	-	-	-	-	2	-	-	-	-	-	-	0	-	-
<b>Pedestrians%</b>	-	-	-	-	0%	-	-	-	-	81.8%	-	-	-	-	18.2%	-	-	-	-	-	-	-	0%	-	-
<b>Bicycles on Crosswalk</b>	-	-	-	-	0	-	-	-	-	0	-	-	-	-	0	-	-	-	-	-	-	-	0	-	-
<b>Bicycles on Crosswalk%</b>	-	-	-	-	0%	-	-	-	-	0%	-	-	-	-	0%	-	-	-	-	-	-	-	0%	-	-
<b>Bicycles on Road</b>	0	0	0	0	0	-	0	0	0	0	-	-	0	0	0	0	-	-	0	0	0	0	0	-	-
<b>Bicycles on Road%</b>	-	-	-	-	0%	-	-	-	-	0%	-	-	-	-	0%	-	-	-	-	-	-	-	0%	-	-



**Peak Hour: 01:00 PM - 02:00 PM Weather:**

Start Time	Southbound BRAMALEA ROAD						Westbound MAYFIELD RD						Northbound BRAMALEA ROAD						Eastbound MAYFIELD RD						Int. Total (15 min)
	Left	Thru	Right	U-Turn	Peds	Approach Total	Left	Thru	Right	U-Turn	Peds	Approach Total	Left	Thru	Right	U-Turn	Peds	Approach Total	Left	Thru	Right	U-Turn	Peds	Approach Total	
13:00:00	3	7	3	0	0	13	12	99	0	0	4	111	32	13	6	0	0	51	8	112	32	0	0	152	327
13:15:00	2	16	3	0	0	21	17	111	2	0	1	130	31	15	4	0	0	50	9	122	22	0	0	153	354
13:30:00	4	12	13	0	0	29	14	101	5	0	0	120	25	12	10	0	0	47	10	129	28	0	0	167	363
13:45:00	8	11	7	0	0	26	16	113	5	1	0	135	36	12	8	0	0	56	8	135	26	0	0	169	386
<b>Grand Total</b>	17	46	26	0	0	89	59	424	12	1	5	496	124	52	28	0	0	204	35	498	108	0	0	641	1430
<b>Approach%</b>	19.1%	51.7%	29.2%	0%	-	-	11.9%	85.5%	2.4%	0.2%	-	60.8%	25.5%	13.7%	0%	-	5.5%	77.7%	16.8%	0%	-	-	-	-	
<b>Totals %</b>	1.2%	3.2%	1.8%	0%	6.2%	4.1%	29.7%	0.8%	0.1%	34.7%	8.7%	3.6%	2%	0%	14.3%	2.4%	34.8%	7.6%	0%	44.8%	-	-	-	-	
<b>PHF</b>	0.53	0.72	0.5	0	0.77	0.87	0.94	0.6	0.25	0.92	0.86	0.87	0.7	0	0.91	0.88	0.92	0.84	0	0.95	-	-	-	-	
<b>Heavy</b>	2	3	2	0	7	3	97	1	0	101	2	2	2	0	6	1	93	5	0	99	-	-	-	-	
<b>Heavy %</b>	11.8%	6.5%	7.7%	0%	7.9%	5.1%	22.9%	8.3%	0%	20.4%	1.6%	3.8%	7.1%	0%	2.9%	2.9%	18.7%	4.6%	0%	15.4%	-	-	-	-	
<b>Lights</b>	15	43	24	0	82	56	327	11	1	395	122	50	26	0	198	34	405	103	0	542	-	-	-	-	
<b>Lights %</b>	88.2%	93.5%	92.3%	0%	92.1%	94.9%	77.1%	91.7%	100%	79.6%	98.4%	96.2%	92.9%	0%	97.1%	97.1%	81.3%	95.4%	0%	84.6%	-	-	-	-	
<b>Single-Unit Trucks</b>	0	0	1	0	1	2	44	0	0	46	2	0	2	0	4	0	42	4	0	46	-	-	-	-	
<b>Single-Unit Trucks %</b>	0%	0%	3.8%	0%	1.1%	3.4%	10.4%	0%	0%	9.3%	1.6%	0%	7.1%	0%	2%	0%	8.4%	3.7%	0%	7.2%	-	-	-	-	
<b>Buses</b>	2	3	0	0	5	1	16	1	0	18	0	2	0	0	2	0	6	1	0	7	-	-	-	-	
<b>Buses %</b>	11.8%	6.5%	0%	0%	5.6%	1.7%	3.8%	8.3%	0%	3.6%	0%	3.8%	0%	0%	1%	0%	1.2%	0.9%	0%	1.1%	-	-	-	-	
<b>Articulated Trucks</b>	0	0	1	0	1	0	37	0	0	37	0	0	0	0	0	1	45	0	0	46	-	-	-	-	
<b>Articulated Trucks %</b>	0%	0%	3.8%	0%	1.1%	0%	8.7%	0%	0%	7.5%	0%	0%	0%	0%	0%	2.9%	9%	0%	0%	7.2%	-	-	-	-	
<b>Pedestrians</b>	-	-	-	-	0	-	-	-	-	5	-	-	-	-	0	-	-	-	-	0	-	-	-	-	
<b>Pedestrians%</b>	-	-	-	-	0%	-	-	-	-	100%	-	-	-	-	0%	-	-	-	-	0%	-	-	-	-	
<b>Bicycles on Crosswalk</b>	-	-	-	-	0	-	-	-	-	0	-	-	-	-	0	-	-	-	-	0	-	-	-	-	
<b>Bicycles on Crosswalk%</b>	-	-	-	-	0%	-	-	-	-	0%	-	-	-	-	0%	-	-	-	-	0%	-	-	-	-	
<b>Bicycles on Road</b>	0	0	0	0	0	-	0	0	0	0	-	0	0	0	0	0	0	0	0	0	-	-	-	-	
<b>Bicycles on Road%</b>	-	-	-	-	0%	-	-	-	-	0%	-	-	-	-	0%	-	-	-	-	0%	-	-	-	-	



**Peak Hour: 04:30 PM - 05:30 PM Weather:**

Start Time	Southbound BRAMALEA ROAD						Westbound MAYFIELD RD						Northbound BRAMALEA ROAD						Eastbound MAYFIELD RD						Int. Total (15 min)
	Left	Thru	Right	U-Turn	Peds	Approach Total	Left	Thru	Right	U-Turn	Peds	Approach Total	Left	Thru	Right	U-Turn	Peds	Approach Total	Left	Thru	Right	U-Turn	Peds	Approach Total	
16:30:00	4	31	25	0	0	60	34	199	8	0	0	241	54	44	11	0	0	109	39	199	28	0	0	266	676
16:45:00	5	15	21	0	0	41	24	211	5	0	4	240	51	32	13	0	0	96	25	194	31	0	0	250	627
17:00:00	7	22	21	0	0	50	19	210	5	0	2	234	61	31	16	0	0	108	23	179	33	0	0	235	627
17:15:00	7	22	10	0	1	39	25	248	3	1	0	277	57	41	11	0	0	109	34	199	31	0	0	264	689
<b>Grand Total</b>	<b>23</b>	<b>90</b>	<b>77</b>	<b>0</b>	<b>1</b>	<b>190</b>	<b>102</b>	<b>868</b>	<b>21</b>	<b>1</b>	<b>6</b>	<b>992</b>	<b>223</b>	<b>148</b>	<b>51</b>	<b>0</b>	<b>0</b>	<b>422</b>	<b>121</b>	<b>771</b>	<b>123</b>	<b>0</b>	<b>0</b>	<b>1015</b>	<b>2619</b>
<b>Approach%</b>	12.1%	47.4%	40.5%	0%	-	-	10.3%	87.5%	2.1%	0.1%	-	-	52.8%	35.1%	12.1%	0%	-	-	11.9%	76%	12.1%	0%	-	-	-
<b>Totals %</b>	0.9%	3.4%	2.9%	0%	7.3%	7.3%	3.9%	33.1%	0.8%	0%	37.9%	37.9%	8.5%	5.7%	1.9%	0%	16.1%	16.1%	4.6%	29.4%	4.7%	0%	38.8%	38.8%	-
<b>PHF</b>	0.82	0.73	0.77	0	0.79	0.79	0.75	0.88	0.66	0.25	0.9	0.9	0.91	0.84	0.8	0	0.97	0.97	0.78	0.97	0.93	0	0.95	0.95	-
<b>Heavy</b>	0	1	4	0	5	5	0	72	1	0	73	73	2	0	0	0	2	2	1	93	2	0	96	96	-
<b>Heavy %</b>	0%	1.1%	5.2%	0%	2.6%	2.6%	0%	8.3%	4.8%	0%	7.4%	7.4%	0.9%	0%	0%	0%	0.5%	0.5%	0.8%	12.1%	1.6%	0%	9.5%	9.5%	-
<b>Lights</b>	23	89	73	0	185	185	102	796	20	1	919	919	221	148	51	0	420	420	120	678	121	0	919	919	-
<b>Lights %</b>	100%	98.9%	94.8%	0%	97.4%	97.4%	100%	91.7%	95.2%	100%	92.6%	92.6%	99.1%	100%	100%	0%	99.5%	99.5%	99.2%	87.9%	98.4%	0%	90.5%	90.5%	-
<b>Single-Unit Trucks</b>	0	0	3	0	3	3	0	36	0	0	36	36	1	0	0	0	1	1	1	29	1	0	31	31	-
<b>Single-Unit Trucks %</b>	0%	0%	3.9%	0%	1.6%	1.6%	0%	4.1%	0%	0%	3.6%	3.6%	0.4%	0%	0%	0%	0.2%	0.2%	0.8%	3.8%	0.8%	0%	3.1%	3.1%	-
<b>Buses</b>	0	1	1	0	2	2	0	7	1	0	8	8	1	0	0	0	1	1	0	14	1	0	15	15	-
<b>Buses %</b>	0%	1.1%	1.3%	0%	1.1%	1.1%	0%	0.8%	4.8%	0%	0.8%	0.8%	0.4%	0%	0%	0%	0.2%	0.2%	0%	1.8%	0.8%	0%	1.5%	1.5%	-
<b>Articulated Trucks</b>	0	0	0	0	0	0	0	29	0	0	29	29	0	0	0	0	0	0	0	50	0	0	50	50	-
<b>Articulated Trucks %</b>	0%	0%	0%	0%	0%	0%	0%	3.3%	0%	0%	2.9%	2.9%	0%	0%	0%	0%	0%	0%	0%	6.5%	0%	0%	4.9%	4.9%	-
<b>Pedestrians</b>	-	-	-	-	1	-	-	-	-	-	6	-	-	-	-	-	0	-	-	-	-	-	0	-	-
<b>Pedestrians%</b>	-	-	-	-	14.3%	-	-	-	-	-	85.7%	-	-	-	-	-	0%	-	-	-	-	-	0%	-	-
<b>Bicycles on Crosswalk</b>	-	-	-	-	0	-	-	-	-	-	0	-	-	-	-	-	0	-	-	-	-	-	0	-	-
<b>Bicycles on Crosswalk%</b>	-	-	-	-	0%	-	-	-	-	-	0%	-	-	-	-	-	0%	-	-	-	-	-	0%	-	-
<b>Bicycles on Road</b>	0	0	0	0	0	-	0	0	0	0	0	-	0	0	0	0	-	-	0	0	0	0	0	-	-
<b>Bicycles on Road%</b>	-	-	-	-	0%	-	-	-	-	-	0%	-	-	-	-	-	0%	-	-	-	-	-	0%	-	-

Peak Hour: 07:15 AM - 08:15 AM Weather:



Peak Hour: 01:00 PM - 02:00 PM Weather:

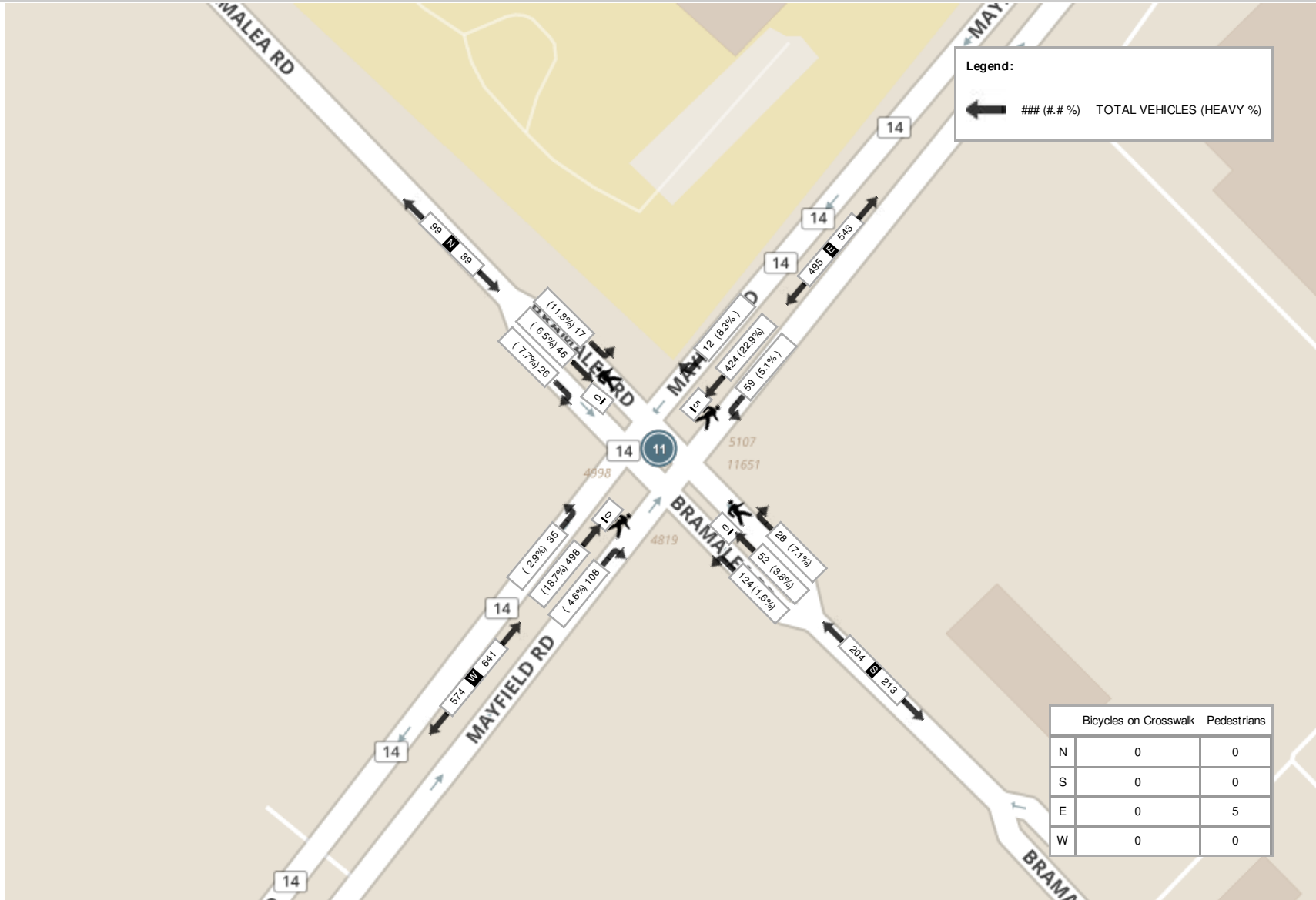

Peak Hour: 04:30 PM - 05:30 PM Weather:

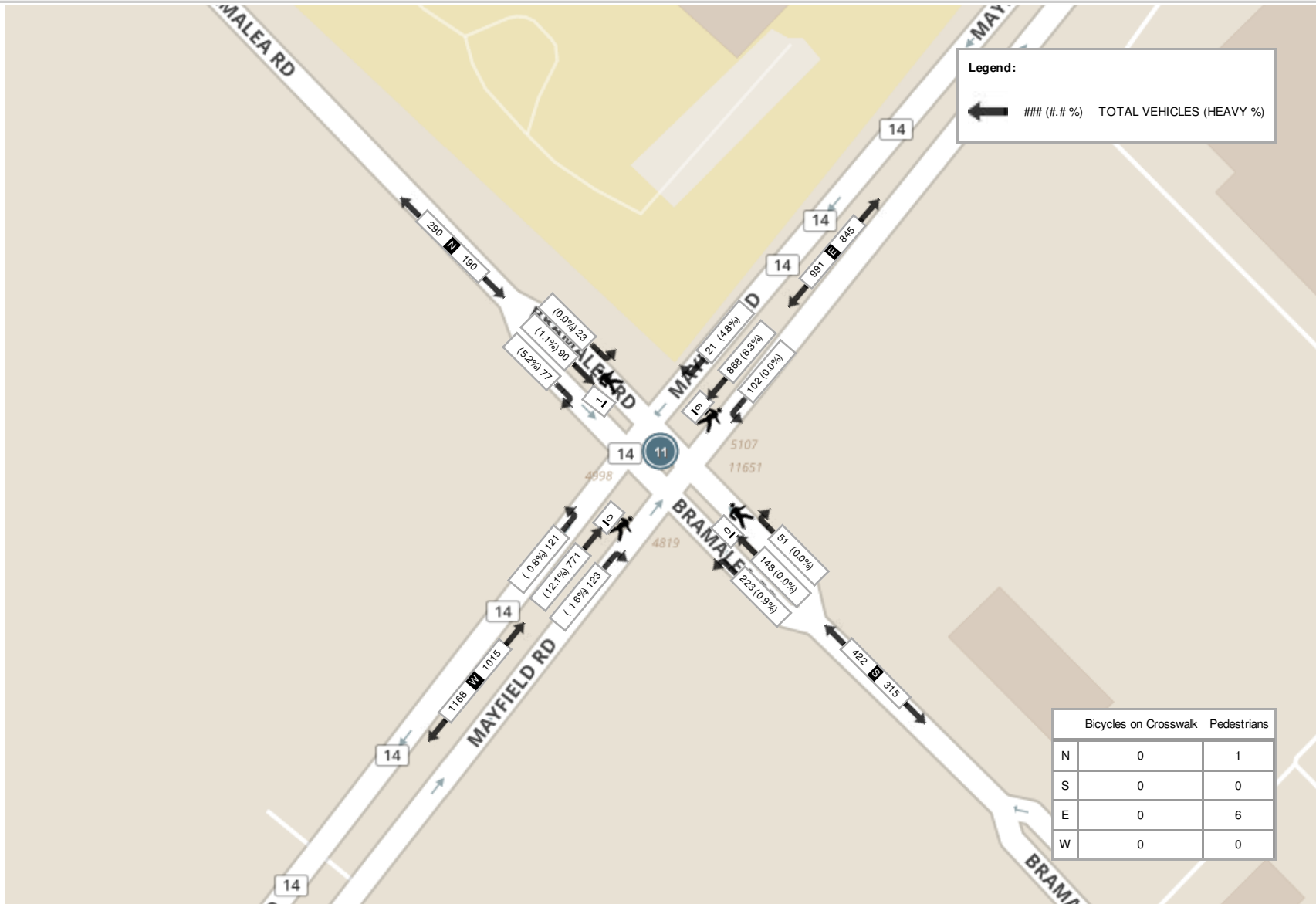



Turning Movement Count (62 . DIXIE RD & MAYFIELD RD) CustID: 00427526 MioID:

Start Time	Southbound DIXIE RD						Westbound MAYFIELD RD						Northbound DIXIE RD						Eastbound MAYFIELD RD						Int. Total (15 min)	
	Left	Thru	Right	UTurn	Peds	Approach Total	Left	Thru	Right	UTurn	Peds	Approach Total	Left	Thru	Right	UTurn	Peds	Approach Total	Left	Thru	Right	UTurn	Peds	Approach Total		
07:00:00	6	32	74	0	0	112	9	148	8	0	0	165	14	10	4	0	0	28	55	253	42	0	0	350	655	
07:15:00	6	37	75	0	0	118	10	147	3	0	0	160	24	12	2	0	1	38	72	270	47	0	0	389	705	
07:30:00	11	53	69	0	0	133	12	146	4	0	0	162	36	16	3	0	1	55	79	370	58	0	2	507	857	
07:45:00	7	44	58	0	0	109	24	221	13	0	0	258	25	14	7	0	0	46	70	429	65	1	0	565	978	
Hourly	30	166	276	0	0	472	55	662	28	0	0	745	99	52	16	0	2	167	276	1322	212	1	2	1811	3195	
08:00:00	9	42	79	0	0	130	10	227	6	0	0	243	40	18	13	0	0	71	62	351	60	0	0	473	917	
08:15:00	11	32	77	0	0	120	8	200	7	0	0	215	28	14	9	0	0	51	62	320	55	0	0	437	823	
08:30:00	7	37	75	0	0	119	13	184	19	0	0	216	42	26	17	0	0	85	66	270	78	0	0	414	834	
08:45:00	6	27	63	0	0	96	5	164	14	0	0	183	36	22	2	0	1	60	82	317	49	0	2	448	787	
Hourly	33	138	294	0	0	465	36	775	46	0	0	857	146	80	41	0	1	267	272	1258	242	0	2	1772	3361	
***BREAK***																										
11:00:00	2	15	68	0	0	85	5	138	4	0	0	147	22	9	2	0	0	33	46	176	22	0	0	244	509	
11:15:00	5	15	54	0	0	74	5	168	5	0	0	178	20	15	4	0	0	39	52	177	28	0	0	257	548	
11:30:00	8	13	56	0	0	77	9	140	4	0	0	153	9	11	9	0	0	29	53	146	26	0	0	225	484	
11:45:00	4	14	43	0	0	61	5	158	5	0	0	168	27	10	8	0	1	45	49	189	25	1	0	264	538	
Hourly	19	57	221	0	0	297	24	604	18	0	0	646	78	45	23	0	1	146	200	688	101	1	0	990	2079	
12:00:00	7	20	49	0	1	76	11	136	7	0	0	154	24	9	10	0	0	43	51	195	27	0	0	273	546	
12:15:00	1	19	65	0	1	85	5	133	6	0	1	144	22	20	3	0	1	45	56	177	25	0	0	258	532	
12:30:00	6	14	50	0	0	70	5	172	6	1	0	184	20	16	7	0	0	43	58	198	23	2	0	281	578	
12:45:00	7	14	39	0	0	60	5	122	1	0	0	128	27	14	5	0	0	46	59	214	28	0	1	301	535	
Hourly	21	67	203	0	2	291	26	563	20	1	1	610	93	59	25	0	1	177	224	784	103	2	1	1113	2191	
13:00:00	5	13	54	0	0	72	7	156	5	0	0	168	16	10	10	0	0	36	52	185	34	0	0	271	547	
13:15:00	0	16	67	0	0	83	11	175	6	0	0	192	27	17	7	0	0	51	63	170	39	0	0	272	598	
13:30:00	5	14	68	0	0	87	10	181	4	0	0	195	18	22	7	0	0	47	67	184	32	2	0	285	614	
13:45:00	2	17	38	0	0	57	10	163	8	0	0	181	32	19	5	0	0	56	61	176	22	0	0	259	553	
Hourly	12	60	227	0	0	299	38	675	23	0	0	736	93	68	29	0	0	190	243	715	127	2	0	1087	2312	
***BREAK***																										
15:00:00	14	27	90	0	0	131	14	298	9	0	0	321	44	30	16	0	0	90	80	267	44	2	0	393	935	
15:15:00	7	21	55	0	0	83	18	259	6	0	0	283	63	38	9	0	0	110	70	263	38	1	0	372	848	
15:30:00	6	15	62	0	0	83	8	244	5	0	2	257	65	28	9	0	0	102	72	225	52	0	0	349	791	
15:45:00	7	37	73	0	0	117	15	310	6	0	0	331	43	32	16	0	1	91	72	266	60	0	0	398	937	
Hourly	34	100	280	0	0	414	55	1111	26	0	2	1192	215	128	50	0	1	393	294	1021	194	3	0	1512	3511	
16:00:00	13	33	82	0	0	128	13	282	12	0	0	307	58	38	14	0	0	110	66	246	65	1	1	378	923	
16:15:00	8	27	58	0	0	93	10	347	7	0	0	364	46	49	10	0	0	105	76	245	45	0	1	366	928	
16:30:00	4	24	87	0	0	115	15	265	10	1	0	291	53	54	13	0	0	120	68	259	41	0	0	368	894	
16:45:00	7	14	58	0	0	79	13	326	10	0	0	349	47	49	14	0	2	110	69	301	39	2	0	411	949	
Hourly	32	98	285	0	0	415	51	1220	39	1	0	1311	204	190	51	0	2	445	279	1051	190	3	2	1523	3694	
17:00:00	11	29	85	0	0	125	16	298	14	0	0	328	51	44	12	0	0	107	69	279	56	0	0	404	964	
17:15:00	7	20	79	0	1	106	12	354	17	1	4	384	50	46	12	0	3	108	73	313	47	0	0	433	1031	
17:30:00	15	30	105	0	1	150	7	282	12	0	1	301	47	60	11	0	0	118	75	274	51	1	0	401	970	
17:45:00	6	26	72	0	0	104	16	308	7	0	0	331	47	33	15	0	4	95	86	274	55	0	0	415	945	
Hourly	39	105	341	0	2	485	51	1242	50	1	5	1344	195	183	50	0	7	428	303	1140	209	1	0	1653	3910	
Grand Total	220	791	2127	0	4	3138	336	6852	250	3	8	7441	1123	805	285	0	15	2213	2091	7979	1378	13	7	11461	24253	
Approach%	7%	25.2%	67.8%	0%	-	-	4.5%	92.1%	3.4%	0%	-	-	50.7%	36.4%	12.9%	0%	-	-	18.2%	69.6%	12%	0.1%	-	-	-	
Totals %	0.9%	3.3%	8.8%	0%	-	12.9%	1.4%	28.3%	1%	0%	-	30.7%	4.6%	3.3%	1.2%	0%	-	9.1%	8.6%	32.9%	5.7%	0.1%	-	47.3%	-	



Turning Movement Count  
Location Name: DIXIE RD & MAYFIELD RD  
Date: Wed, Jun 01, 2022 Deployment Lead: Tasos Issaakidis

Peel Region  
SUITE B 10 PEEL CENTRE DR  
BRAMPTON ONTARIO, L6T 4B9  
CANADA

Heavy	43	39	208	0	-	46	1025	43	0	-	49	28	40	0	-	250	1098	37	0	-	-
Heavy %	19.5%	4.9%	9.8%	0%	-	13.7%	15%	17.2%	0%	-	4.4%	3.5%	14%	0%	-	12%	13.8%	2.7%	0%	-	-
Bicycles	-	-	-	-	-	-	-	-	-	-	-	-	-	-	-	-	-	-	-	-	-
Bicycle %	-	-	-	-	-	-	-	-	-	-	-	-	-	-	-	-	-	-	-	-	-



**Peak Hour: 08:00 AM - 09:00 AM Weather: Broken Clouds (23.15 °C)**

Start Time	Southbound DIXIE RD						Westbound MAYFIELD RD						Northbound DIXIE RD						Eastbound MAYFIELD RD						Int. Total (15 min)
	Left	Thru	Right	UTurn	Peds	Approach Total	Left	Thru	Right	UTurn	Peds	Approach Total	Left	Thru	Right	UTurn	Peds	Approach Total	Left	Thru	Right	UTurn	Peds	Approach Total	
08:00:00	9	42	79	0	0	130	10	227	6	0	0	243	40	18	13	0	0	71	62	351	60	0	0	473	917
08:15:00	11	32	77	0	0	120	8	200	7	0	0	215	28	14	9	0	0	51	62	320	55	0	0	437	823
08:30:00	7	37	75	0	0	119	13	184	19	0	0	216	42	26	17	0	0	85	66	270	78	0	0	414	834
08:45:00	6	27	63	0	0	96	5	164	14	0	0	183	36	22	2	0	1	60	82	317	49	0	2	448	787
<b>Grand Total</b>	<b>33</b>	<b>138</b>	<b>294</b>	<b>0</b>	<b>0</b>	<b>465</b>	<b>36</b>	<b>775</b>	<b>46</b>	<b>0</b>	<b>0</b>	<b>857</b>	<b>146</b>	<b>80</b>	<b>41</b>	<b>0</b>	<b>1</b>	<b>267</b>	<b>272</b>	<b>1258</b>	<b>242</b>	<b>0</b>	<b>2</b>	<b>1772</b>	<b>3361</b>
<b>Approach%</b>	7.1%	29.7%	63.2%	0%	-	-	4.2%	90.4%	5.4%	0%	-	-	54.7%	30%	15.4%	0%	-	-	15.3%	71%	13.7%	0%	-	-	-
<b>Totals %</b>	1%	4.1%	8.7%	0%	13.8%	13.8%	1.1%	23.1%	1.4%	0%	25.5%	25.5%	4.3%	2.4%	1.2%	0%	7.9%	7.9%	8.1%	37.4%	7.2%	0%	52.7%	52.7%	-
<b>PHF</b>	0.75	0.82	0.93	0	0.89	0.89	0.69	0.85	0.61	0	0.88	0.88	0.87	0.77	0.6	0	0.79	0.79	0.83	0.9	0.78	0	0.94	0.94	-
<b>Heavy</b>	5	11	20	0	36	36	5	136	5	0	146	146	7	4	6	0	17	17	26	122	5	0	153	153	-
<b>Heavy %</b>	15.2%	8%	6.8%	0%	7.7%	7.7%	13.9%	17.5%	10.9%	0%	17%	17%	4.8%	5%	14.6%	0%	6.4%	6.4%	9.6%	9.7%	2.1%	0%	8.6%	8.6%	-
<b>Lights</b>	28	127	274	0	429	429	31	639	41	0	711	711	139	76	35	0	250	250	246	1136	237	0	1619	1619	-
<b>Lights %</b>	84.8%	92%	93.2%	0%	92.3%	92.3%	86.1%	82.5%	89.1%	0%	83%	83%	95.2%	95%	85.4%	0%	93.6%	93.6%	90.4%	90.3%	97.9%	0%	91.4%	91.4%	-
<b>Single-Unit Trucks</b>	2	7	15	0	24	24	1	62	3	0	66	66	3	3	5	0	11	11	10	56	4	0	70	70	-
<b>Single-Unit Trucks %</b>	6.1%	5.1%	5.1%	0%	5.2%	5.2%	2.8%	8%	6.5%	0%	7.7%	7.7%	2.1%	3.8%	12.2%	0%	4.1%	4.1%	3.7%	4.5%	1.7%	0%	4%	4%	-
<b>Buses</b>	0	0	0	0	0	0	2	6	1	0	9	9	3	1	1	0	5	5	2	19	1	0	22	22	-
<b>Buses %</b>	0%	0%	0%	0%	0%	0%	5.6%	0.8%	2.2%	0%	1.1%	1.1%	2.1%	1.3%	2.4%	0%	1.9%	1.9%	0.7%	1.5%	0.4%	0%	1.2%	1.2%	-
<b>Articulated Trucks</b>	3	4	5	0	12	12	2	68	1	0	71	71	1	0	0	0	1	1	14	47	0	0	61	61	-
<b>Articulated Trucks %</b>	9.1%	2.9%	1.7%	0%	2.6%	2.6%	5.6%	8.8%	2.2%	0%	8.3%	8.3%	0.7%	0%	0%	0%	0.4%	0.4%	5.1%	3.7%	0%	0%	3.4%	3.4%	-
<b>Pedestrians</b>	-	-	-	0	-	-	-	-	-	0	-	-	-	-	-	0	-	-	-	-	-	2	-	-	-
<b>Pedestrians%</b>	-	-	-	0%	-	-	-	-	-	0%	-	-	-	-	-	0%	-	-	-	-	-	66.7%	-	-	-
<b>Bicycles on Crosswalk</b>	-	-	-	0	-	-	-	-	-	0	-	-	-	-	-	1	-	-	-	-	-	0	-	-	-
<b>Bicycles on Crosswalk%</b>	-	-	-	0%	-	-	-	-	-	0%	-	-	-	-	-	33.3%	-	-	-	-	-	0%	-	-	-



**Peak Hour: 01:00 PM - 02:00 PM Weather: Light Rain (18.78 °C)**

Start Time	Southbound DIXIE RD						Westbound MAYFIELD RD						Northbound DIXIE RD						Eastbound MAYFIELD RD						Int. Total (15 min)
	Left	Thru	Right	UTurn	Peds	Approach Total	Left	Thru	Right	UTurn	Peds	Approach Total	Left	Thru	Right	UTurn	Peds	Approach Total	Left	Thru	Right	UTurn	Peds	Approach Total	
13:00:00	5	13	54	0	0	72	7	156	5	0	0	168	16	10	10	0	0	36	52	185	34	0	0	271	547
13:15:00	0	16	67	0	0	83	11	175	6	0	0	192	27	17	7	0	0	51	63	170	39	0	0	272	598
13:30:00	5	14	68	0	0	87	10	181	4	0	0	195	18	22	7	0	0	47	67	184	32	2	0	285	614
13:45:00	2	17	38	0	0	57	10	163	8	0	0	181	32	19	5	0	0	56	61	176	22	0	0	259	553
<b>Grand Total</b>	<b>12</b>	<b>60</b>	<b>227</b>	<b>0</b>	<b>0</b>	<b>299</b>	<b>38</b>	<b>675</b>	<b>23</b>	<b>0</b>	<b>0</b>	<b>736</b>	<b>93</b>	<b>68</b>	<b>29</b>	<b>0</b>	<b>0</b>	<b>190</b>	<b>243</b>	<b>715</b>	<b>127</b>	<b>2</b>	<b>0</b>	<b>1087</b>	<b>2312</b>
<b>Approach%</b>	4%	20.1%	75.9%	0%	-	-	5.2%	91.7%	3.1%	0%	-	-	48.9%	35.8%	15.3%	0%	-	-	22.4%	65.8%	11.7%	0.2%	-	-	-
<b>Totals %</b>	0.5%	2.6%	9.8%	0%	12.9%	12.9%	1.6%	29.2%	1%	0%	31.8%	31.8%	4%	2.9%	1.3%	0%	8.2%	8.2%	10.5%	30.9%	5.5%	0.1%	47%	47%	-
<b>PHF</b>	0.6	0.88	0.83	0	0.86	0.86	0.86	0.93	0.72	0	0.94	0.94	0.73	0.77	0.73	0	0.85	0.85	0.91	0.97	0.81	0.25	0.95	0.95	-
<b>Heavy</b>	2	5	28	0	35	35	7	145	4	0	156	156	4	2	4	0	10	10	33	131	1	0	165	165	-
<b>Heavy %</b>	16.7%	8.3%	12.3%	0%	11.7%	11.7%	18.4%	21.5%	17.4%	0%	21.2%	21.2%	4.3%	2.9%	13.8%	0%	5.3%	5.3%	13.6%	18.3%	0.8%	0%	15.2%	15.2%	-
<b>Lights</b>	10	55	199	0	264	264	31	530	19	0	580	580	89	66	25	0	180	180	210	584	126	2	922	922	-
<b>Lights %</b>	83.3%	91.7%	87.7%	0%	88.3%	88.3%	81.6%	78.5%	82.6%	0%	78.8%	78.8%	95.7%	97.1%	86.2%	0%	94.7%	94.7%	86.4%	81.7%	99.2%	100%	84.8%	84.8%	-
<b>Single-Unit Trucks</b>	0	3	12	0	15	15	3	60	3	0	66	66	4	1	2	0	7	7	22	45	0	0	67	67	-
<b>Single-Unit Trucks %</b>	0%	5%	5.3%	0%	5%	5%	7.9%	8.9%	13%	0%	9%	9%	4.3%	1.5%	6.9%	0%	3.7%	3.7%	9.1%	6.3%	0%	0%	6.2%	6.2%	-
<b>Buses</b>	0	1	2	0	3	3	3	15	0	0	18	18	0	0	0	0	0	0	0	6	0	0	6	6	-
<b>Buses %</b>	0%	1.7%	0.9%	0%	1%	1%	7.9%	2.2%	0%	0%	2.4%	2.4%	0%	0%	0%	0%	0%	0%	0%	0.8%	0%	0%	0.6%	0.6%	-
<b>Articulated Trucks</b>	2	1	14	0	17	17	1	70	1	0	72	72	0	1	2	0	3	3	11	80	1	0	92	92	-
<b>Articulated Trucks %</b>	16.7%	1.7%	6.2%	0%	5.7%	5.7%	2.6%	10.4%	4.3%	0%	9.8%	9.8%	0%	1.5%	6.9%	0%	1.6%	1.6%	4.5%	11.2%	0.8%	0%	8.5%	8.5%	-
<b>Pedestrians</b>	-	-	-	0	-	-	-	-	-	0	-	-	-	-	-	0	-	-	-	-	-	0	-	-	-
<b>Pedestrians%</b>	-	-	-	0%	-	-	-	-	-	0%	-	-	-	-	-	0%	-	-	-	-	-	0%	-	-	-
<b>Bicycles on Crosswalk</b>	-	-	-	0	-	-	-	-	-	0	-	-	-	-	-	0	-	-	-	-	-	0	-	-	-
<b>Bicycles on Crosswalk%</b>	-	-	-	0%	-	-	-	-	-	0%	-	-	-	-	-	0%	-	-	-	-	-	0%	-	-	-



Peak Hour: 05:00 PM - 06:00 PM Weather: Broken Clouds (24.05 °C)

Start Time	Southbound DIXIE RD						Westbound MAYFIELD RD						Northbound DIXIE RD						Eastbound MAYFIELD RD						Int. Total (15 min)
	Left	Thru	Right	UTurn	Peds	Approach Total	Left	Thru	Right	UTurn	Peds	Approach Total	Left	Thru	Right	UTurn	Peds	Approach Total	Left	Thru	Right	UTurn	Peds	Approach Total	
17:00:00	11	29	85	0	0	125	16	298	14	0	0	328	51	44	12	0	0	107	69	279	56	0	0	404	964
17:15:00	7	20	79	0	1	106	12	354	17	1	4	384	50	46	12	0	3	108	73	313	47	0	0	433	1031
17:30:00	15	30	105	0	1	150	7	282	12	0	1	301	47	60	11	0	0	118	75	274	51	1	0	401	970
17:45:00	6	26	72	0	0	104	16	308	7	0	0	331	47	33	15	0	4	95	86	274	55	0	0	415	945
<b>Grand Total</b>	<b>39</b>	<b>105</b>	<b>341</b>	<b>0</b>	<b>2</b>	<b>485</b>	<b>51</b>	<b>1242</b>	<b>50</b>	<b>1</b>	<b>5</b>	<b>1344</b>	<b>195</b>	<b>183</b>	<b>50</b>	<b>0</b>	<b>7</b>	<b>428</b>	<b>303</b>	<b>1140</b>	<b>209</b>	<b>1</b>	<b>0</b>	<b>1653</b>	<b>3910</b>
<b>Approach%</b>	8%	21.6%	70.3%	0%	-	-	3.8%	92.4%	3.7%	0.1%	-	-	45.6%	42.8%	11.7%	0%	-	-	18.3%	69%	12.6%	0.1%	-	-	-
<b>Totals %</b>	1%	2.7%	8.7%	0%	12.4%	1.3%	31.8%	1.3%	0%	34.4%	5%	4.7%	1.3%	0%	10.9%	7.7%	29.2%	5.3%	0%	42.3%	-	-	-	-	
<b>PHF</b>	0.65	0.88	0.81	0	0.81	0.8	0.88	0.74	0.25	0.88	0.96	0.76	0.83	0	0.91	0.88	0.91	0.93	0.25	0.95	-	-	-	-	
<b>Heavy</b>	2	2	30	0	34	3	82	9	0	94	2	6	5	0	13	38	138	2	0	178	-	-	-	-	
<b>Heavy %</b>	5.1%	1.9%	8.8%	0%	7%	5.9%	6.6%	18%	0%	7%	1%	3.3%	10%	0%	3%	12.5%	12.1%	1%	0%	10.8%	-	-	-	-	
<b>Lights</b>	37	103	311	0	451	48	1160	41	1	1250	193	177	45	0	415	265	1002	207	1	1475	-	-	-	-	
<b>Lights %</b>	94.9%	98.1%	91.2%	0%	93%	94.1%	93.4%	82%	100%	93%	99%	96.7%	90%	0%	97%	87.5%	87.9%	99%	100%	89.2%	-	-	-	-	
<b>Single-Unit Trucks</b>	2	0	15	0	17	2	35	7	0	44	0	4	3	0	7	24	55	2	0	81	-	-	-	-	
<b>Single-Unit Trucks %</b>	5.1%	0%	4.4%	0%	3.5%	3.9%	2.8%	14%	0%	3.3%	0%	2.2%	6%	0%	1.6%	7.9%	4.8%	1%	0%	4.9%	-	-	-	-	
<b>Buses</b>	0	1	1	0	2	0	4	0	0	4	2	0	0	0	2	0	4	0	0	4	-	-	-	-	
<b>Buses %</b>	0%	1%	0.3%	0%	0.4%	0%	0.3%	0%	0%	0.3%	1%	0%	0%	0%	0.5%	0%	0.4%	0%	0%	0.2%	-	-	-	-	
<b>Articulated Trucks</b>	0	1	14	0	15	1	43	2	0	46	0	2	2	0	4	14	79	0	0	93	-	-	-	-	
<b>Articulated Trucks %</b>	0%	1%	4.1%	0%	3.1%	2%	3.5%	4%	0%	3.4%	0%	1.1%	4%	0%	0.9%	4.6%	6.9%	0%	0%	5.6%	-	-	-	-	
<b>Pedestrians</b>	-	-	-	-	2	-	-	-	-	5	-	-	-	4	-	-	-	-	-	0	-	-	-	-	
<b>Pedestrians%</b>	-	-	-	-	14.3%	-	-	-	-	35.7%	-	-	-	28.6%	-	-	-	-	-	0%	-	-	-	-	
<b>Bicycles on Crosswalk</b>	-	-	-	-	0	-	-	-	-	0	-	-	-	3	-	-	-	-	-	0	-	-	-	-	
<b>Bicycles on Crosswalk%</b>	-	-	-	-	0%	-	-	-	-	0%	-	-	-	21.4%	-	-	-	-	-	0%	-	-	-	-	

Peak Hour: 08:00 AM - 09:00 AM Weather: Broken Clouds (23.15 °C)

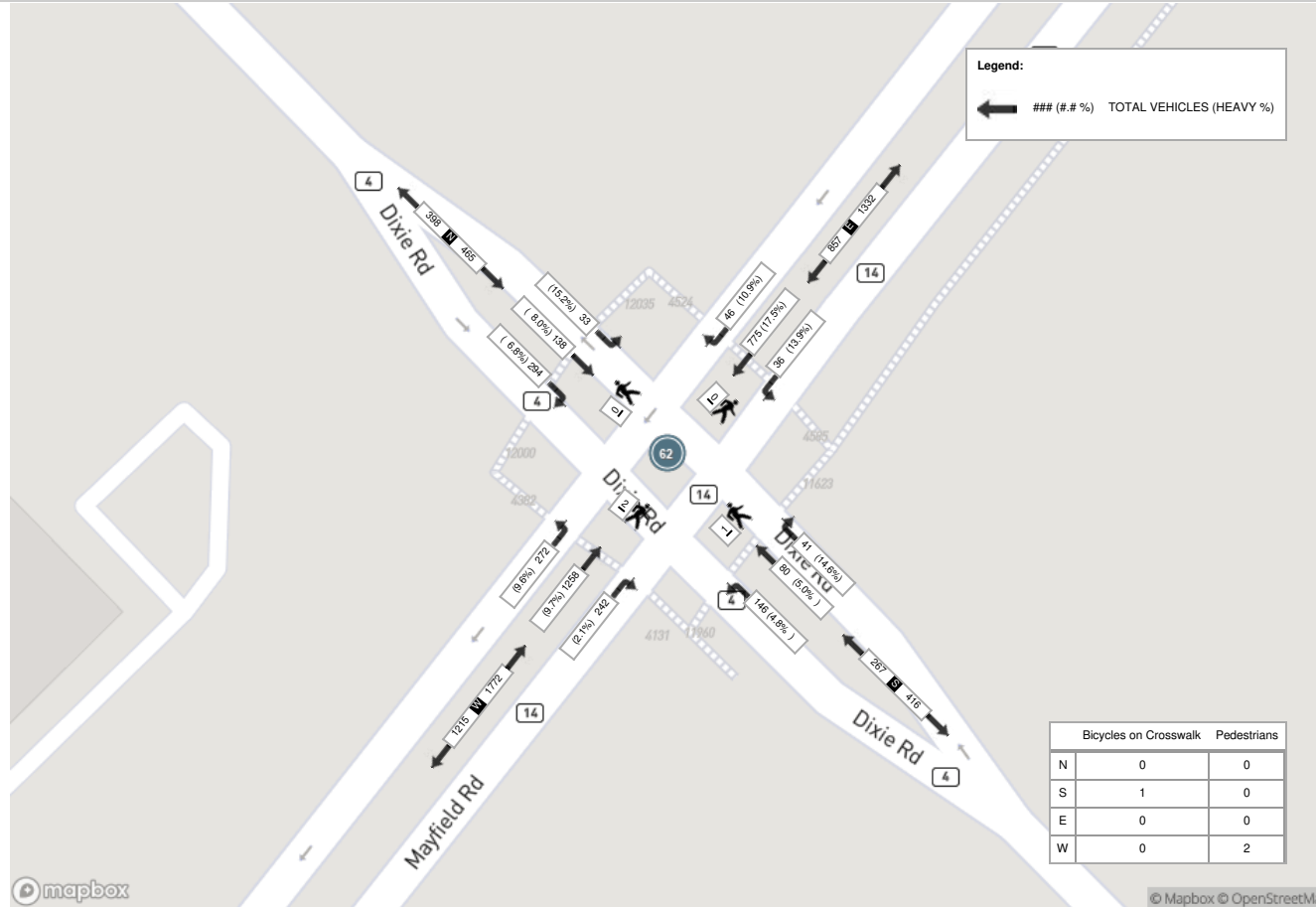

Peak Hour: 01:00 PM - 02:00 PM Weather: Light Rain (18.78 °C)

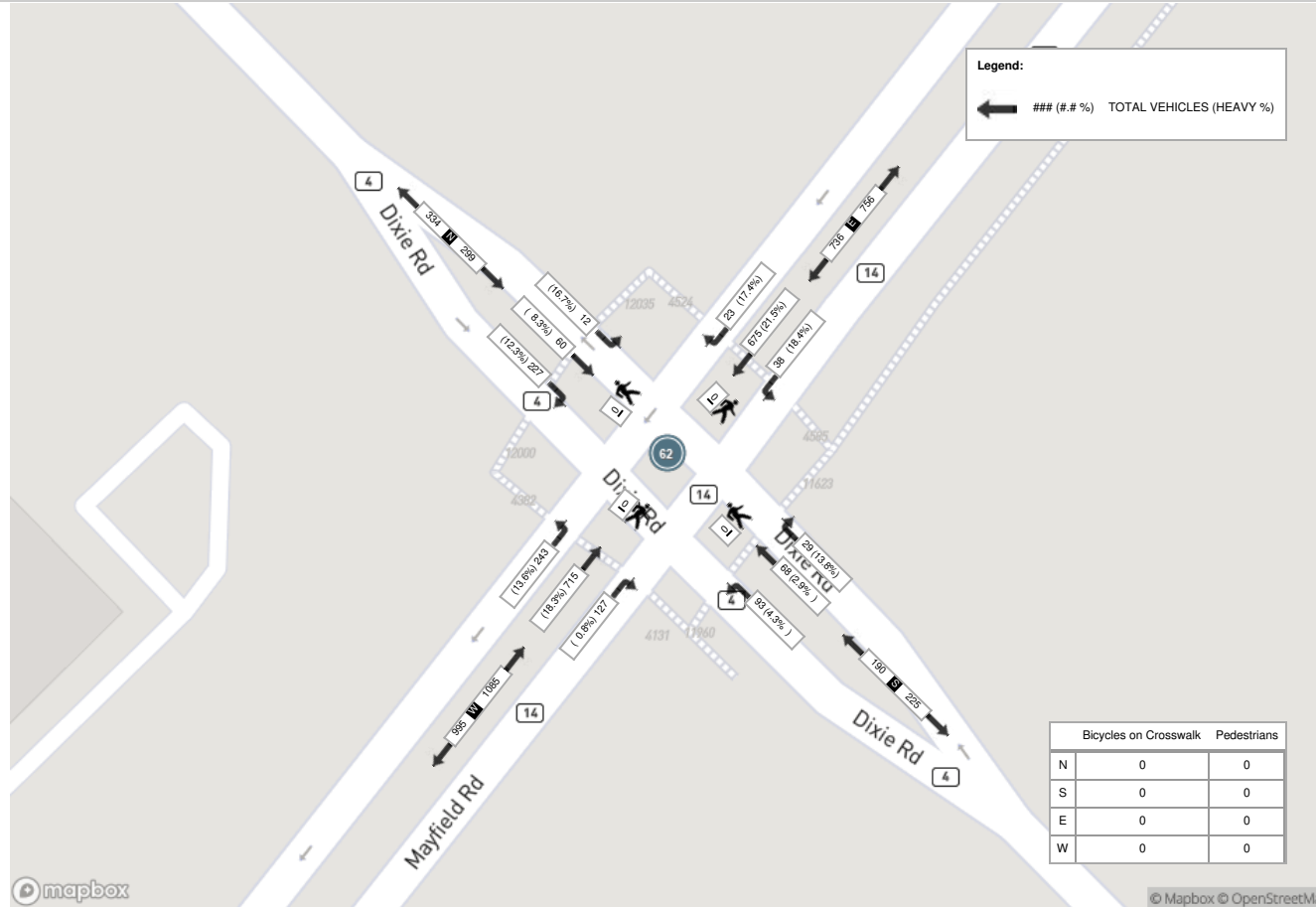

Peak Hour: 05:00 PM - 06:00 PM Weather: Broken Clouds (24.05 °C)

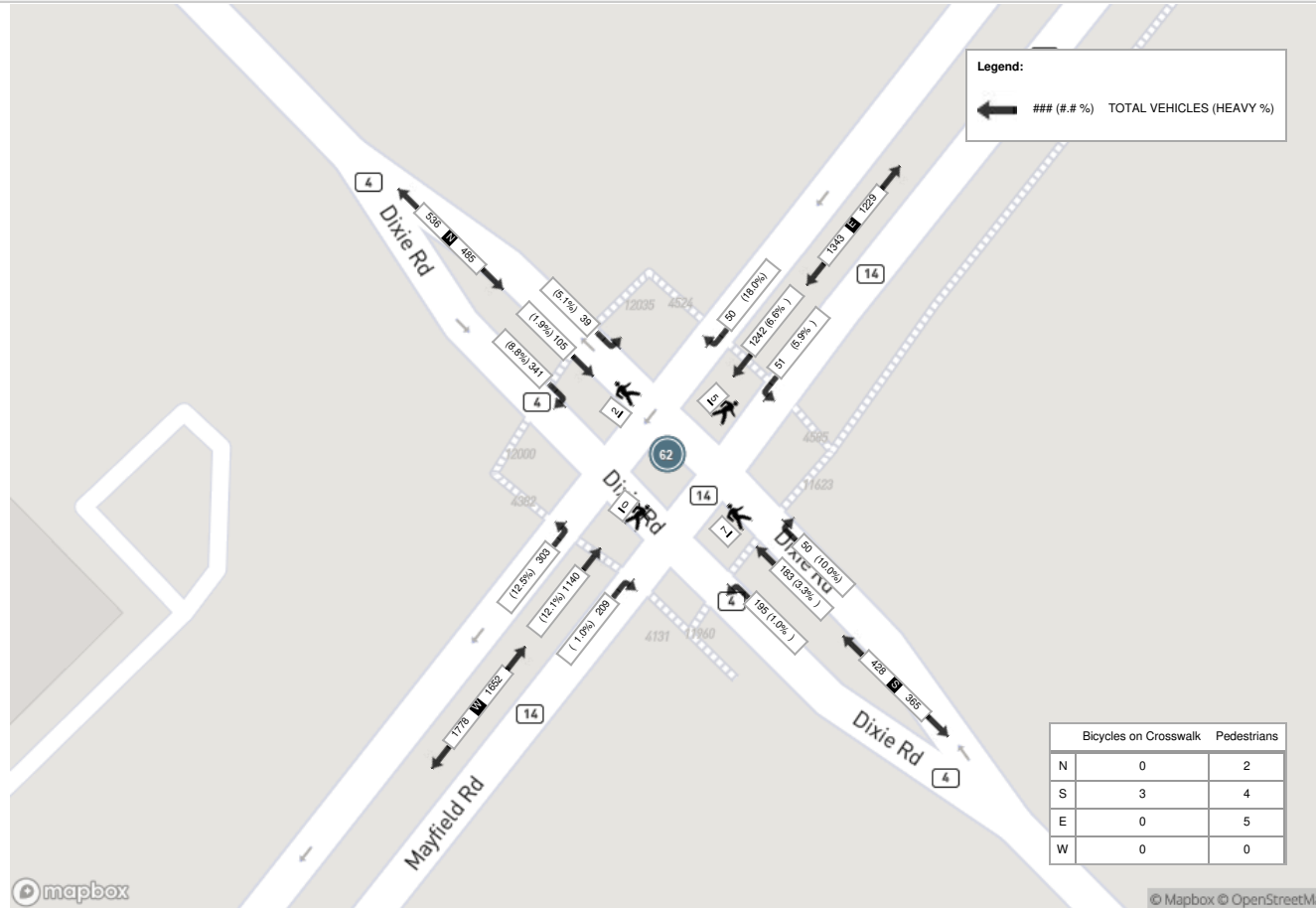





























## **Appendix B**

### Existing Intersection Operation Calculations (Synchro)

HCM Signalized Intersection Capacity Analysis  
101: Bramalea Rd & Mayfield Rd

Existing Conditions  
AM Peak Hour

												
Movement	EBL	EBT	EBR	WBL	WBT	WBR	NBL	NBT	NBR	SBL	SBT	SBR
Lane Configurations		  			  						 	
Traffic Volume (vph)	243	894	187	94	595	21	57	124	51	41	178	138
Future Volume (vph)	243	894	187	94	595	21	57	124	51	41	178	138
Ideal Flow (vphpl)	1900	1900	1900	1900	1900	1900	1900	1900	1900	1900	1900	1900
Lane Width	3.5	3.7	3.5	3.5	3.7	3.5	3.5	3.7	3.5	3.5	3.7	3.5
Total Lost time (s)	3.0	7.2	7.2	7.2	7.2	7.2	7.1	7.1	7.1	3.0	7.1	
Lane Util. Factor	1.00	0.91	1.00	1.00	0.91	1.00	1.00	1.00	1.00	1.00	0.95	
Frbp, ped/bikes	1.00	1.00	0.99	1.00	1.00	1.00	1.00	1.00	0.98	1.00	1.00	
Flpb, ped/bikes	1.00	1.00	1.00	1.00	1.00	1.00	1.00	1.00	1.00	1.00	1.00	
Frt	1.00	1.00	0.85	1.00	1.00	0.85	1.00	1.00	0.85	1.00	0.93	
Flt Protected	0.95	1.00	1.00	0.95	1.00	1.00	0.95	1.00	1.00	0.95	1.00	
Satd. Flow (prot)	1785	4683	1516	1608	4445	1157	1700	1847	1427	1590	3363	
Flt Permitted	0.39	1.00	1.00	0.31	1.00	1.00	0.56	1.00	1.00	0.56	1.00	
Satd. Flow (perm)	740	4683	1516	518	4445	1157	1002	1847	1427	930	3363	
Peak-hour factor, PHF	1.00	1.00	1.00	1.00	1.00	1.00	1.00	1.00	1.00	1.00	1.00	1.00
Adj. Flow (vph)	243	894	187	94	595	21	57	124	51	41	178	138
RTOR Reduction (vph)	0	0	67	0	0	10	0	0	44	0	109	0
Lane Group Flow (vph)	243	894	120	94	595	11	57	124	7	41	207	0
Confl. Peds. (#/hr)			2	2					9	9		
Heavy Vehicles (%)	0%	12%	4%	11%	18%	38%	5%	4%	10%	12%	1%	2%
Turn Type	pm+pt	NA	Perm	Perm	NA	Perm	Perm	NA	Perm	pm+pt	NA	
Protected Phases	5	2			6			4		3	8	
Permitted Phases	2		2	6		6	4		4	8		
Actuated Green, G (s)	62.4	62.4	62.4	52.4	52.4	52.4	13.7	13.7	13.7	20.7	20.7	
Effective Green, g (s)	62.4	62.4	62.4	52.4	52.4	52.4	13.7	13.7	13.7	20.7	20.7	
Actuated g/C Ratio	0.64	0.64	0.64	0.54	0.54	0.54	0.14	0.14	0.14	0.21	0.21	
Clearance Time (s)	3.0	7.2	7.2	7.2	7.2	7.2	7.1	7.1	7.1	3.0	7.1	
Vehicle Extension (s)	5.0	5.0	5.0	5.0	5.0	5.0	5.0	5.0	5.0	5.0	5.0	
Lane Grp Cap (vph)	549	3000	971	278	2391	622	140	259	200	224	714	
v/s Ratio Prot	c0.03	0.19			0.13			c0.07		0.01	c0.06	
v/s Ratio Perm	c0.25		0.08	0.18		0.01	0.06		0.01	0.03		
v/c Ratio	0.44	0.30	0.12	0.34	0.25	0.02	0.41	0.48	0.04	0.18	0.29	
Uniform Delay, d1	7.3	7.8	6.8	12.7	12.0	10.5	38.1	38.6	36.1	31.0	32.2	
Progression Factor	1.00	1.00	1.00	1.00	1.00	1.00	1.00	1.00	1.00	1.00	1.00	
Incremental Delay, d2	1.2	0.3	0.3	3.3	0.2	0.1	4.0	2.9	0.2	0.8	0.5	
Delay (s)	8.5	8.0	7.1	16.0	12.3	10.6	42.1	41.5	36.3	31.9	32.7	
Level of Service	A	A	A	B	B	B	D	D	D	C	C	
Approach Delay (s)		8.0			12.7			40.5			32.6	
Approach LOS		A			B			D			C	
<b>Intersection Summary</b>												
HCM 2000 Control Delay			15.5				HCM 2000 Level of Service				B	
HCM 2000 Volume to Capacity ratio			0.46									
Actuated Cycle Length (s)			97.4				Sum of lost time (s)				20.3	
Intersection Capacity Utilization			94.7%				ICU Level of Service				F	
Analysis Period (min)			15									
c	Critical Lane Group											

HCM Signalized Intersection Capacity Analysis  
102: Dixie Rd & Mayfield Rd

























Existing Conditions  
AM Peak Hour

Movement	EBL	EBT	EBR	WBL	WBT	WBR	NBL	NBT	NBR	SBL	SBT	SBR
Lane Configurations												
Traffic Volume (vph)	272	1258	242	36	775	46	146	80	41	33	138	294
Future Volume (vph)	272	1258	242	36	775	46	146	80	41	33	138	294
Ideal Flow (vphpl)	1900	1900	1900	1900	1900	1900	1900	1900	1900	1900	1900	1900
Lane Width	3.5	3.7	3.5	3.5	3.7	3.5	3.5	3.7	3.5	3.5	3.7	3.5
Total Lost time (s)	3.0	6.9	6.9	3.0	6.9		6.9	6.9	6.9	6.9	6.9	6.9
Lane Util. Factor	1.00	0.91	1.00	1.00	0.91		1.00	1.00	1.00	1.00	1.00	1.00
Frbp, ped/bikes	1.00	1.00	0.98	1.00	1.00		1.00	1.00	1.00	1.00	1.00	0.99
Flpb, ped/bikes	1.00	1.00	1.00	1.00	1.00		1.00	1.00	1.00	1.00	1.00	1.00
Frt	1.00	1.00	0.85	1.00	0.99		1.00	1.00	0.85	1.00	1.00	0.85
Flt Protected	0.95	1.00	1.00	0.95	1.00		0.95	1.00	1.00	0.95	1.00	1.00
Satd. Flow (prot)	1623	4768	1534	1566	4422		1698	1830	1389	1552	1779	1472
Flt Permitted	0.30	1.00	1.00	0.21	1.00		0.63	1.00	1.00	0.70	1.00	1.00
Satd. Flow (perm)	507	4768	1534	345	4422		1129	1830	1389	1152	1779	1472
Peak-hour factor, PHF	1.00	1.00	1.00	1.00	1.00	1.00	1.00	1.00	1.00	1.00	1.00	1.00
Adj. Flow (vph)	272	1258	242	36	775	46	146	80	41	33	138	294
RTOR Reduction (vph)	0	0	89	0	4	0	0	0	33	0	0	195
Lane Group Flow (vph)	272	1258	153	36	817	0	146	80	8	33	138	99
Confl. Peds. (#/hr)							2					2
Confl. Bikes (#/hr)			1									
Heavy Vehicles (%)	10%	10%	2%	14%	18%	11%	5%	5%	15%	15%	8%	7%
Turn Type	pm+pt	NA	Perm	pm+pt	NA		Perm	NA	Perm	Perm	NA	Perm
Protected Phases	5	2		1	6			4			8	
Permitted Phases	2		2	6			4		4	8		8
Actuated Green, G (s)	84.1	75.8	75.8	71.3	66.0		22.1	22.1	22.1	22.1	22.1	22.1
Effective Green, g (s)	84.1	75.8	75.8	71.3	66.0		22.1	22.1	22.1	22.1	22.1	22.1
Actuated g/C Ratio	0.70	0.63	0.63	0.59	0.55		0.18	0.18	0.18	0.18	0.18	0.18
Clearance Time (s)	3.0	6.9	6.9	3.0	6.9		6.9	6.9	6.9	6.9	6.9	6.9
Vehicle Extension (s)	5.0	5.0	5.0	5.0	5.0		5.0	5.0	5.0	5.0	5.0	5.0
Lane Grp Cap (vph)	495	3011	968	258	2432		207	337	255	212	327	271
v/s Ratio Prot	c0.07	0.26		0.01	0.18			0.04			0.08	
v/s Ratio Perm	c0.32		0.10	0.08			c0.13		0.01	0.03		0.07
v/c Ratio	0.55	0.42	0.16	0.14	0.34		0.71	0.24	0.03	0.16	0.42	0.37
Uniform Delay, d1	6.8	11.1	9.0	10.1	14.9		45.9	41.8	40.2	41.1	43.3	42.8
Progression Factor	1.00	1.00	1.00	1.00	1.00		1.00	1.00	1.00	1.00	1.00	1.00
Incremental Delay, d2	2.2	0.4	0.3	0.5	0.4		12.9	0.8	0.1	0.7	1.8	1.7
Delay (s)	9.0	11.5	9.4	10.6	15.3		58.8	42.5	40.3	41.8	45.1	44.6
Level of Service	A	B	A	B	B		E	D	D	D	D	D
Approach Delay (s)		10.8			15.1			51.1			44.5	
Approach LOS		B			B			D			D	
<b>Intersection Summary</b>												
HCM 2000 Control Delay			19.8			HCM 2000 Level of Service			B			
HCM 2000 Volume to Capacity ratio			0.60									
Actuated Cycle Length (s)			120.0			Sum of lost time (s)			16.8			
Intersection Capacity Utilization			69.0%			ICU Level of Service			C			
Analysis Period (min)			15									

c Critical Lane Group

HCM Signalized Intersection Capacity Analysis  
101: Bramalea Rd & Mayfield Rd

Existing Conditions  
PM Peak Hour

												
Movement	EBL	EBT	EBR	WBL	WBT	WBR	NBL	NBT	NBR	SBL	SBT	SBR
Lane Configurations												
Traffic Volume (vph)	121	771	123	102	868	21	223	148	51	23	90	77
Future Volume (vph)	121	771	123	102	868	21	223	148	51	23	90	77
Ideal Flow (vphpl)	1900	1900	1900	1900	1900	1900	1900	1900	1900	1900	1900	1900
Lane Width	3.5	3.7	3.5	3.5	3.7	3.5	3.5	3.7	3.5	3.5	3.7	3.5
Total Lost time (s)	3.0	7.2	7.2	7.2	7.2	7.2	7.1	7.1	7.1	3.0	7.1	
Lane Util. Factor	1.00	0.91	1.00	1.00	0.91	1.00	1.00	1.00	1.00	1.00	0.95	
Frbp, ped/bikes	1.00	1.00	0.99	1.00	1.00	0.97	1.00	1.00	0.99	1.00	0.99	
Flpb, ped/bikes	1.00	1.00	1.00	1.00	1.00	1.00	1.00	1.00	1.00	1.00	1.00	
Frt	1.00	1.00	0.85	1.00	1.00	0.85	1.00	1.00	0.85	1.00	0.93	
Flt Protected	0.95	1.00	1.00	0.95	1.00	1.00	0.95	1.00	1.00	0.95	1.00	
Satd. Flow (prot)	1767	4683	1545	1784	4856	1481	1766	1921	1576	1785	3284	
Flt Permitted	0.27	1.00	1.00	0.35	1.00	1.00	0.65	1.00	1.00	0.59	1.00	
Satd. Flow (perm)	500	4683	1545	653	4856	1481	1202	1921	1576	1111	3284	
Peak-hour factor, PHF	1.00	1.00	1.00	1.00	1.00	1.00	1.00	1.00	1.00	1.00	1.00	1.00
Adj. Flow (vph)	121	771	123	102	868	21	223	148	51	23	90	77
RTOR Reduction (vph)	0	0	53	0	0	11	0	0	38	0	54	0
Lane Group Flow (vph)	121	771	70	102	868	10	223	148	13	23	113	0
Confl. Peds. (#/hr)	6		2	2		6	1					1
Confl. Bikes (#/hr)									1			
Heavy Vehicles (%)	1%	12%	2%	0%	8%	5%	1%	0%	0%	0%	1%	5%
Turn Type	pm+pt	NA	Perm	Perm	NA	Perm	Perm	NA	Perm	pm+pt	NA	
Protected Phases	5	2			6			4		3	8	
Permitted Phases	2		2	6		6	4		4	8		
Actuated Green, G (s)	62.9	62.9	62.9	52.8	52.8	52.8	27.6	27.6	27.6	33.1	33.1	
Effective Green, g (s)	62.9	62.9	62.9	52.8	52.8	52.8	27.6	27.6	27.6	33.1	33.1	
Actuated g/C Ratio	0.57	0.57	0.57	0.48	0.48	0.48	0.25	0.25	0.25	0.30	0.30	
Clearance Time (s)	3.0	7.2	7.2	7.2	7.2	7.2	7.1	7.1	7.1	3.0	7.1	
Vehicle Extension (s)	5.0	5.0	5.0	5.0	5.0	5.0	5.0	5.0	5.0	5.0	5.0	
Lane Grp Cap (vph)	366	2670	881	312	2324	708	300	480	394	348	985	
v/s Ratio Prot	c0.02	0.16			c0.18			0.08		0.00	c0.03	
v/s Ratio Perm	0.17		0.05	0.16		0.01	c0.19		0.01	0.02		
v/c Ratio	0.33	0.29	0.08	0.33	0.37	0.01	0.74	0.31	0.03	0.07	0.11	
Uniform Delay, d1	11.3	12.2	10.7	17.8	18.3	15.1	38.1	33.6	31.3	27.4	28.0	
Progression Factor	1.00	1.00	1.00	1.00	1.00	1.00	1.00	1.00	1.00	1.00	1.00	
Incremental Delay, d2	1.1	0.3	0.2	2.8	0.5	0.0	11.4	0.8	0.1	0.2	0.1	
Delay (s)	12.4	12.5	10.8	20.5	18.7	15.1	49.5	34.4	31.3	27.6	28.1	
Level of Service	B	B	B	C	B	B	D	C	C	C	C	
Approach Delay (s)		12.3			18.8			42.0			28.0	
Approach LOS		B			B			D			C	
<b>Intersection Summary</b>												
HCM 2000 Control Delay			20.7		HCM 2000 Level of Service					C		
HCM 2000 Volume to Capacity ratio			0.48									
Actuated Cycle Length (s)			110.3		Sum of lost time (s)					20.3		
Intersection Capacity Utilization			97.4%		ICU Level of Service					F		
Analysis Period (min)			15									

c Critical Lane Group

HCM Signalized Intersection Capacity Analysis  
102: Dixie Rd & Mayfield Rd

Existing Conditions  
PM Peak Hour

Movement	EBL	EBT	EBR	WBL	WBT	WBR	NBL	NBT	NBR	SBL	SBT	SBR
Lane Configurations												
Traffic Volume (vph)	303	1140	209	51	1242	50	195	183	50	39	105	341
Future Volume (vph)	303	1140	209	51	1242	50	195	183	50	39	105	341
Ideal Flow (vphpl)	1900	1900	1900	1900	1900	1900	1900	1900	1900	1900	1900	1900
Lane Width	3.5	3.7	3.5	3.5	3.7	3.5	3.5	3.7	3.5	3.5	3.7	3.5
Total Lost time (s)	3.0	6.9	6.9	3.0	6.9		6.9	6.9	6.9	6.9	6.9	6.9
Lane Util. Factor	1.00	0.91	1.00	1.00	0.91		1.00	1.00	1.00	1.00	1.00	1.00
Frbp, ped/bikes	1.00	1.00	1.00	1.00	1.00		1.00	1.00	0.99	1.00	1.00	0.98
Flpb, ped/bikes	1.00	1.00	1.00	1.00	1.00		1.00	1.00	1.00	1.00	1.00	1.00
Frt	1.00	1.00	0.85	1.00	0.99		1.00	1.00	0.85	1.00	1.00	0.85
Flt Protected	0.95	1.00	1.00	0.95	1.00		0.95	1.00	1.00	0.95	1.00	1.00
Satd. Flow (prot)	1579	4683	1581	1684	4849		1762	1865	1432	1698	1883	1439
Flt Permitted	0.12	1.00	1.00	0.24	1.00		0.69	1.00	1.00	0.55	1.00	1.00
Satd. Flow (perm)	195	4683	1581	420	4849		1279	1865	1432	984	1883	1439
Peak-hour factor, PHF	1.00	1.00	1.00	1.00	1.00	1.00	1.00	1.00	1.00	1.00	1.00	1.00
Adj. Flow (vph)	303	1140	209	51	1242	50	195	183	50	39	105	341
RTOR Reduction (vph)	0	0	87	0	3	0	0	0	39	0	0	225
Lane Group Flow (vph)	303	1140	122	51	1289	0	195	183	11	39	105	116
Confl. Peds. (#/hr)	5					5	4		2	2		4
Confl. Bikes (#/hr)												3
Heavy Vehicles (%)	13%	12%	1%	6%	7%	18%	1%	3%	10%	5%	2%	9%
Turn Type	pm+pt	NA	Perm	pm+pt	NA		Perm	NA	Perm	Perm	NA	Perm
Protected Phases	5	2		1	6			4			8	
Permitted Phases	2		2	6			4		4	8		8
Actuated Green, G (s)	80.1	69.9	69.9	55.7	48.5		26.1	26.1	26.1	26.1	26.1	26.1
Effective Green, g (s)	80.1	69.9	69.9	55.7	48.5		26.1	26.1	26.1	26.1	26.1	26.1
Actuated g/C Ratio	0.67	0.58	0.58	0.46	0.40		0.22	0.22	0.22	0.22	0.22	0.22
Clearance Time (s)	3.0	6.9	6.9	3.0	6.9		6.9	6.9	6.9	6.9	6.9	6.9
Vehicle Extension (s)	5.0	5.0	5.0	5.0	5.0		5.0	5.0	5.0	5.0	5.0	5.0
Lane Grp Cap (vph)	460	2727	920	270	1959		278	405	311	214	409	312
v/s Ratio Prot	c0.16	0.24		0.01	0.27			0.10			0.06	
v/s Ratio Perm	c0.28		0.08	0.08			c0.15		0.01	0.04		0.08
v/c Ratio	0.66	0.42	0.13	0.19	0.66		0.70	0.45	0.03	0.18	0.26	0.37
Uniform Delay, d1	23.0	13.8	11.3	17.8	29.0		43.4	40.7	37.0	38.3	38.9	40.0
Progression Factor	1.00	1.00	1.00	1.00	1.00		1.00	1.00	1.00	1.00	1.00	1.00
Incremental Delay, d2	4.5	0.5	0.3	0.7	1.6		9.7	1.7	0.1	0.9	0.7	1.6
Delay (s)	27.6	14.3	11.6	18.4	30.7		53.0	42.4	37.1	39.1	39.6	41.6
Level of Service	C	B	B	B	C		D	D	D	D	D	D
Approach Delay (s)		16.4			30.2			46.6			40.9	
Approach LOS		B			C			D			D	
<b>Intersection Summary</b>												
HCM 2000 Control Delay			27.5			HCM 2000 Level of Service			C			
HCM 2000 Volume to Capacity ratio			0.69									
Actuated Cycle Length (s)			120.0			Sum of lost time (s)			16.8			
Intersection Capacity Utilization			93.7%			ICU Level of Service			F			
Analysis Period (min)			15									

c Critical Lane Group

Queues  
101: Bramalea Rd & Mayfield Rd

Existing Conditions  
AM Peak Hour



Lane Group	EBL	EBT	EBR	WBL	WBT	WBR	NBL	NBT	NBR	SBL	SBT
Lane Group Flow (vph)	243	894	187	94	595	21	57	124	51	41	316
v/c Ratio	0.41	0.29	0.18	0.33	0.25	0.03	0.40	0.47	0.19	0.15	0.40
Control Delay	8.7	8.5	1.8	18.7	12.9	0.1	47.4	44.9	4.9	28.0	19.0
Queue Delay	0.0	0.0	0.0	0.0	0.0	0.0	0.0	0.0	0.0	0.0	0.0
Total Delay	8.7	8.5	1.8	18.7	12.9	0.1	47.4	44.9	4.9	28.0	19.0
Queue Length 50th (m)	15.3	25.2	0.0	9.4	20.6	0.0	9.4	20.8	0.0	5.4	13.5
Queue Length 95th (m)	27.8	35.7	7.6	22.6	29.7	0.0	20.7	36.8	4.3	12.7	23.9
Internal Link Dist (m)		182.8			347.4			479.0			343.8
Turn Bay Length (m)	180.0		110.0	80.0		100.0	100.0			110.0	
Base Capacity (vph)	589	3038	1048	282	2418	666	534	985	797	275	2195
Starvation Cap Reductn	0	0	0	0	0	0	0	0	0	0	0
Spillback Cap Reductn	0	0	0	0	0	0	0	0	0	0	0
Storage Cap Reductn	0	0	0	0	0	0	0	0	0	0	0
Reduced v/c Ratio	0.41	0.29	0.18	0.33	0.25	0.03	0.11	0.13	0.06	0.15	0.14

Intersection Summary

Queues  
102: Dixie Rd & Mayfield Rd

Existing Conditions  
AM Peak Hour



Lane Group	EBL	EBT	EBR	WBL	WBT	NBL	NBT	NBR	SBL	SBT	SBR
Lane Group Flow (vph)	272	1258	242	36	821	146	80	41	33	138	294
v/c Ratio	0.53	0.41	0.23	0.12	0.34	0.70	0.24	0.12	0.16	0.42	0.63
Control Delay	10.0	12.7	2.3	7.3	16.8	62.6	41.2	0.8	39.6	45.6	15.5
Queue Delay	0.0	0.0	0.0	0.0	0.0	0.0	0.0	0.0	0.0	0.0	0.0
Total Delay	10.0	12.7	2.3	7.3	16.8	62.6	41.2	0.8	39.6	45.6	15.5
Queue Length 50th (m)	16.5	49.9	0.0	1.9	33.6	30.0	15.0	0.0	6.1	26.8	10.2
Queue Length 95th (m)	33.9	74.6	11.0	5.9	54.9	46.4	25.3	0.0	13.3	40.4	32.5
Internal Link Dist (m)		507.8			328.1		418.0			489.9	
Turn Bay Length (m)	170.0		100.0	150.0		120.0		50.0	80.0		170.0
Base Capacity (vph)	514	3057	1070	309	2435	433	703	589	442	683	712
Starvation Cap Reductn	0	0	0	0	0	0	0	0	0	0	0
Spillback Cap Reductn	0	0	0	0	0	0	0	0	0	0	0
Storage Cap Reductn	0	0	0	0	0	0	0	0	0	0	0
Reduced v/c Ratio	0.53	0.41	0.23	0.12	0.34	0.34	0.11	0.07	0.07	0.20	0.41

Intersection Summary

Queues  
101: Bramalea Rd & Mayfield Rd

Existing Conditions  
PM Peak Hour



Lane Group	EBL	EBT	EBR	WBL	WBT	WBR	NBL	NBT	NBR	SBL	SBT
Lane Group Flow (vph)	121	771	123	102	868	21	223	148	51	23	167
v/c Ratio	0.31	0.28	0.13	0.32	0.37	0.03	0.73	0.30	0.11	0.06	0.17
Control Delay	13.6	13.7	3.3	24.8	19.9	0.0	51.9	34.1	2.7	22.8	14.5
Queue Delay	0.0	0.0	0.0	0.0	0.0	0.0	0.0	0.0	0.0	0.0	0.0
Total Delay	13.6	13.7	3.3	24.8	19.9	0.0	51.9	34.1	2.7	22.8	14.5
Queue Length 50th (m)	8.0	23.6	0.0	10.8	34.6	0.0	37.5	21.9	0.0	3.0	6.6
Queue Length 95th (m)	23.8	48.4	9.2	31.6	63.8	0.0	67.6	40.6	3.3	7.9	13.3
Internal Link Dist (m)		182.8			347.4			479.0			343.8
Turn Bay Length (m)	180.0		110.0	80.0		100.0	100.0			110.0	
Base Capacity (vph)	392	2715	947	317	2361	760	572	916	794	404	1907
Starvation Cap Reductn	0	0	0	0	0	0	0	0	0	0	0
Spillback Cap Reductn	0	0	0	0	0	0	0	0	0	0	0
Storage Cap Reductn	0	0	0	0	0	0	0	0	0	0	0
Reduced v/c Ratio	0.31	0.28	0.13	0.32	0.37	0.03	0.39	0.16	0.06	0.06	0.09

Intersection Summary

Queues  
102: Dixie Rd & Mayfield Rd

Existing Conditions  
PM Peak Hour



Lane Group	EBL	EBT	EBR	WBL	WBT	NBL	NBT	NBR	SBL	SBT	SBR
Lane Group Flow (vph)	303	1140	209	51	1292	195	183	50	39	105	341
v/c Ratio	0.65	0.41	0.21	0.17	0.66	0.70	0.45	0.13	0.18	0.26	0.64
Control Delay	27.6	15.9	2.8	10.9	32.0	55.9	42.8	1.9	37.1	38.3	12.9
Queue Delay	0.0	0.0	0.0	0.0	0.0	0.0	0.0	0.0	0.0	0.0	0.0
Total Delay	27.6	15.9	2.8	10.9	32.0	55.9	42.8	1.9	37.1	38.3	12.9
Queue Length 50th (m)	36.2	48.4	0.0	3.0	81.6	39.5	34.9	0.0	7.0	19.1	9.6
Queue Length 95th (m)	71.1	73.7	11.5	8.7	108.9	56.4	48.7	2.0	14.2	29.5	32.5
Internal Link Dist (m)		507.8			328.1		418.0			489.9	
Turn Bay Length (m)	170.0		100.0	150.0		120.0		50.0	80.0		170.0
Base Capacity (vph)	466	2748	1014	305	1961	490	716	605	377	723	729
Starvation Cap Reductn	0	0	0	0	0	0	0	0	0	0	0
Spillback Cap Reductn	0	0	0	0	0	0	0	0	0	0	0
Storage Cap Reductn	0	0	0	0	0	0	0	0	0	0	0
Reduced v/c Ratio	0.65	0.41	0.21	0.17	0.66	0.40	0.26	0.08	0.10	0.15	0.47





























Intersection Summary

## **Appendix C**

### **Future (2027) Background Intersection Operation Calculations (Synchro)**

HCM Signalized Intersection Capacity Analysis  
101: Bramalea Rd & Mayfield Rd

2027 Future Background Conditions  
AM Peak Hour

														
Movement	EBL	EBT	EBR	WBL	WBT	WBR	NBL	NBT	NBR	SBL	SBT	SBR		
Lane Configurations		  			  						 			
Traffic Volume (vph)	289	1070	222	112	763	25	68	147	61	49	211	164		
Future Volume (vph)	289	1070	222	112	763	25	68	147	61	49	211	164		
Ideal Flow (vphpl)	1900	1900	1900	1900	1900	1900	1900	1900	1900	1900	1900	1900		
Lane Width	3.5	3.7	3.5	3.5	3.7	3.5	3.5	3.7	3.5	3.5	3.7	3.5		
Total Lost time (s)	3.0	7.2	7.2	7.2	7.2	7.2	7.1	7.1	7.1	3.0	7.1			
Lane Util. Factor	1.00	0.91	1.00	1.00	0.91	1.00	1.00	1.00	1.00	1.00	0.95			
Frpb, ped/bikes	1.00	1.00	0.99	1.00	1.00	1.00	1.00	1.00	0.98	1.00	1.00			
Flpb, ped/bikes	1.00	1.00	1.00	1.00	1.00	1.00	1.00	1.00	1.00	1.00	1.00			
Frt	1.00	1.00	0.85	1.00	1.00	0.85	1.00	1.00	0.85	1.00	0.93			
Flt Protected	0.95	1.00	1.00	0.95	1.00	1.00	0.95	1.00	1.00	0.95	1.00			
Satd. Flow (prot)	1785	4683	1515	1608	4445	1157	1700	1847	1427	1590	3362			
Flt Permitted	0.32	1.00	1.00	0.26	1.00	1.00	0.53	1.00	1.00	0.54	1.00			
Satd. Flow (perm)	604	4683	1515	432	4445	1157	947	1847	1427	901	3362			
Peak-hour factor, PHF	1.00	1.00	1.00	1.00	1.00	1.00	1.00	1.00	1.00	1.00	1.00	1.00		
Adj. Flow (vph)	289	1070	222	112	763	25	68	147	61	49	211	164		
RTOR Reduction (vph)	0	0	84	0	0	12	0	0	52	0	125	0		
Lane Group Flow (vph)	289	1070	138	112	763	13	68	147	9	49	250	0		
Confl. Peds. (#/hr)			2	2					9	9				
Heavy Vehicles (%)	0%	12%	4%	11%	18%	38%	5%	4%	10%	12%	1%	2%		
Turn Type	pm+pt	NA	Perm	Perm	NA	Perm	Perm	NA	Perm	pm+pt	NA			
Protected Phases	5	2			6			4		3	8			
Permitted Phases	2		2	6		6	4		4	8				
Actuated Green, G (s)	62.3	62.3	62.3	52.3	52.3	52.3	15.3	15.3	15.3	23.7	23.7			
Effective Green, g (s)	62.3	62.3	62.3	52.3	52.3	52.3	15.3	15.3	15.3	23.7	23.7			
Actuated g/C Ratio	0.62	0.62	0.62	0.52	0.52	0.52	0.15	0.15	0.15	0.24	0.24			
Clearance Time (s)	3.0	7.2	7.2	7.2	7.2	7.2	7.1	7.1	7.1	3.0	7.1			
Vehicle Extension (s)	5.0	5.0	5.0	5.0	5.0	5.0	5.0	5.0	5.0	5.0	5.0			
Lane Grp Cap (vph)	457	2908	941	225	2317	603	144	281	217	249	794			
v/s Ratio Prot	c0.04	0.23			0.17			c0.08		0.01	c0.07			
v/s Ratio Perm	c0.35		0.09	0.26		0.01	0.07		0.01	0.04				
v/c Ratio	0.63	0.37	0.15	0.50	0.33	0.02	0.47	0.52	0.04	0.20	0.31			
Uniform Delay, d1	8.9	9.3	7.9	15.5	13.9	11.6	38.8	39.1	36.3	30.2	31.6			
Progression Factor	1.00	1.00	1.00	1.00	1.00	1.00	1.00	1.00	1.00	1.00	1.00			
Incremental Delay, d2	3.9	0.4	0.3	7.7	0.4	0.1	5.0	3.3	0.2	0.8	0.5			
Delay (s)	12.9	9.7	8.2	23.2	14.2	11.7	43.9	42.5	36.4	31.1	32.1			
Level of Service	B	A	A	C	B	B	D	D	D	C	C			
Approach Delay (s)		10.1			15.3			41.5			32.0			
Approach LOS		B			B			D			C			
<b>Intersection Summary</b>														
HCM 2000 Control Delay			17.2									HCM 2000 Level of Service	B	
HCM 2000 Volume to Capacity ratio			0.61											
Actuated Cycle Length (s)			100.3								20.3			
Intersection Capacity Utilization			95.5%										ICU Level of Service	F
Analysis Period (min)			15											
c	Critical Lane Group													

HCM Signalized Intersection Capacity Analysis  
102: Dixie Rd & Mayfield Rd

2027 Future Background Conditions  
AM Peak Hour

Movement	EBL	EBT	EBR	WBL	WBT	WBR	NBL	NBT	NBR	SBL	SBT	SBR
Lane Configurations												
Traffic Volume (vph)	528	1569	287	47	951	85	173	159	72	44	180	452
Future Volume (vph)	528	1569	287	47	951	85	173	159	72	44	180	452
Ideal Flow (vphpl)	1900	1900	1900	1900	1900	1900	1900	1900	1900	1900	1900	1900
Lane Width	3.5	3.7	3.5	3.5	3.7	3.5	3.5	3.7	3.5	3.5	3.7	3.5
Total Lost time (s)	3.0	6.9	6.9	3.0	6.9		6.9	6.9	6.9	6.9	6.9	6.9
Lane Util. Factor	1.00	0.91	1.00	1.00	0.91		1.00	1.00	1.00	1.00	1.00	1.00
Frbp, ped/bikes	1.00	1.00	0.98	1.00	1.00		1.00	1.00	1.00	1.00	1.00	0.99
Flpb, ped/bikes	1.00	1.00	1.00	1.00	1.00		1.00	1.00	1.00	1.00	1.00	1.00
Frt	1.00	1.00	0.85	1.00	0.99		1.00	1.00	0.85	1.00	1.00	0.85
Flt Protected	0.95	1.00	1.00	0.95	1.00		0.95	1.00	1.00	0.95	1.00	1.00
Satd. Flow (prot)	1623	4768	1533	1566	4411		1698	1830	1389	1552	1779	1472
Flt Permitted	0.18	1.00	1.00	0.15	1.00		0.58	1.00	1.00	0.62	1.00	1.00
Satd. Flow (perm)	300	4768	1533	248	4411		1043	1830	1389	1015	1779	1472
Peak-hour factor, PHF	1.00	1.00	1.00	1.00	1.00	1.00	1.00	1.00	1.00	1.00	1.00	1.00
Adj. Flow (vph)	528	1569	287	47	951	85	173	159	72	44	180	452
RTOR Reduction (vph)	0	0	132	0	9	0	0	0	53	0	0	156
Lane Group Flow (vph)	528	1569	155	47	1027	0	173	159	19	44	180	296
Confl. Peds. (#/hr)							2					2
Confl. Bikes (#/hr)			1									
Heavy Vehicles (%)	10%	10%	2%	14%	18%	11%	5%	5%	15%	15%	8%	7%
Turn Type	pm+pt	NA	Perm	pm+pt	NA		Perm	NA	Perm	Perm	NA	Perm
Protected Phases	5	2		1	6			4			8	
Permitted Phases	2		2	6			4		4	8		8
Actuated Green, G (s)	74.7	65.0	65.0	51.8	45.1		31.5	31.5	31.5	31.5	31.5	31.5
Effective Green, g (s)	74.7	65.0	65.0	51.8	45.1		31.5	31.5	31.5	31.5	31.5	31.5
Actuated g/C Ratio	0.62	0.54	0.54	0.43	0.38		0.26	0.26	0.26	0.26	0.26	0.26
Clearance Time (s)	3.0	6.9	6.9	3.0	6.9		6.9	6.9	6.9	6.9	6.9	6.9
Vehicle Extension (s)	5.0	5.0	5.0	5.0	5.0		5.0	5.0	5.0	5.0	5.0	5.0
Lane Grp Cap (vph)	480	2582	830	180	1657		273	480	364	266	466	386
v/s Ratio Prot	c0.24	0.33		0.01	0.23			0.09			0.10	
v/s Ratio Perm	c0.44		0.10	0.10			0.17		0.01	0.04		c0.20
v/c Ratio	1.10	0.61	0.19	0.26	0.62		0.63	0.33	0.05	0.17	0.39	0.77
Uniform Delay, d1	28.0	18.8	14.0	20.0	30.5		39.1	35.7	33.1	34.1	36.3	40.9
Progression Factor	1.00	1.00	1.00	1.32	1.15		1.00	1.00	1.00	1.00	1.00	1.00
Incremental Delay, d2	71.1	1.1	0.5	1.5	1.7		6.5	0.9	0.1	0.6	1.1	10.4
Delay (s)	99.1	19.9	14.5	28.0	36.6		45.7	36.6	33.2	34.7	37.4	51.3
Level of Service	F	B	B	C	D		D	D	C	C	D	D
Approach Delay (s)		36.8			36.2			39.9			46.5	
Approach LOS		D			D			D			D	
<b>Intersection Summary</b>												
HCM 2000 Control Delay			38.4			HCM 2000 Level of Service				D		
HCM 2000 Volume to Capacity ratio			1.03									
Actuated Cycle Length (s)			120.0			Sum of lost time (s)			16.8			
Intersection Capacity Utilization			91.0%			ICU Level of Service			E			
Analysis Period (min)			15									

c Critical Lane Group

# HCM Signalized Intersection Capacity Analysis 2027 Future Background Conditions (Mitigation)

## 102: Dixie Rd & Mayfield Rd

























AM Peak Hour

Movement	EBL	EBT	EBR	WBL	WBT	WBR	NBL	NBT	NBR	SBL	SBT	SBR
Lane Configurations												
Traffic Volume (vph)	528	1569	287	47	951	85	173	159	72	44	180	452
Future Volume (vph)	528	1569	287	47	951	85	173	159	72	44	180	452
Ideal Flow (vphpl)	1900	1900	1900	1900	1900	1900	1900	1900	1900	1900	1900	1900
Lane Width	3.5	3.7	3.5	3.5	3.7	3.5	3.5	3.7	3.5	3.5	3.7	3.5
Total Lost time (s)	3.0	6.9	6.9	3.0	6.9		6.9	6.9	6.9	6.9	6.9	6.9
Lane Util. Factor	1.00	0.91	1.00	1.00	0.91		1.00	1.00	1.00	1.00	1.00	1.00
Frbp, ped/bikes	1.00	1.00	0.98	1.00	1.00		1.00	1.00	1.00	1.00	1.00	0.99
Flpb, ped/bikes	1.00	1.00	1.00	1.00	1.00		1.00	1.00	1.00	1.00	1.00	1.00
Frt	1.00	1.00	0.85	1.00	0.99		1.00	1.00	0.85	1.00	1.00	0.85
Flt Protected	0.95	1.00	1.00	0.95	1.00		0.95	1.00	1.00	0.95	1.00	1.00
Satd. Flow (prot)	1623	4768	1533	1566	4411		1698	1830	1389	1552	1779	1472
Flt Permitted	0.15	1.00	1.00	0.15	1.00		0.54	1.00	1.00	0.59	1.00	1.00
Satd. Flow (perm)	256	4768	1533	248	4411		973	1830	1389	961	1779	1472
Peak-hour factor, PHF	1.00	1.00	1.00	1.00	1.00	1.00	1.00	1.00	1.00	1.00	1.00	1.00
Adj. Flow (vph)	528	1569	287	47	951	85	173	159	72	44	180	452
RTOR Reduction (vph)	0	0	116	0	8	0	0	0	56	0	0	311
Lane Group Flow (vph)	528	1569	171	47	1028	0	173	159	16	44	180	141
Confl. Peds. (#/hr)							2					2
Confl. Bikes (#/hr)			1									
Heavy Vehicles (%)	10%	10%	2%	14%	18%	11%	5%	5%	15%	15%	8%	7%
Turn Type	pm+pt	NA	Perm	pm+pt	NA		Perm	NA	Perm	Perm	NA	Perm
Protected Phases	5	2		1	6			4			8	
Permitted Phases	2		2	6			4		4	8		8
Actuated Green, G (s)	87.8	77.5	77.5	49.5	42.2		28.4	28.4	28.4	28.4	28.4	28.4
Effective Green, g (s)	87.8	77.5	77.5	49.5	42.2		28.4	28.4	28.4	28.4	28.4	28.4
Actuated g/C Ratio	0.68	0.60	0.60	0.38	0.32		0.22	0.22	0.22	0.22	0.22	0.22
Clearance Time (s)	3.0	6.9	6.9	3.0	6.9		6.9	6.9	6.9	6.9	6.9	6.9
Vehicle Extension (s)	5.0	5.0	5.0	5.0	5.0		5.0	5.0	5.0	5.0	5.0	5.0
Lane Grp Cap (vph)	620	2842	913	168	1431		212	399	303	209	388	321
v/s Ratio Prot	c0.28	0.33		0.02	0.23			0.09			0.10	
v/s Ratio Perm	c0.30		0.11	0.09			c0.18		0.01	0.05		0.10
v/c Ratio	0.85	0.55	0.19	0.28	0.72		0.82	0.40	0.05	0.21	0.46	0.44
Uniform Delay, d1	28.1	15.8	11.9	25.7	38.7		48.3	43.5	40.2	41.6	44.2	43.9
Progression Factor	1.00	1.00	1.00	1.00	1.00		1.00	1.00	1.00	1.00	1.00	1.00
Incremental Delay, d2	11.9	0.8	0.5	1.9	3.1		23.3	1.4	0.1	1.1	1.8	2.0
Delay (s)	39.9	16.6	12.4	27.6	41.8		71.6	44.9	40.3	42.7	46.0	45.9
Level of Service	D	B	B	C	D		E	D	D	D	D	D
Approach Delay (s)		21.2			41.2			55.5			45.7	
Approach LOS		C			D			E			D	
<b>Intersection Summary</b>												
HCM 2000 Control Delay			32.7			HCM 2000 Level of Service			C			
HCM 2000 Volume to Capacity ratio			0.86									
Actuated Cycle Length (s)			130.0			Sum of lost time (s)			16.8			
Intersection Capacity Utilization			91.0%			ICU Level of Service			E			
Analysis Period (min)			15									

c Critical Lane Group

























HCM Signalized Intersection Capacity Analysis  
 104: Mayfield Rd & 12035 Dixie Rd Development Access

2027 Future Background Conditions  
 AM Peak Hour

												
Movement	EBL	EBT	EBR	WBL	WBT	WBR	NBL	NBT	NBR	SBL	SBT	SBR
Lane Configurations		  			 			 			 	
Traffic Volume (vph)	98	1587	0	0	1048	26	0	0	0	3	0	35
Future Volume (vph)	98	1587	0	0	1048	26	0	0	0	3	0	35
Ideal Flow (vphpl)	1900	1900	1900	1900	1900	1900	1900	1900	1900	1900	1900	1900
Lane Width	3.5	3.7	3.5	3.5	3.7	3.5	3.5	3.7	3.5	3.5	3.7	3.5
Total Lost time (s)	6.9	6.9			6.9						6.9	
Lane Util. Factor	1.00	0.91			0.95						1.00	
Fr <sub>t</sub>	1.00	1.00			1.00						0.88	
Fl <sub>t</sub> Protected	0.95	1.00			1.00						1.00	
Satd. Flow (prot)	1785	4768			3119						1676	
Fl <sub>t</sub> Permitted	0.26	1.00			1.00						0.97	
Satd. Flow (perm)	491	4768			3119						1634	
Peak-hour factor, PHF	1.00	1.00	1.00	1.00	1.00	1.00	1.00	1.00	1.00	1.00	1.00	1.00
Adj. Flow (vph)	98	1587	0	0	1048	26	0	0	0	3	0	35
RTOR Reduction (vph)	0	0	0	0	0	0	0	0	0	0	33	0
Lane Group Flow (vph)	98	1587	0	0	1074	0	0	0	0	0	5	0
Heavy Vehicles (%)	0%	10%	0%	0%	17%	0%	0%	0%	0%	0%	0%	0%
Turn Type	Perm	NA	Perm	Perm	NA					Perm	NA	
Protected Phases		2			6			8			4	
Permitted Phases	2		2	6			8			4		
Actuated Green, G (s)	100.7	100.7			100.7						5.5	
Effective Green, g (s)	100.7	100.7			100.7						5.5	
Actuated g/C Ratio	0.84	0.84			0.84						0.05	
Clearance Time (s)	6.9	6.9			6.9						6.9	
Vehicle Extension (s)	5.0	5.0			5.0						5.0	
Lane Grp Cap (vph)	412	4001			2617						74	
v/s Ratio Prot		0.33			c0.34							
v/s Ratio Perm	0.20										c0.00	
v/c Ratio	0.24	0.40			0.41						0.06	
Uniform Delay, d <sub>1</sub>	1.9	2.3			2.4						54.8	
Progression Factor	4.01	4.02			1.00						1.00	
Incremental Delay, d <sub>2</sub>	1.1	0.2			0.5						0.7	
Delay (s)	8.9	9.6			2.8						55.5	
Level of Service	A	A			A						E	
Approach Delay (s)		9.5			2.8			0.0			55.5	
Approach LOS		A			A			A			E	
<b>Intersection Summary</b>												
HCM 2000 Control Delay			7.6		HCM 2000 Level of Service					A		
HCM 2000 Volume to Capacity ratio			0.39									
Actuated Cycle Length (s)			120.0		Sum of lost time (s)					13.8		
Intersection Capacity Utilization			64.6%		ICU Level of Service					C		
Analysis Period (min)			15									
c Critical Lane Group												

HCM Signalized Intersection Capacity Analysis  
101: Bramalea Rd & Mayfield Rd

2027 Future Background Conditions  
PM Peak Hour

													
Movement	EBL	EBT	EBR	WBL	WBT	WBR	NBL	NBT	NBR	SBL	SBT	SBR	
Lane Configurations													
Traffic Volume (vph)	144	974	146	121	1040	25	265	176	61	27	107	91	
Future Volume (vph)	144	974	146	121	1040	25	265	176	61	27	107	91	
Ideal Flow (vphpl)	1900	1900	1900	1900	1900	1900	1900	1900	1900	1900	1900	1900	
Lane Width	3.5	3.7	3.5	3.5	3.7	3.5	3.5	3.7	3.5	3.5	3.7	3.5	
Total Lost time (s)	3.0	7.2	7.2	7.2	7.2	7.2	7.1	7.1	7.1	3.0	7.1		
Lane Util. Factor	1.00	0.91	1.00	1.00	0.91	1.00	1.00	1.00	1.00	1.00	0.95		
Frbp, ped/bikes	1.00	1.00	0.99	1.00	1.00	0.97	1.00	1.00	0.99	1.00	0.99		
Flpb, ped/bikes	1.00	1.00	1.00	1.00	1.00	1.00	1.00	1.00	1.00	1.00	1.00		
Frt	1.00	1.00	0.85	1.00	1.00	0.85	1.00	1.00	0.85	1.00	0.93		
Flt Protected	0.95	1.00	1.00	0.95	1.00	1.00	0.95	1.00	1.00	0.95	1.00		
Satd. Flow (prot)	1767	4683	1545	1784	4856	1480	1766	1921	1577	1785	3285		
Flt Permitted	0.20	1.00	1.00	0.28	1.00	1.00	0.63	1.00	1.00	0.56	1.00		
Satd. Flow (perm)	374	4683	1545	529	4856	1480	1166	1921	1577	1047	3285		
Peak-hour factor, PHF	1.00	1.00	1.00	1.00	1.00	1.00	1.00	1.00	1.00	1.00	1.00	1.00	
Adj. Flow (vph)	144	974	146	121	1040	25	265	176	61	27	107	91	
RTOR Reduction (vph)	0	0	68	0	0	14	0	0	44	0	60	0	
Lane Group Flow (vph)	144	974	78	121	1040	11	265	176	17	27	138	0	
Confl. Peds. (#/hr)	6		2	2		6	1					1	
Confl. Bikes (#/hr)									1				
Heavy Vehicles (%)	1%	12%	2%	0%	8%	5%	1%	0%	0%	0%	1%	5%	
Turn Type	pm+pt	NA	Perm	Perm	NA	Perm	Perm	NA	Perm	pm+pt	NA		
Protected Phases	5	2			6			4		3	8		
Permitted Phases	2		2	6		6	4		4	8			
Actuated Green, G (s)	63.1	63.1	63.1	53.0	53.0	53.0	33.5	33.5	33.5	40.3	40.3		
Effective Green, g (s)	63.1	63.1	63.1	53.0	53.0	53.0	33.5	33.5	33.5	40.3	40.3		
Actuated g/C Ratio	0.54	0.54	0.54	0.45	0.45	0.45	0.28	0.28	0.28	0.34	0.34		
Clearance Time (s)	3.0	7.2	7.2	7.2	7.2	7.2	7.1	7.1	7.1	3.0	7.1		
Vehicle Extension (s)	5.0	5.0	5.0	5.0	5.0	5.0	5.0	5.0	5.0	5.0	5.0		
Lane Grp Cap (vph)	284	2510	828	238	2186	666	331	546	448	382	1124		
v/s Ratio Prot	c0.03	0.21			0.21			0.09		0.00	c0.04		
v/s Ratio Perm	c0.24		0.05	0.23		0.01	c0.23		0.01	0.02			
v/c Ratio	0.51	0.39	0.09	0.51	0.48	0.02	0.80	0.32	0.04	0.07	0.12		
Uniform Delay, d1	14.8	16.0	13.3	23.1	22.6	17.9	39.0	33.2	30.5	25.9	26.6		
Progression Factor	1.00	1.00	1.00	1.00	1.00	1.00	1.00	1.00	1.00	1.00	1.00		
Incremental Delay, d2	3.0	0.5	0.2	7.6	0.7	0.0	14.6	0.7	0.1	0.2	0.1		
Delay (s)	17.8	16.4	13.6	30.6	23.4	18.0	53.6	33.9	30.5	26.1	26.7		
Level of Service	B	B	B	C	C	B	D	C	C	C	C		
Approach Delay (s)		16.3			24.0			43.9			26.6		
Approach LOS		B			C			D			C		
<b>Intersection Summary</b>													
HCM 2000 Control Delay			24.3	HCM 2000 Level of Service						C			
HCM 2000 Volume to Capacity ratio			0.61										
Actuated Cycle Length (s)			117.7	Sum of lost time (s)						20.3			
Intersection Capacity Utilization			99.7%	ICU Level of Service						F			
Analysis Period (min)			15										

c Critical Lane Group

HCM Signalized Intersection Capacity Analysis  
102: Dixie Rd & Mayfield Rd

2027 Future Background Conditions  
PM Peak Hour

Movement	EBL	EBT	EBR	WBL	WBT	WBR	NBL	NBT	NBR	SBL	SBT	SBR
Lane Configurations												
Traffic Volume (vph)	508	1392	248	86	1554	65	232	235	64	77	196	623
Future Volume (vph)	508	1392	248	86	1554	65	232	235	64	77	196	623
Ideal Flow (vphpl)	1900	1900	1900	1900	1900	1900	1900	1900	1900	1900	1900	1900
Lane Width	3.5	3.7	3.5	3.5	3.7	3.5	3.5	3.7	3.5	3.5	3.7	3.5
Total Lost time (s)	3.0	6.9	6.9	3.0	6.9		6.9	6.9	6.9	6.9	6.9	6.9
Lane Util. Factor	1.00	0.91	1.00	1.00	0.91		1.00	1.00	1.00	1.00	1.00	1.00
Frbp, ped/bikes	1.00	1.00	1.00	1.00	1.00		1.00	1.00	0.99	1.00	1.00	0.98
Flpb, ped/bikes	1.00	1.00	1.00	1.00	1.00		1.00	1.00	1.00	1.00	1.00	1.00
Frt	1.00	1.00	0.85	1.00	0.99		1.00	1.00	0.85	1.00	1.00	0.85
Flt Protected	0.95	1.00	1.00	0.95	1.00		0.95	1.00	1.00	0.95	1.00	1.00
Satd. Flow (prot)	1580	4683	1581	1684	4847		1763	1865	1432	1698	1883	1440
Flt Permitted	0.09	1.00	1.00	0.17	1.00		0.59	1.00	1.00	0.54	1.00	1.00
Satd. Flow (perm)	154	4683	1581	306	4847		1097	1865	1432	961	1883	1440
Peak-hour factor, PHF	1.00	1.00	1.00	1.00	1.00	1.00	1.00	1.00	1.00	1.00	1.00	1.00
Adj. Flow (vph)	508	1392	248	86	1554	65	232	235	64	77	196	623
RTOR Reduction (vph)	0	0	132	0	4	0	0	0	42	0	0	187
Lane Group Flow (vph)	508	1392	116	86	1615	0	232	235	22	77	196	436
Confl. Peds. (#/hr)	5					5	4		2	2		4
Confl. Bikes (#/hr)												3
Heavy Vehicles (%)	13%	12%	1%	6%	7%	18%	1%	3%	10%	5%	2%	9%
Turn Type	pm+pt	NA	Perm	pm+pt	NA		Perm	NA	Perm	Perm	NA	Perm
Protected Phases	5	2		1	6			4			8	
Permitted Phases	2		2	6			4		4	8		8
Actuated Green, G (s)	65.4	56.3	56.3	46.2	40.1		40.8	40.8	40.8	40.8	40.8	40.8
Effective Green, g (s)	65.4	56.3	56.3	46.2	40.1		40.8	40.8	40.8	40.8	40.8	40.8
Actuated g/C Ratio	0.55	0.47	0.47	0.39	0.33		0.34	0.34	0.34	0.34	0.34	0.34
Clearance Time (s)	3.0	6.9	6.9	3.0	6.9		6.9	6.9	6.9	6.9	6.9	6.9
Vehicle Extension (s)	5.0	5.0	5.0	5.0	5.0		5.0	5.0	5.0	5.0	5.0	5.0
Lane Grp Cap (vph)	348	2197	741	187	1619		372	634	486	326	640	489
v/s Ratio Prot	c0.27	0.30		0.02	0.33			0.13			0.10	
v/s Ratio Perm	c0.52		0.07	0.15			0.21		0.02	0.08		c0.30
v/c Ratio	1.46	0.63	0.16	0.46	1.00		0.62	0.37	0.04	0.24	0.31	0.89
Uniform Delay, d1	37.7	24.1	18.3	23.9	39.9		33.2	29.9	26.5	28.4	29.2	37.5
Progression Factor	1.00	1.00	1.00	0.65	0.88		1.00	1.00	1.00	1.00	1.00	1.00
Incremental Delay, d2	222.2	1.4	0.5	3.0	19.6		4.6	0.8	0.1	0.8	0.6	19.3
Delay (s)	259.9	25.5	18.7	18.5	54.7		37.7	30.7	26.6	29.2	29.7	56.8
Level of Service	F	C	B	B	D		D	C	C	C	C	E
Approach Delay (s)		80.1			52.9			33.3			48.5	
Approach LOS		F			D			C			D	
<b>Intersection Summary</b>												
HCM 2000 Control Delay			61.3			HCM 2000 Level of Service			E			
HCM 2000 Volume to Capacity ratio			1.27									
Actuated Cycle Length (s)			120.0			Sum of lost time (s)			16.8			
Intersection Capacity Utilization			110.3%			ICU Level of Service			H			
Analysis Period (min)			15									

c Critical Lane Group

# HCM Signalized Intersection Capacity Analysis 2027 Future Background Conditions (Mitigation)

102: Dixie Rd & Mayfield Rd

























PM Peak Hour

Movement	EBL	EBT	EBR	WBL	WBT	WBR	NBL	NBT	NBR	SBL	SBT	SBR
Lane Configurations												
Traffic Volume (vph)	508	1392	248	86	1554	65	232	235	64	77	196	623
Future Volume (vph)	508	1392	248	86	1554	65	232	235	64	77	196	623
Ideal Flow (vphpl)	1900	1900	1900	1900	1900	1900	1900	1900	1900	1900	1900	1900
Lane Width	3.5	3.7	3.5	3.5	3.7	3.5	3.5	3.7	3.5	3.5	3.7	3.5
Total Lost time (s)	3.0	6.9	6.9	3.0	6.9		6.9	6.9	6.9	6.9	6.9	6.9
Lane Util. Factor	1.00	0.91	1.00	1.00	0.91		1.00	1.00	1.00	1.00	1.00	1.00
Frbp, ped/bikes	1.00	1.00	1.00	1.00	1.00		1.00	1.00	0.99	1.00	1.00	0.98
Flpb, ped/bikes	1.00	1.00	1.00	1.00	1.00		1.00	1.00	1.00	1.00	1.00	1.00
Frt	1.00	1.00	0.85	1.00	0.99		1.00	1.00	0.85	1.00	1.00	0.85
Flt Protected	0.95	1.00	1.00	0.95	1.00		0.95	1.00	1.00	0.95	1.00	1.00
Satd. Flow (prot)	1580	4683	1581	1684	4846		1762	1865	1432	1698	1883	1438
Flt Permitted	0.08	1.00	1.00	0.18	1.00		0.53	1.00	1.00	0.46	1.00	1.00
Satd. Flow (perm)	126	4683	1581	322	4846		979	1865	1432	824	1883	1438
Peak-hour factor, PHF	1.00	1.00	1.00	1.00	1.00	1.00	1.00	1.00	1.00	1.00	1.00	1.00
Adj. Flow (vph)	508	1392	248	86	1554	65	232	235	64	77	196	623
RTOR Reduction (vph)	0	0	108	0	3	0	0	0	47	0	0	333
Lane Group Flow (vph)	508	1392	140	86	1616	0	232	235	17	77	196	290
Confl. Peds. (#/hr)	5					5	4		2	2		4
Confl. Bikes (#/hr)												3
Heavy Vehicles (%)	13%	12%	1%	6%	7%	18%	1%	3%	10%	5%	2%	9%
Turn Type	pm+pt	NA	Perm	pm+pt	NA		Perm	NA	Perm	Perm	NA	Perm
Protected Phases	5	2		1	6			4			8	
Permitted Phases	2		2	6			4		4	8		8
Actuated Green, G (s)	96.9	84.8	84.8	59.0	49.9		39.3	39.3	39.3	39.3	39.3	39.3
Effective Green, g (s)	96.9	84.8	84.8	59.0	49.9		39.3	39.3	39.3	39.3	39.3	39.3
Actuated g/C Ratio	0.65	0.57	0.57	0.39	0.33		0.26	0.26	0.26	0.26	0.26	0.26
Clearance Time (s)	3.0	6.9	6.9	3.0	6.9		6.9	6.9	6.9	6.9	6.9	6.9
Vehicle Extension (s)	5.0	5.0	5.0	5.0	5.0		5.0	5.0	5.0	5.0	5.0	5.0
Lane Grp Cap (vph)	507	2647	893	209	1612		256	488	375	215	493	376
v/s Ratio Prot	c0.29	0.30		0.02	0.33			0.13			0.10	
v/s Ratio Perm	c0.35		0.09	0.14			c0.24		0.01	0.09		0.20
v/c Ratio	1.00	0.53	0.16	0.41	1.00		0.91	0.48	0.04	0.36	0.40	0.77
Uniform Delay, d1	46.1	20.2	15.6	29.1	50.0		53.6	46.7	41.3	45.1	45.6	51.2
Progression Factor	1.00	1.00	1.00	1.00	1.00		1.00	1.00	1.00	1.00	1.00	1.00
Incremental Delay, d2	40.5	0.8	0.4	2.7	23.1		33.9	1.6	0.1	2.1	1.1	11.0
Delay (s)	86.5	20.9	15.9	31.8	73.1		87.5	48.3	41.4	47.2	46.7	62.2
Level of Service	F	C	B	C	E		F	D	D	D	D	E
Approach Delay (s)		35.9			71.0			64.6			57.5	
Approach LOS		D			E			E			E	
<b>Intersection Summary</b>												
HCM 2000 Control Delay			53.8			HCM 2000 Level of Service			D			
HCM 2000 Volume to Capacity ratio			0.99									
Actuated Cycle Length (s)			150.0			Sum of lost time (s)			16.8			
Intersection Capacity Utilization			110.3%			ICU Level of Service			H			
Analysis Period (min)			15									

c Critical Lane Group

HCM Signalized Intersection Capacity Analysis  
 104: Mayfield Rd & 12035 Dixie Rd Development Access

2027 Future Background Conditions  
 PM Peak Hour

													
Movement	EBL	EBT	EBR	WBL	WBT	WBR	NBL	NBT	NBR	SBL	SBT	SBR	
Lane Configurations		  			 			 			 		
Traffic Volume (vph)	43	1491	0	0	1601	3	0	0	0	27	0	104	
Future Volume (vph)	43	1491	0	0	1601	3	0	0	0	27	0	104	
Ideal Flow (vphpl)	1900	1900	1900	1900	1900	1900	1900	1900	1900	1900	1900	1900	
Lane Width	3.5	3.7	3.5	3.5	3.7	3.5	3.5	3.7	3.5	3.5	3.7	3.5	
Total Lost time (s)	6.9	6.9			6.9							6.9	
Lane Util. Factor	1.00	0.91			0.95							1.00	
Frt	1.00	1.00			1.00							0.89	
Flt Protected	0.95	1.00			1.00							0.99	
Satd. Flow (prot)	1785	4683			3411							1698	
Flt Permitted	0.13	1.00			1.00							0.93	
Satd. Flow (perm)	235	4683			3411							1592	
Peak-hour factor, PHF	1.00	1.00	1.00	1.00	1.00	1.00	1.00	1.00	1.00	1.00	1.00	1.00	
Adj. Flow (vph)	43	1491	0	0	1601	3	0	0	0	27	0	104	
RTOR Reduction (vph)	0	0	0	0	0	0	0	0	0	0	31	0	
Lane Group Flow (vph)	43	1491	0	0	1604	0	0	0	0	0	100	0	
Heavy Vehicles (%)	0%	12%	0%	0%	7%	0%	0%	0%	0%	0%	0%	0%	
Turn Type	Perm	NA	Perm	Perm	NA						Perm	NA	
Protected Phases		2			6			8				4	
Permitted Phases	2		2	6			8			4			
Actuated Green, G (s)	91.7	91.7			91.7							14.5	
Effective Green, g (s)	91.7	91.7			91.7							14.5	
Actuated g/C Ratio	0.76	0.76			0.76							0.12	
Clearance Time (s)	6.9	6.9			6.9							6.9	
Vehicle Extension (s)	5.0	5.0			5.0							5.0	
Lane Grp Cap (vph)	179	3578			2606							192	
v/s Ratio Prot		0.32			c0.47								
v/s Ratio Perm	0.18											c0.06	
v/c Ratio	0.24	0.42			0.62							0.52	
Uniform Delay, d1	4.1	4.9			6.3							49.5	
Progression Factor	1.80	1.59			1.00							1.00	
Incremental Delay, d2	2.6	0.3			1.1							4.8	
Delay (s)	9.9	8.1			7.4							54.3	
Level of Service	A	A			A							D	
Approach Delay (s)		8.1			7.4			0.0				54.3	
Approach LOS		A			A			A				D	
<b>Intersection Summary</b>													
HCM 2000 Control Delay			9.6									HCM 2000 Level of Service	A
HCM 2000 Volume to Capacity ratio			0.60										
Actuated Cycle Length (s)			120.0									Sum of lost time (s)	13.8
Intersection Capacity Utilization			63.8%									ICU Level of Service	B
Analysis Period (min)			15										

c Critical Lane Group

Queues  
101: Bramalea Rd & Mayfield Rd

2027 Future Background Conditions  
AM Peak Hour



Lane Group	EBL	EBT	EBR	WBL	WBT	WBR	NBL	NBT	NBR	SBL	SBT
Lane Group Flow (vph)	289	1070	222	112	763	25	68	147	61	49	375
v/c Ratio	0.60	0.37	0.22	0.50	0.33	0.04	0.47	0.52	0.21	0.17	0.42
Control Delay	14.1	10.4	1.9	27.2	15.0	0.1	50.3	46.1	6.7	27.4	18.6
Queue Delay	0.0	0.0	0.0	0.0	0.0	0.0	0.0	0.0	0.0	0.0	0.0
Total Delay	14.1	10.4	1.9	27.2	15.0	0.1	50.3	46.1	6.7	27.4	18.6
Queue Length 50th (m)	19.6	33.0	0.0	12.8	28.4	0.0	11.4	25.0	0.0	6.5	16.2
Queue Length 95th (m)	36.5	48.1	8.8	33.6	41.4	0.0	23.8	42.3	6.6	14.3	27.5
Internal Link Dist (m)		182.8			347.4			479.0			343.8
Turn Bay Length (m)	180.0		110.0	80.0		100.0	100.0			110.0	
Base Capacity (vph)	485	2925	1029	225	2329	644	486	949	771	293	2129
Starvation Cap Reductn	0	0	0	0	0	0	0	0	0	0	0
Spillback Cap Reductn	0	0	0	0	0	0	0	0	0	0	0
Storage Cap Reductn	0	0	0	0	0	0	0	0	0	0	0
Reduced v/c Ratio	0.60	0.37	0.22	0.50	0.33	0.04	0.14	0.15	0.08	0.17	0.18

Intersection Summary

Queues  
102: Dixie Rd & Mayfield Rd

2027 Future Background Conditions  
AM Peak Hour



Lane Group	EBL	EBT	EBR	WBL	WBT	NBL	NBT	NBR	SBL	SBT	SBR
Lane Group Flow (vph)	528	1569	287	47	1036	173	159	72	44	180	452
v/c Ratio	1.08	0.60	0.30	0.23	0.62	0.63	0.33	0.17	0.17	0.39	0.83
Control Delay	90.1	22.3	3.3	18.0	36.4	47.5	35.1	4.0	30.9	36.4	34.4
Queue Delay	0.0	0.0	0.0	0.0	0.0	0.0	0.0	0.0	0.0	0.0	0.0
Total Delay	90.1	22.3	3.3	18.0	36.4	47.5	35.1	4.0	30.9	36.4	34.4
Queue Length 50th (m)	~98.8	85.6	0.0	4.8	76.7	33.1	27.8	0.0	7.3	32.0	52.1
Queue Length 95th (m)	#205.1	123.9	14.6	13.1	91.1	46.4	37.5	5.9	13.7	42.2	76.3
Internal Link Dist (m)		507.8			328.1		418.0			489.9	
Turn Bay Length (m)	170.0		100.0	150.0		120.0		50.0	80.0		170.0
Base Capacity (vph)	490	2607	968	208	1667	401	703	589	389	683	695
Starvation Cap Reductn	0	0	0	0	0	0	0	0	0	0	0
Spillback Cap Reductn	0	0	0	0	0	0	0	0	0	0	0
Storage Cap Reductn	0	0	0	0	0	0	0	0	0	0	0
Reduced v/c Ratio	1.08	0.60	0.30	0.23	0.62	0.43	0.23	0.12	0.11	0.26	0.65

Intersection Summary

~ Volume exceeds capacity, queue is theoretically infinite.

Queue shown is maximum after two cycles.

# 95th percentile volume exceeds capacity, queue may be longer.

Queue shown is maximum after two cycles.

Queues  
102: Dixie Rd & Mayfield Rd

2027 Future Background Conditions (Mitigation)  
AM Peak Hour



Lane Group	EBL	EBT	EBR	WBL	WBT	NBL	NBT	NBR	SBL	SBT	SBR
Lane Group Flow (vph)	528	1569	287	47	1036	173	159	72	44	180	452
v/c Ratio	0.84	0.55	0.28	0.24	0.72	0.82	0.40	0.20	0.21	0.46	0.72
Control Delay	40.2	18.4	2.6	15.8	41.6	75.2	44.6	6.5	40.6	46.5	13.2
Queue Delay	0.0	0.0	0.0	0.0	0.0	0.0	0.0	0.0	0.0	0.0	0.0
Total Delay	40.2	18.4	2.6	15.8	41.6	75.2	44.6	6.5	40.6	46.5	13.2
Queue Length 50th (m)	87.0	78.9	0.0	3.0	77.9	39.3	32.5	0.0	8.6	37.4	10.5
Queue Length 95th (m)	#178.3	117.3	13.3	8.6	93.2	57.5	45.4	8.2	16.5	51.2	39.0
Internal Link Dist (m)		507.8			328.1		418.0			489.9	
Turn Bay Length (m)	170.0		100.0	150.0		120.0		50.0	80.0		170.0
Base Capacity (vph)	628	2864	1035	194	1440	336	633	535	332	615	769
Starvation Cap Reductn	0	0	0	0	0	0	0	0	0	0	0
Spillback Cap Reductn	0	0	0	0	0	0	0	0	0	0	0
Storage Cap Reductn	0	0	0	0	0	0	0	0	0	0	0
Reduced v/c Ratio	0.84	0.55	0.28	0.24	0.72	0.51	0.25	0.13	0.13	0.29	0.59

Intersection Summary

# 95th percentile volume exceeds capacity, queue may be longer.  
Queue shown is maximum after two cycles.

## Queues

2027 Future Background Conditions

104: Mayfield Rd &amp; 12035 Dixie Rd Development Access

AM Peak Hour



Lane Group	EBL	EBT	WBT	SBT
Lane Group Flow (vph)	98	1587	1074	38
v/c Ratio	0.23	0.38	0.39	0.25
Control Delay	11.2	9.3	2.8	22.5
Queue Delay	0.0	0.0	0.0	0.0
Total Delay	11.2	9.3	2.8	22.5
Queue Length 50th (m)	7.8	55.4	26.4	0.6
Queue Length 95th (m)	m31.2	125.6	38.4	10.4
Internal Link Dist (m)		328.1	608.7	157.9
Turn Bay Length (m)	50.0			
Base Capacity (vph)	433	4219	2760	635
Starvation Cap Reductn	0	0	0	0
Spillback Cap Reductn	0	0	0	0
Storage Cap Reductn	0	0	0	0
Reduced v/c Ratio	0.23	0.38	0.39	0.06

## Intersection Summary

m Volume for 95th percentile queue is metered by upstream signal.

Queues  
101: Bramalea Rd & Mayfield Rd

2027 Future Background Conditions  
PM Peak Hour



Lane Group	EBL	EBT	EBR	WBL	WBT	WBR	NBL	NBT	NBR	SBL	SBT
Lane Group Flow (vph)	144	974	146	121	1040	25	265	176	61	27	198
v/c Ratio	0.48	0.38	0.16	0.50	0.47	0.04	0.79	0.32	0.12	0.06	0.17
Control Delay	21.1	18.4	3.6	37.1	25.4	0.1	55.8	33.7	3.6	21.2	13.2
Queue Delay	0.0	0.0	0.0	0.0	0.0	0.0	0.0	0.0	0.0	0.0	0.0
Total Delay	21.1	18.4	3.6	37.1	25.4	0.1	55.8	33.7	3.6	21.2	13.2
Queue Length 50th (m)	14.9	46.3	0.0	19.2	59.3	0.0	53.5	30.3	0.0	3.5	7.9
Queue Length 95th (m)	32.0	72.0	10.9	46.8	88.2	0.0	82.0	46.8	5.3	8.5	14.8
Internal Link Dist (m)		182.8			347.4			479.0			343.8
Turn Bay Length (m)	180.0		110.0	80.0		100.0	100.0			110.0	
Base Capacity (vph)	300	2533	902	240	2203	714	518	854	746	432	1791
Starvation Cap Reductn	0	0	0	0	0	0	0	0	0	0	0
Spillback Cap Reductn	0	0	0	0	0	0	0	0	0	0	0
Storage Cap Reductn	0	0	0	0	0	0	0	0	0	0	0
Reduced v/c Ratio	0.48	0.38	0.16	0.50	0.47	0.04	0.51	0.21	0.08	0.06	0.11

Intersection Summary

Queues  
102: Dixie Rd & Mayfield Rd

2027 Future Background Conditions  
PM Peak Hour



Lane Group	EBL	EBT	EBR	WBL	WBT	NBL	NBT	NBR	SBL	SBT	SBR
Lane Group Flow (vph)	508	1392	248	86	1619	232	235	64	77	196	623
v/c Ratio	1.44	0.63	0.28	0.39	1.00	0.62	0.37	0.12	0.24	0.31	0.92
Control Delay	241.6	27.0	3.6	13.7	55.1	40.0	30.5	2.6	28.3	29.2	40.0
Queue Delay	0.0	0.0	0.0	0.0	0.0	0.0	0.0	0.0	0.0	0.0	0.0
Total Delay	241.6	27.0	3.6	13.7	55.1	40.0	30.5	2.6	28.3	29.2	40.0
Queue Length 50th (m)	~152.0	90.1	0.0	9.0	128.3	39.0	35.6	0.0	11.1	29.0	73.6
Queue Length 95th (m)	#213.2	106.0	13.7	m10.3	#161.1	62.9	54.1	4.3	21.7	45.3	#139.8
Internal Link Dist (m)		507.8			328.1		418.0			489.9	
Turn Bay Length (m)	170.0		100.0	150.0		120.0		50.0	80.0		170.0
Base Capacity (vph)	353	2219	879	219	1623	421	716	605	368	723	727
Starvation Cap Reductn	0	0	0	0	0	0	0	0	0	0	0
Spillback Cap Reductn	0	0	0	0	0	0	0	0	0	0	0
Storage Cap Reductn	0	0	0	0	0	0	0	0	0	0	0
Reduced v/c Ratio	1.44	0.63	0.28	0.39	1.00	0.55	0.33	0.11	0.21	0.27	0.86

Intersection Summary

~ Volume exceeds capacity, queue is theoretically infinite.

Queue shown is maximum after two cycles.

# 95th percentile volume exceeds capacity, queue may be longer.

Queue shown is maximum after two cycles.

m Volume for 95th percentile queue is metered by upstream signal.

Queues  
102: Dixie Rd & Mayfield Rd

2027 Future Background Conditions (Mitigation)  
PM Peak Hour



Lane Group	EBL	EBT	EBR	WBL	WBT	NBL	NBT	NBR	SBL	SBT	SBR
Lane Group Flow (vph)	508	1392	248	86	1619	232	235	64	77	196	623
v/c Ratio	1.00	0.53	0.25	0.40	1.00	0.91	0.48	0.15	0.36	0.40	0.88
Control Delay	81.6	21.9	2.6	21.1	72.5	89.3	49.2	7.2	48.3	46.9	28.2
Queue Delay	0.0	0.0	0.0	0.0	0.0	0.0	0.0	0.0	0.0	0.0	0.0
Total Delay	81.6	21.9	2.6	21.1	72.5	89.3	49.2	7.2	48.3	46.9	28.2
Queue Length 50th (m)	~138.0	89.0	0.0	8.1	~163.2	60.3	53.3	0.0	16.8	43.4	50.9
Queue Length 95th (m)	#212.9	104.7	12.1	15.2	#196.0	#97.8	75.0	8.5	30.4	62.6	104.6
Internal Link Dist (m)		507.8			328.1		418.0			489.9	
Turn Bay Length (m)	170.0		100.0	150.0		120.0		50.0	80.0		170.0
Base Capacity (vph)	510	2647	1001	219	1614	295	563	482	248	568	749
Starvation Cap Reductn	0	0	0	0	0	0	0	0	0	0	0
Spillback Cap Reductn	0	0	0	0	0	0	0	0	0	0	0
Storage Cap Reductn	0	0	0	0	0	0	0	0	0	0	0
Reduced v/c Ratio	1.00	0.53	0.25	0.39	1.00	0.79	0.42	0.13	0.31	0.35	0.83

Intersection Summary

~ Volume exceeds capacity, queue is theoretically infinite.

Queue shown is maximum after two cycles.

# 95th percentile volume exceeds capacity, queue may be longer.

Queue shown is maximum after two cycles.

## Queues

2027 Future Background Conditions

104: Mayfield Rd &amp; 12035 Dixie Rd Development Access

PM Peak Hour



Lane Group	EBL	EBT	WBT	SBT
Lane Group Flow (vph)	43	1491	1604	131
v/c Ratio	0.24	0.42	0.62	0.59
Control Delay	13.2	8.8	8.1	46.2
Queue Delay	0.0	0.0	0.0	0.0
Total Delay	13.2	8.8	8.1	46.2
Queue Length 50th (m)	3.3	42.4	69.2	19.8
Queue Length 95th (m)	m7.6	65.8	106.5	36.4
Internal Link Dist (m)		328.1	608.7	157.9
Turn Bay Length (m)	50.0			
Base Capacity (vph)	179	3577	2606	620
Starvation Cap Reductn	0	0	0	0
Spillback Cap Reductn	0	0	0	0
Storage Cap Reductn	0	0	0	0
Reduced v/c Ratio	0.24	0.42	0.62	0.21

## Intersection Summary

m Volume for 95th percentile queue is metered by upstream signal.

## **Appendix D**

### **Future (2032) Background Intersection Operation Calculations (Synchro)**





























HCM Signalized Intersection Capacity Analysis  
101: Bramalea Rd & Mayfield Rd

2032 Future Background Conditions  
AM Peak Hour

Movement	EBL	EBT	EBR	WBL	WBT	WBR	NBL	NBT	NBR	SBL	SBT	SBR	
Lane Configurations													
Traffic Volume (vph)	343	1269	264	133	895	30	80	175	72	58	251	195	
Future Volume (vph)	343	1269	264	133	895	30	80	175	72	58	251	195	
Ideal Flow (vphpl)	1900	1900	1900	1900	1900	1900	1900	1900	1900	1900	1900	1900	
Lane Width	3.5	3.7	3.5	3.5	3.7	3.5	3.5	3.7	3.5	3.5	3.7	3.5	
Total Lost time (s)	3.0	7.2	7.2	7.2	7.2	7.2	7.1	7.1	7.1	3.0	7.1		
Lane Util. Factor	1.00	0.91	1.00	1.00	0.91	1.00	1.00	1.00	1.00	1.00	0.95		
Frpb, ped/bikes	1.00	1.00	0.99	1.00	1.00	1.00	1.00	1.00	0.98	1.00	1.00		
Flpb, ped/bikes	1.00	1.00	1.00	1.00	1.00	1.00	1.00	1.00	1.00	1.00	1.00		
Frt	1.00	1.00	0.85	1.00	1.00	0.85	1.00	1.00	0.85	1.00	0.93		
Flt Protected	0.95	1.00	1.00	0.95	1.00	1.00	0.95	1.00	1.00	0.95	1.00		
Satd. Flow (prot)	1785	4683	1515	1608	4445	1157	1700	1847	1427	1591	3362		
Flt Permitted	0.27	1.00	1.00	0.21	1.00	1.00	0.49	1.00	1.00	0.48	1.00		
Satd. Flow (perm)	503	4683	1515	350	4445	1157	884	1847	1427	811	3362		
Peak-hour factor, PHF	1.00	1.00	1.00	1.00	1.00	1.00	1.00	1.00	1.00	1.00	1.00	1.00	
Adj. Flow (vph)	343	1269	264	133	895	30	80	175	72	58	251	195	
RTOR Reduction (vph)	0	0	103	0	0	15	0	0	60	0	127	0	
Lane Group Flow (vph)	343	1269	161	133	895	15	80	175	12	58	319	0	
Confl. Peds. (#/hr)			2	2					9	9			
Heavy Vehicles (%)	0%	12%	4%	11%	18%	38%	5%	4%	10%	12%	1%	2%	
Turn Type	pm+pt	NA	Perm	Perm	NA	Perm	Perm	NA	Perm	pm+pt	NA		
Protected Phases	5	2			6			4		3	8		
Permitted Phases	2		2	6		6	4		4	8			
Actuated Green, G (s)	62.4	62.4	62.4	52.4	52.4	52.4	17.2	17.2	17.2	25.6	25.6		
Effective Green, g (s)	62.4	62.4	62.4	52.4	52.4	52.4	17.2	17.2	17.2	25.6	25.6		
Actuated g/C Ratio	0.61	0.61	0.61	0.51	0.51	0.51	0.17	0.17	0.17	0.25	0.25		
Clearance Time (s)	3.0	7.2	7.2	7.2	7.2	7.2	7.1	7.1	7.1	3.0	7.1		
Vehicle Extension (s)	5.0	5.0	5.0	5.0	5.0	5.0	5.0	5.0	5.0	5.0	5.0		
Lane Grp Cap (vph)	394	2856	924	179	2276	592	148	310	239	244	841		
v/s Ratio Prot	c0.06	0.27			0.20			c0.09		0.01	c0.09		
v/s Ratio Perm	c0.47		0.11	0.38		0.01	0.09		0.01	0.05			
v/c Ratio	0.87	0.44	0.17	0.74	0.39	0.03	0.54	0.56	0.05	0.24	0.38		
Uniform Delay, d1	12.6	10.7	8.7	19.6	15.2	12.3	38.9	39.1	35.7	30.0	31.8		
Progression Factor	1.00	1.00	1.00	1.00	1.00	1.00	1.00	1.00	1.00	1.00	1.00		
Incremental Delay, d2	19.8	0.5	0.4	24.1	0.5	0.1	6.9	3.8	0.2	1.1	0.6		
Delay (s)	32.4	11.2	9.1	43.7	15.8	12.4	45.9	42.9	35.9	31.0	32.4		
Level of Service	C	B	A	D	B	B	D	D	D	C	C		
Approach Delay (s)		14.8			19.2			42.1			32.2		
Approach LOS		B			B			D			C		
<b>Intersection Summary</b>													
HCM 2000 Control Delay			20.7		HCM 2000 Level of Service						C		
HCM 2000 Volume to Capacity ratio			0.80										
Actuated Cycle Length (s)			102.3		Sum of lost time (s)						20.3		
Intersection Capacity Utilization			97.0%		ICU Level of Service						F		
Analysis Period (min)			15										
c	Critical Lane Group												

HCM Signalized Intersection Capacity Analysis  
102: Dixie Rd & Mayfield Rd

2032 Future Background Conditions  
AM Peak Hour

												
Movement	EBL	EBT	EBR	WBL	WBT	WBR	NBL	NBT	NBR	SBL	SBT	SBR
Lane Configurations		  			   							
Traffic Volume (vph)	589	1850	341	55	1124	95	206	177	81	52	211	518
Future Volume (vph)	589	1850	341	55	1124	95	206	177	81	52	211	518
Ideal Flow (vphpl)	1900	1900	1900	1900	1900	1900	1900	1900	1900	1900	1900	1900
Lane Width	3.5	3.7	3.5	3.5	3.7	3.5	3.5	3.7	3.5	3.5	3.7	3.5
Total Lost time (s)	3.0	6.9	6.9	3.0	6.9		6.9	6.9	6.9	6.9	6.9	6.9
Lane Util. Factor	1.00	0.91	1.00	1.00	0.91		1.00	1.00	1.00	1.00	1.00	1.00
Frpb, ped/bikes	1.00	1.00	0.98	1.00	1.00		1.00	1.00	1.00	1.00	1.00	0.99
Flpb, ped/bikes	1.00	1.00	1.00	1.00	1.00		1.00	1.00	1.00	1.00	1.00	1.00
Frt	1.00	1.00	0.85	1.00	0.99		1.00	1.00	0.85	1.00	1.00	0.85
Flt Protected	0.95	1.00	1.00	0.95	1.00		0.95	1.00	1.00	0.95	1.00	1.00
Satd. Flow (prot)	1623	4768	1533	1566	4413		1698	1830	1389	1552	1779	1472
Flt Permitted	0.12	1.00	1.00	0.09	1.00		0.56	1.00	1.00	0.61	1.00	1.00
Satd. Flow (perm)	211	4768	1533	146	4413		997	1830	1389	995	1779	1472
Peak-hour factor, PHF	1.00	1.00	1.00	1.00	1.00	1.00	1.00	1.00	1.00	1.00	1.00	1.00
Adj. Flow (vph)	589	1850	341	55	1124	95	206	177	81	52	211	518
RTOR Reduction (vph)	0	0	172	0	8	0	0	0	56	0	0	136
Lane Group Flow (vph)	589	1850	169	55	1211	0	206	177	25	52	211	382
Confl. Peds. (#/hr)							2					2
Confl. Bikes (#/hr)			1									
Heavy Vehicles (%)	10%	10%	2%	14%	18%	11%	5%	5%	15%	15%	8%	7%
Turn Type	pm+pt	NA	Perm	pm+pt	NA		Perm	NA	Perm	Perm	NA	Perm
Protected Phases	5	2		1	6			4			8	
Permitted Phases	2		2	6			4		4	8		8
Actuated Green, G (s)	68.8	59.3	59.3	51.6	45.1		37.4	37.4	37.4	37.4	37.4	37.4
Effective Green, g (s)	68.8	59.3	59.3	51.6	45.1		37.4	37.4	37.4	37.4	37.4	37.4
Actuated g/C Ratio	0.57	0.49	0.49	0.43	0.38		0.31	0.31	0.31	0.31	0.31	0.31
Clearance Time (s)	3.0	6.9	6.9	3.0	6.9		6.9	6.9	6.9	6.9	6.9	6.9
Vehicle Extension (s)	5.0	5.0	5.0	5.0	5.0		5.0	5.0	5.0	5.0	5.0	5.0
Lane Grp Cap (vph)	364	2356	757	139	1658		310	570	432	310	554	458
v/s Ratio Prot	c0.28	0.39		0.02	0.27			0.10			0.12	
v/s Ratio Perm	c0.65		0.11	0.15			0.21		0.02	0.05		c0.26
v/c Ratio	1.62	0.79	0.22	0.40	0.73		0.66	0.31	0.06	0.17	0.38	0.83
Uniform Delay, d1	32.1	25.1	17.2	21.5	32.2		35.9	31.5	29.0	30.0	32.3	38.4
Progression Factor	1.00	1.00	1.00	1.29	1.14		1.00	1.00	1.00	1.00	1.00	1.00
Incremental Delay, d2	290.6	2.7	0.7	3.5	2.6		6.9	0.7	0.1	0.5	0.9	13.7
Delay (s)	322.7	27.8	17.9	31.4	39.4		42.8	32.1	29.1	30.5	33.2	52.1
Level of Service	F	C	B	C	D		D	C	C	C	C	D
Approach Delay (s)		89.1			39.1			36.3			45.6	
Approach LOS		F			D			D			D	
<b>Intersection Summary</b>												
HCM 2000 Control Delay			66.0			HCM 2000 Level of Service			E			
HCM 2000 Volume to Capacity ratio			1.37									
Actuated Cycle Length (s)			120.0			Sum of lost time (s)			16.8			
Intersection Capacity Utilization			101.3%			ICU Level of Service			G			
Analysis Period (min)			15									

c Critical Lane Group

# HCM Signalized Intersection Capacity Analysis 2032 Future Background Conditions (Mitigation)

## 102: Dixie Rd & Mayfield Rd

























AM Peak Hour

Movement	EBL	EBT	EBR	WBL	WBT	WBR	NBL	NBT	NBR	SBL	SBT	SBR
Lane Configurations												
Traffic Volume (vph)	589	1850	341	55	1124	95	206	177	81	52	211	518
Future Volume (vph)	589	1850	341	55	1124	95	206	177	81	52	211	518
Ideal Flow (vphpl)	1900	1900	1900	1900	1900	1900	1900	1900	1900	1900	1900	1900
Lane Width	3.5	3.7	3.5	3.5	3.7	3.5	3.5	3.7	3.5	3.5	3.7	3.5
Total Lost time (s)	5.3	6.9	6.9	3.0	6.9		6.9	6.9	6.9	6.9	6.9	6.9
Lane Util. Factor	0.97	0.91	1.00	1.00	0.91		1.00	1.00	1.00	1.00	1.00	1.00
Frbp, ped/bikes	1.00	1.00	0.98	1.00	1.00		1.00	1.00	1.00	1.00	1.00	0.99
Flpb, ped/bikes	1.00	1.00	1.00	1.00	1.00		1.00	1.00	1.00	1.00	1.00	1.00
Frt	1.00	1.00	0.85	1.00	0.99		1.00	1.00	0.85	1.00	1.00	0.85
Flt Protected	0.95	1.00	1.00	0.95	1.00		0.95	1.00	1.00	0.95	1.00	1.00
Satd. Flow (prot)	3148	4768	1533	1566	4413		1698	1830	1389	1552	1779	1472
Flt Permitted	0.13	1.00	1.00	0.10	1.00		0.50	1.00	1.00	0.56	1.00	1.00
Satd. Flow (perm)	438	4768	1533	169	4413		887	1830	1389	909	1779	1472
Peak-hour factor, PHF	1.00	1.00	1.00	1.00	1.00	1.00	1.00	1.00	1.00	1.00	1.00	1.00
Adj. Flow (vph)	589	1850	341	55	1124	95	206	177	81	52	211	518
RTOR Reduction (vph)	0	0	140	0	5	0	0	0	60	0	0	382
Lane Group Flow (vph)	589	1850	201	55	1214	0	206	177	21	52	211	136
Confl. Peds. (#/hr)							2					2
Confl. Bikes (#/hr)			1									
Heavy Vehicles (%)	10%	10%	2%	14%	18%	11%	5%	5%	15%	15%	8%	7%
Turn Type	pm+pt	NA	Perm	pm+pt	NA		Perm	NA	Perm	Perm	NA	Perm
Protected Phases	5	2		1	6			4			8	
Permitted Phases	2		2	6			4		4	8		8
Actuated Green, G (s)	97.9	88.5	88.5	69.7	63.3		38.3	38.3	38.3	38.3	38.3	38.3
Effective Green, g (s)	97.9	88.5	88.5	69.7	63.3		38.3	38.3	38.3	38.3	38.3	38.3
Actuated g/C Ratio	0.65	0.59	0.59	0.46	0.42		0.26	0.26	0.26	0.26	0.26	0.26
Clearance Time (s)	5.3	6.9	6.9	3.0	6.9		6.9	6.9	6.9	6.9	6.9	6.9
Vehicle Extension (s)	5.0	5.0	5.0	5.0	5.0		5.0	5.0	5.0	5.0	5.0	5.0
Lane Grp Cap (vph)	815	2813	904	138	1862		226	467	354	232	454	375
v/s Ratio Prot	c0.14	0.39		0.02	0.28			0.10			0.12	
v/s Ratio Perm	c0.33		0.13	0.17			c0.23		0.01	0.06		0.09
v/c Ratio	0.72	0.66	0.22	0.40	0.65		0.91	0.38	0.06	0.22	0.46	0.36
Uniform Delay, d1	27.5	20.6	14.5	22.4	34.6		54.2	46.0	42.2	44.1	47.2	45.8
Progression Factor	1.00	1.00	1.00	1.00	1.00		1.00	1.00	1.00	1.00	1.00	1.00
Incremental Delay, d2	3.9	1.2	0.6	3.9	1.8		38.1	1.1	0.1	1.0	1.6	1.3
Delay (s)	31.4	21.8	15.1	26.3	36.4		92.3	47.1	42.4	45.1	48.8	47.1
Level of Service	C	C	B	C	D		F	D	D	D	D	D
Approach Delay (s)		23.0			35.9			66.4			47.4	
Approach LOS		C			D			E			D	
<b>Intersection Summary</b>												
HCM 2000 Control Delay			33.5			HCM 2000 Level of Service			C			
HCM 2000 Volume to Capacity ratio			0.79									
Actuated Cycle Length (s)			150.0			Sum of lost time (s)			19.1			
Intersection Capacity Utilization			86.5%			ICU Level of Service			E			
Analysis Period (min)			15									

c Critical Lane Group

HCM Signalized Intersection Capacity Analysis  
 104: Mayfield Rd & 12035 Dixie Rd Development Access

2032 Future Background Conditions  
 AM Peak Hour

												
Movement	EBL	EBT	EBR	WBL	WBT	WBR	NBL	NBT	NBR	SBL	SBT	SBR
Lane Configurations		  			 			 			 	
Traffic Volume (vph)	98	1884	0	0	1239	26	0	0	0	3	0	35
Future Volume (vph)	98	1884	0	0	1239	26	0	0	0	3	0	35
Ideal Flow (vphpl)	1900	1900	1900	1900	1900	1900	1900	1900	1900	1900	1900	1900
Lane Width	3.5	3.7	3.5	3.5	3.7	3.5	3.5	3.7	3.5	3.5	3.7	3.5
Total Lost time (s)	6.9	6.9			6.9						6.9	
Lane Util. Factor	1.00	0.91			0.95						1.00	
Fr <sub>t</sub>	1.00	1.00			1.00						0.88	
Fl <sub>t</sub> Protected	0.95	1.00			1.00						1.00	
Satd. Flow (prot)	1785	4768			3119						1676	
Fl <sub>t</sub> Permitted	0.21	1.00			1.00						0.97	
Satd. Flow (perm)	395	4768			3119						1634	
Peak-hour factor, PHF	1.00	1.00	1.00	1.00	1.00	1.00	1.00	1.00	1.00	1.00	1.00	1.00
Adj. Flow (vph)	98	1884	0	0	1239	26	0	0	0	3	0	35
RTOR Reduction (vph)	0	0	0	0	0	0	0	0	0	0	33	0
Lane Group Flow (vph)	98	1884	0	0	1265	0	0	0	0	0	5	0
Heavy Vehicles (%)	0%	10%	0%	0%	17%	0%	0%	0%	0%	0%	0%	0%
Turn Type	Perm	NA	Perm	Perm	NA					Perm	NA	
Protected Phases		2			6			8			4	
Permitted Phases	2		2	6			8			4		
Actuated Green, G (s)	100.7	100.7			100.7						5.5	
Effective Green, g (s)	100.7	100.7			100.7						5.5	
Actuated g/C Ratio	0.84	0.84			0.84						0.05	
Clearance Time (s)	6.9	6.9			6.9						6.9	
Vehicle Extension (s)	5.0	5.0			5.0						5.0	
Lane Grp Cap (vph)	331	4001			2617						74	
v/s Ratio Prot		0.40			c0.41							
v/s Ratio Perm	0.25										c0.00	
v/c Ratio	0.30	0.47			0.48						0.06	
Uniform Delay, d <sub>1</sub>	2.1	2.6			2.6						54.8	
Progression Factor	4.44	4.79			1.00						1.00	
Incremental Delay, d <sub>2</sub>	1.5	0.3			0.6						0.7	
Delay (s)	10.7	12.6			3.3						55.5	
Level of Service	B	B			A						E	
Approach Delay (s)		12.5			3.3			0.0			55.5	
Approach LOS		B			A			A			E	
<b>Intersection Summary</b>												
HCM 2000 Control Delay			9.4		HCM 2000 Level of Service					A		
HCM 2000 Volume to Capacity ratio			0.46									
Actuated Cycle Length (s)			120.0		Sum of lost time (s)				13.8			
Intersection Capacity Utilization			70.3%		ICU Level of Service					C		
Analysis Period (min)			15									

c Critical Lane Group

HCM Signalized Intersection Capacity Analysis  
101: Bramalea Rd & Mayfield Rd

2032 Future Background Conditions  
PM Peak Hour

Movement	EBL	EBT	EBR	WBL	WBT	WBR	NBL	NBT	NBR	SBL	SBT	SBR
Lane Configurations												
Traffic Volume (vph)	171	1146	174	144	1233	30	315	209	72	32	127	109
Future Volume (vph)	171	1146	174	144	1233	30	315	209	72	32	127	109
Ideal Flow (vphpl)	1900	1900	1900	1900	1900	1900	1900	1900	1900	1900	1900	1900
Lane Width	3.5	3.7	3.5	3.5	3.7	3.5	3.5	3.7	3.5	3.5	3.7	3.5
Total Lost time (s)	3.0	7.2	7.2	7.2	7.2	7.2	7.1	7.1	7.1	3.0	7.1	
Lane Util. Factor	1.00	0.91	1.00	1.00	0.91	1.00	1.00	1.00	1.00	1.00	0.95	
Frbp, ped/bikes	1.00	1.00	0.99	1.00	1.00	0.97	1.00	1.00	0.99	1.00	0.99	
Flpb, ped/bikes	1.00	1.00	1.00	1.00	1.00	1.00	1.00	1.00	1.00	1.00	1.00	
Frt	1.00	1.00	0.85	1.00	1.00	0.85	1.00	1.00	0.85	1.00	0.93	
Flt Protected	0.95	1.00	1.00	0.95	1.00	1.00	0.95	1.00	1.00	0.95	1.00	
Satd. Flow (prot)	1767	4683	1545	1784	4856	1480	1766	1921	1577	1785	3284	
Flt Permitted	0.14	1.00	1.00	0.23	1.00	1.00	0.60	1.00	1.00	0.53	1.00	
Satd. Flow (perm)	259	4683	1545	431	4856	1480	1125	1921	1577	988	3284	
Peak-hour factor, PHF	1.00	1.00	1.00	1.00	1.00	1.00	1.00	1.00	1.00	1.00	1.00	1.00
Adj. Flow (vph)	171	1146	174	144	1233	30	315	209	72	32	127	109
RTOR Reduction (vph)	0	0	86	0	0	17	0	0	49	0	68	0
Lane Group Flow (vph)	171	1146	88	144	1233	13	315	209	23	32	168	0
Confl. Peds. (#/hr)	6		2	2		6	1					1
Confl. Bikes (#/hr)									1			
Heavy Vehicles (%)	1%	12%	2%	0%	8%	5%	1%	0%	0%	0%	1%	5%
Turn Type	pm+pt	NA	Perm	Perm	NA	Perm	Perm	NA	Perm	pm+pt	NA	
Protected Phases	5	2			6			4		3	8	
Permitted Phases	2		2	6		6	4		4	8		
Actuated Green, G (s)	63.0	63.0	63.0	52.9	52.9	52.9	40.1	40.1	40.1	46.9	46.9	
Effective Green, g (s)	63.0	63.0	63.0	52.9	52.9	52.9	40.1	40.1	40.1	46.9	46.9	
Actuated g/C Ratio	0.51	0.51	0.51	0.43	0.43	0.43	0.32	0.32	0.32	0.38	0.38	
Clearance Time (s)	3.0	7.2	7.2	7.2	7.2	7.2	7.1	7.1	7.1	3.0	7.1	
Vehicle Extension (s)	5.0	5.0	5.0	5.0	5.0	5.0	5.0	5.0	5.0	5.0	5.0	
Lane Grp Cap (vph)	217	2375	783	183	2068	630	363	620	509	397	1240	
v/s Ratio Prot	c0.04	0.24			0.25			0.11		0.00	c0.05	
v/s Ratio Perm	c0.35		0.06	0.33		0.01	c0.28		0.01	0.03		
v/c Ratio	0.79	0.48	0.11	0.79	0.60	0.02	0.87	0.34	0.05	0.08	0.14	
Uniform Delay, d1	19.4	20.0	16.0	30.8	27.4	20.6	39.6	32.0	28.9	24.7	25.4	
Progression Factor	1.00	1.00	1.00	1.00	1.00	1.00	1.00	1.00	1.00	1.00	1.00	
Incremental Delay, d2	19.5	0.7	0.3	28.1	1.3	0.1	20.6	0.7	0.1	0.2	0.1	
Delay (s)	38.9	20.7	16.3	58.9	28.7	20.7	60.2	32.6	29.0	24.9	25.5	
Level of Service	D	C	B	E	C	C	E	C	C	C	C	
Approach Delay (s)		22.2			31.6			46.7			25.4	
Approach LOS		C			C			D			C	
<b>Intersection Summary</b>												
HCM 2000 Control Delay			29.9		HCM 2000 Level of Service					C		
HCM 2000 Volume to Capacity ratio			0.81									
Actuated Cycle Length (s)			124.2		Sum of lost time (s)				20.3			
Intersection Capacity Utilization			102.8%		ICU Level of Service				G			
Analysis Period (min)			15									

c Critical Lane Group

HCM Signalized Intersection Capacity Analysis  
102: Dixie Rd & Mayfield Rd

2032 Future Background Conditions  
PM Peak Hour

























Movement	EBL	EBT	EBR	WBL	WBT	WBR	NBL	NBT	NBR	SBL	SBT	SBR
Lane Configurations												
Traffic Volume (vph)	575	1646	295	97	1831	77	275	276	76	86	219	699
Future Volume (vph)	575	1646	295	97	1831	77	275	276	76	86	219	699
Ideal Flow (vphpl)	1900	1900	1900	1900	1900	1900	1900	1900	1900	1900	1900	1900
Lane Width	3.5	3.7	3.5	3.5	3.7	3.5	3.5	3.7	3.5	3.5	3.7	3.5
Total Lost time (s)	3.0	6.9	6.9	3.0	6.9		6.9	6.9	6.9	6.9	6.9	6.9
Lane Util. Factor	1.00	0.91	1.00	1.00	0.91		1.00	1.00	1.00	1.00	1.00	1.00
Frbp, ped/bikes	1.00	1.00	1.00	1.00	1.00		1.00	1.00	0.99	1.00	1.00	0.98
Flpb, ped/bikes	1.00	1.00	1.00	1.00	1.00		1.00	1.00	1.00	1.00	1.00	1.00
Frt	1.00	1.00	0.85	1.00	0.99		1.00	1.00	0.85	1.00	1.00	0.85
Flt Protected	0.95	1.00	1.00	0.95	1.00		0.95	1.00	1.00	0.95	1.00	1.00
Satd. Flow (prot)	1580	4683	1581	1684	4846		1763	1865	1432	1698	1883	1440
Flt Permitted	0.09	1.00	1.00	0.10	1.00		0.57	1.00	1.00	0.50	1.00	1.00
Satd. Flow (perm)	154	4683	1581	177	4846		1065	1865	1432	899	1883	1440
Peak-hour factor, PHF	1.00	1.00	1.00	1.00	1.00	1.00	1.00	1.00	1.00	1.00	1.00	1.00
Adj. Flow (vph)	575	1646	295	97	1831	77	275	276	76	86	219	699
RTOR Reduction (vph)	0	0	170	0	4	0	0	0	47	0	0	176
Lane Group Flow (vph)	575	1646	125	97	1904	0	275	276	29	86	219	523
Confl. Peds. (#/hr)	5					5	4		2	2		4
Confl. Bikes (#/hr)												3
Heavy Vehicles (%)	13%	12%	1%	6%	7%	18%	1%	3%	10%	5%	2%	9%
Turn Type	pm+pt	NA	Perm	pm+pt	NA		Perm	NA	Perm	Perm	NA	Perm
Protected Phases	5	2		1	6			4			8	
Permitted Phases	2		2	6			4		4	8		8
Actuated Green, G (s)	61.0	50.7	50.7	47.4	40.1		45.2	45.2	45.2	45.2	45.2	45.2
Effective Green, g (s)	61.0	50.7	50.7	47.4	40.1		45.2	45.2	45.2	45.2	45.2	45.2
Actuated g/C Ratio	0.51	0.42	0.42	0.39	0.33		0.38	0.38	0.38	0.38	0.38	0.38
Clearance Time (s)	3.0	6.9	6.9	3.0	6.9		6.9	6.9	6.9	6.9	6.9	6.9
Vehicle Extension (s)	5.0	5.0	5.0	5.0	5.0		5.0	5.0	5.0	5.0	5.0	5.0
Lane Grp Cap (vph)	290	1978	667	161	1619		401	702	539	338	709	542
v/s Ratio Prot	c0.29	0.35		0.04	0.39			0.15			0.12	
v/s Ratio Perm	c0.71		0.08	0.20			0.26		0.02	0.10		c0.36
v/c Ratio	1.98	0.83	0.19	0.60	1.18		0.69	0.39	0.05	0.25	0.31	0.96
Uniform Delay, d1	37.6	30.9	21.7	25.1	40.0		31.4	27.4	23.8	25.8	26.4	36.6
Progression Factor	1.00	1.00	1.00	0.93	0.84		1.00	1.00	1.00	1.00	1.00	1.00
Incremental Delay, d2	454.4	4.3	0.6	6.4	84.1		6.2	0.8	0.1	0.8	0.5	30.0
Delay (s)	492.1	35.1	22.3	29.8	117.8		37.6	28.1	23.9	26.6	26.9	66.6
Level of Service	F	D	C	C	F		D	C	C	C	C	E
Approach Delay (s)		138.1			113.5			31.8			54.5	
Approach LOS		F			F			C			D	
<b>Intersection Summary</b>												
HCM 2000 Control Delay			105.6	HCM 2000 Level of Service				F				
HCM 2000 Volume to Capacity ratio			1.58									
Actuated Cycle Length (s)			120.0	Sum of lost time (s)				16.8				
Intersection Capacity Utilization			119.6%	ICU Level of Service				H				
Analysis Period (min)			15									

c Critical Lane Group

# HCM Signalized Intersection Capacity Analysis 2032 Future Background Conditions (Mitigation)

102: Dixie Rd & Mayfield Rd

























PM Peak Hour

												
Movement	EBL	EBT	EBR	WBL	WBT	WBR	NBL	NBT	NBR	SBL	SBT	SBR
Lane Configurations												
Traffic Volume (vph)	575	1646	295	97	1831	77	275	276	76	86	219	699
Future Volume (vph)	575	1646	295	97	1831	77	275	276	76	86	219	699
Ideal Flow (vphpl)	1900	1900	1900	1900	1900	1900	1900	1900	1900	1900	1900	1900
Lane Width	3.5	3.7	3.5	3.5	3.7	3.5	3.5	3.7	3.5	3.5	3.7	3.5
Total Lost time (s)	3.0	6.9	6.9	3.0	6.9		6.9	6.9	6.9	6.9	6.9	3.0
Lane Util. Factor	0.97	0.91	1.00	1.00	0.91		1.00	1.00	1.00	1.00	1.00	1.00
Frbp, ped/bikes	1.00	1.00	1.00	1.00	1.00		1.00	1.00	0.99	1.00	1.00	0.99
Flpb, ped/bikes	1.00	1.00	1.00	1.00	1.00		1.00	1.00	1.00	1.00	1.00	1.00
Frt	1.00	1.00	0.85	1.00	0.99		1.00	1.00	0.85	1.00	1.00	0.85
Flt Protected	0.95	1.00	1.00	0.95	1.00		0.95	1.00	1.00	0.95	1.00	1.00
Satd. Flow (prot)	3064	4683	1581	1684	4848		1762	1865	1432	1698	1883	1449
Flt Permitted	0.06	1.00	1.00	0.11	1.00		0.52	1.00	1.00	0.43	1.00	1.00
Satd. Flow (perm)	200	4683	1581	194	4848		961	1865	1432	776	1883	1449
Peak-hour factor, PHF	1.00	1.00	1.00	1.00	1.00	1.00	1.00	1.00	1.00	1.00	1.00	1.00
Adj. Flow (vph)	575	1646	295	97	1831	77	275	276	76	86	219	699
RTOR Reduction (vph)	0	0	142	0	3	0	0	0	53	0	0	15
Lane Group Flow (vph)	575	1646	153	97	1905	0	275	276	23	86	219	684
Confl. Peds. (#/hr)	5					5	4		2	2		4
Confl. Bikes (#/hr)												3
Heavy Vehicles (%)	13%	12%	1%	6%	7%	18%	1%	3%	10%	5%	2%	9%
Turn Type	pm+pt	NA	Perm	pm+pt	NA		Perm	NA	Perm	Perm	NA	pm+ov
Protected Phases	5	2		1	6			4		4	8	5
Permitted Phases	2		2	6			4		4	8		8
Actuated Green, G (s)	90.7	78.0	78.0	71.3	61.6		45.5	45.5	45.5	45.5	45.5	71.6
Effective Green, g (s)	90.7	78.0	78.0	71.3	61.6		45.5	45.5	45.5	45.5	45.5	71.6
Actuated g/C Ratio	0.60	0.52	0.52	0.48	0.41		0.30	0.30	0.30	0.30	0.30	0.48
Clearance Time (s)	3.0	6.9	6.9	3.0	6.9		6.9	6.9	6.9	6.9	6.9	3.0
Vehicle Extension (s)	5.0	5.0	5.0	5.0	5.0		5.0	5.0	5.0	5.0	5.0	5.0
Lane Grp Cap (vph)	619	2435	822	188	1990		291	565	434	235	571	691
v/s Ratio Prot	0.16	0.35		0.03	0.39			0.15			0.12	c0.17
v/s Ratio Perm	c0.40		0.10	0.21			0.29		0.02	0.11		0.30
v/c Ratio	0.93	0.68	0.19	0.52	0.96		0.95	0.49	0.05	0.37	0.38	0.99
Uniform Delay, d1	49.3	26.6	19.1	22.8	42.9		51.0	42.7	37.0	40.9	41.2	38.9
Progression Factor	1.00	1.00	1.00	1.00	1.00		1.00	1.00	1.00	1.00	1.00	1.00
Incremental Delay, d2	21.1	1.5	0.5	4.7	12.3		38.9	1.4	0.1	2.0	0.9	31.8
Delay (s)	70.4	28.2	19.6	27.5	55.3		89.9	44.1	37.1	43.0	42.1	70.7
Level of Service	E	C	B	C	E		F	D	D	D	D	E
Approach Delay (s)		36.8			53.9			63.3			62.1	
Approach LOS		D			D			E			E	
<b>Intersection Summary</b>												
HCM 2000 Control Delay			49.2	HCM 2000 Level of Service						D		
HCM 2000 Volume to Capacity ratio			0.98									
Actuated Cycle Length (s)			150.0	Sum of lost time (s)				16.8				
Intersection Capacity Utilization			110.9%	ICU Level of Service				H				
Analysis Period (min)			15									

c Critical Lane Group

HCM Signalized Intersection Capacity Analysis  
 104: Mayfield Rd & 12035 Dixie Rd Development Access

2032 Future Background Conditions  
 PM Peak Hour

												
Movement	EBL	EBT	EBR	WBL	WBT	WBR	NBL	NBT	NBR	SBL	SBT	SBR
Lane Configurations		  			 			 			 	
Traffic Volume (vph)	43	1765	0	0	1900	3	0	0	0	27	0	104
Future Volume (vph)	43	1765	0	0	1900	3	0	0	0	27	0	104
Ideal Flow (vphpl)	1900	1900	1900	1900	1900	1900	1900	1900	1900	1900	1900	1900
Lane Width	3.5	3.7	3.5	3.5	3.7	3.5	3.5	3.7	3.5	3.5	3.7	3.5
Total Lost time (s)	6.9	6.9			6.9							6.9
Lane Util. Factor	1.00	0.91			0.95							1.00
Frt	1.00	1.00			1.00							0.89
Flt Protected	0.95	1.00			1.00							0.99
Satd. Flow (prot)	1785	4683			3411							1698
Flt Permitted	0.08	1.00			1.00							0.93
Satd. Flow (perm)	148	4683			3411							1592
Peak-hour factor, PHF	1.00	1.00	1.00	1.00	1.00	1.00	1.00	1.00	1.00	1.00	1.00	1.00
Adj. Flow (vph)	43	1765	0	0	1900	3	0	0	0	27	0	104
RTOR Reduction (vph)	0	0	0	0	0	0	0	0	0	0	31	0
Lane Group Flow (vph)	43	1765	0	0	1903	0	0	0	0	0	100	0
Heavy Vehicles (%)	0%	12%	0%	0%	7%	0%	0%	0%	0%	0%	0%	0%
Turn Type	Perm	NA	Perm	Perm	NA						Perm	NA
Protected Phases		2			6			8				4
Permitted Phases	2		2	6			8			4		
Actuated Green, G (s)	91.7	91.7			91.7							14.5
Effective Green, g (s)	91.7	91.7			91.7							14.5
Actuated g/C Ratio	0.76	0.76			0.76							0.12
Clearance Time (s)	6.9	6.9			6.9							6.9
Vehicle Extension (s)	5.0	5.0			5.0							5.0
Lane Grp Cap (vph)	113	3578			2606							192
v/s Ratio Prot		0.38			c0.56							
v/s Ratio Perm	0.29											c0.06
v/c Ratio	0.38	0.49			0.73							0.52
Uniform Delay, d1	4.7	5.4			7.6							49.5
Progression Factor	2.45	2.03			1.00							1.00
Incremental Delay, d2	5.8	0.3			1.8							4.8
Delay (s)	17.3	11.2			9.4							54.3
Level of Service	B	B			A							D
Approach Delay (s)		11.3			9.4			0.0				54.3
Approach LOS		B			A			A				D
<b>Intersection Summary</b>												
HCM 2000 Control Delay			11.8		HCM 2000 Level of Service					B		
HCM 2000 Volume to Capacity ratio			0.70									
Actuated Cycle Length (s)			120.0		Sum of lost time (s)				13.8			
Intersection Capacity Utilization			72.0%		ICU Level of Service					C		
Analysis Period (min)			15									

c Critical Lane Group

Queues  
101: Bramalea Rd & Mayfield Rd

2032 Future Background Conditions  
AM Peak Hour



Lane Group	EBL	EBT	EBR	WBL	WBT	WBR	NBL	NBT	NBR	SBL	SBT
Lane Group Flow (vph)	343	1269	264	133	895	30	80	175	72	58	446
v/c Ratio	0.82	0.44	0.26	0.74	0.39	0.05	0.54	0.56	0.23	0.20	0.47
Control Delay	29.9	12.0	2.0	49.9	16.7	0.1	53.0	46.4	8.8	27.4	20.7
Queue Delay	0.0	0.0	0.0	0.0	0.0	0.0	0.0	0.0	0.0	0.0	0.0
Total Delay	29.9	12.0	2.0	49.9	16.7	0.1	53.0	46.4	8.8	27.4	20.7
Queue Length 50th (m)	25.4	43.4	0.0	18.8	35.9	0.0	13.7	30.2	0.0	7.8	21.7
Queue Length 95th (m)	#68.9	64.3	10.0	#56.5	52.7	0.0	27.8	49.2	8.9	16.1	34.4
Internal Link Dist (m)		182.8			347.4			479.0			343.8
Turn Bay Length (m)	180.0		110.0	80.0		100.0	100.0			110.0	
Base Capacity (vph)	418	2872	1031	180	2286	634	446	932	758	285	2095
Starvation Cap Reductn	0	0	0	0	0	0	0	0	0	0	0
Spillback Cap Reductn	0	0	0	0	0	0	0	0	0	0	0
Storage Cap Reductn	0	0	0	0	0	0	0	0	0	0	0
Reduced v/c Ratio	0.82	0.44	0.26	0.74	0.39	0.05	0.18	0.19	0.09	0.20	0.21

Intersection Summary

# 95th percentile volume exceeds capacity, queue may be longer.  
Queue shown is maximum after two cycles.

Queues  
102: Dixie Rd & Mayfield Rd

2032 Future Background Conditions  
AM Peak Hour



Lane Group	EBL	EBT	EBR	WBL	WBT	NBL	NBT	NBR	SBL	SBT	SBR
Lane Group Flow (vph)	589	1850	341	55	1219	206	177	81	52	211	518
v/c Ratio	1.59	0.78	0.36	0.34	0.73	0.66	0.31	0.16	0.17	0.38	0.87
Control Delay	302.5	29.9	3.5	22.2	39.4	45.1	31.2	4.9	28.0	32.6	39.0
Queue Delay	0.0	0.0	0.0	0.0	0.0	0.0	0.0	0.0	0.0	0.0	0.0
Total Delay	302.5	29.9	3.5	22.2	39.4	45.1	31.2	4.9	28.0	32.6	39.0
Queue Length 50th (m)	~168.8	128.1	0.0	6.5	95.7	37.6	28.4	0.0	8.0	34.7	68.2
Queue Length 95th (m)	#252.9	#162.0	15.4	14.9	112.4	57.2	41.3	7.7	15.5	49.2	103.4
Internal Link Dist (m)		507.8			328.1		418.0			489.9	
Turn Bay Length (m)	170.0		100.0	150.0		120.0		50.0	80.0		170.0
Base Capacity (vph)	371	2379	935	164	1666	383	703	589	382	683	686
Starvation Cap Reductn	0	0	0	0	0	0	0	0	0	0	0
Spillback Cap Reductn	0	0	0	0	0	0	0	0	0	0	0
Storage Cap Reductn	0	0	0	0	0	0	0	0	0	0	0
Reduced v/c Ratio	1.59	0.78	0.36	0.34	0.73	0.54	0.25	0.14	0.14	0.31	0.76

Intersection Summary

~ Volume exceeds capacity, queue is theoretically infinite.

Queue shown is maximum after two cycles.

# 95th percentile volume exceeds capacity, queue may be longer.

Queue shown is maximum after two cycles.

Queues  
102: Dixie Rd & Mayfield Rd

2032 Future Background Conditions (Mitigation)  
AM Peak Hour



Lane Group	EBL	EBT	EBR	WBL	WBT	NBL	NBT	NBR	SBL	SBT	SBR
Lane Group Flow (vph)	589	1850	341	55	1219	206	177	81	52	211	518
v/c Ratio	0.72	0.65	0.33	0.35	0.65	0.91	0.38	0.19	0.22	0.46	0.68
Control Delay	27.5	23.2	2.5	22.6	38.9	94.0	47.1	7.0	44.1	49.4	8.5
Queue Delay	0.0	0.0	0.0	0.0	0.0	0.0	0.0	0.0	0.0	0.0	0.0
Total Delay	27.5	23.2	2.5	22.6	38.9	94.0	47.1	7.0	44.1	49.4	8.5
Queue Length 50th (m)	46.7	131.1	0.0	5.0	99.4	53.9	39.3	0.0	11.1	48.0	1.0
Queue Length 95th (m)	65.8	151.4	13.1	11.4	132.9	#89.1	57.2	10.0	21.4	68.0	29.4
Internal Link Dist (m)		507.8			328.1		418.0			489.9	
Turn Bay Length (m)	170.0		100.0	150.0		120.0		50.0	80.0		170.0
Base Capacity (vph)	1043	2832	1049	158	1864	266	550	479	273	534	801
Starvation Cap Reductn	0	0	0	0	0	0	0	0	0	0	0
Spillback Cap Reductn	0	0	0	0	0	0	0	0	0	0	0
Storage Cap Reductn	0	0	0	0	0	0	0	0	0	0	0
Reduced v/c Ratio	0.56	0.65	0.33	0.35	0.65	0.77	0.32	0.17	0.19	0.40	0.65

Intersection Summary

# 95th percentile volume exceeds capacity, queue may be longer.  
Queue shown is maximum after two cycles.

## Queues

2032 Future Background Conditions

104: Mayfield Rd &amp; 12035 Dixie Rd Development Access

AM Peak Hour



Lane Group	EBL	EBT	WBT	SBT
Lane Group Flow (vph)	98	1884	1265	38
v/c Ratio	0.28	0.45	0.46	0.25
Control Delay	13.9	12.3	3.2	22.5
Queue Delay	0.0	0.0	0.0	0.0
Total Delay	13.9	12.3	3.2	22.5
Queue Length 50th (m)	15.3	118.5	34.4	0.6
Queue Length 95th (m)	m24.9	150.4	49.8	10.4
Internal Link Dist (m)		328.1	608.7	157.9
Turn Bay Length (m)	50.0			
Base Capacity (vph)	349	4219	2761	635
Starvation Cap Reductn	0	0	0	0
Spillback Cap Reductn	0	0	0	0
Storage Cap Reductn	0	0	0	0
Reduced v/c Ratio	0.28	0.45	0.46	0.06

## Intersection Summary

m Volume for 95th percentile queue is metered by upstream signal.

Queues  
101: Bramalea Rd & Mayfield Rd

2032 Future Background Conditions  
PM Peak Hour



Lane Group	EBL	EBT	EBR	WBL	WBT	WBR	NBL	NBT	NBR	SBL	SBT
Lane Group Flow (vph)	171	1146	174	144	1233	30	315	209	72	32	236
v/c Ratio	0.75	0.48	0.20	0.78	0.59	0.04	0.86	0.33	0.13	0.07	0.18
Control Delay	41.8	22.5	3.6	64.3	30.5	0.1	61.8	32.7	5.3	20.5	12.7
Queue Delay	0.0	0.0	0.0	0.0	0.0	0.0	0.0	0.0	0.0	0.0	0.0
Total Delay	41.8	22.5	3.6	64.3	30.5	0.1	61.8	32.7	5.3	20.5	12.7
Queue Length 50th (m)	21.3	66.8	0.0	30.2	84.6	0.0	68.3	36.7	0.0	4.2	9.5
Queue Length 95th (m)	#52.1	87.6	11.8	#72.2	108.5	0.0	#103.9	55.1	7.7	9.7	16.9
Internal Link Dist (m)		182.8			347.4			479.0			343.8
Turn Bay Length (m)	180.0		110.0	80.0		100.0	100.0			110.0	
Base Capacity (vph)	228	2395	875	185	2083	680	473	808	710	445	1707
Starvation Cap Reductn	0	0	0	0	0	0	0	0	0	0	0
Spillback Cap Reductn	0	0	0	0	0	0	0	0	0	0	0
Storage Cap Reductn	0	0	0	0	0	0	0	0	0	0	0
Reduced v/c Ratio	0.75	0.48	0.20	0.78	0.59	0.04	0.67	0.26	0.10	0.07	0.14

Intersection Summary

# 95th percentile volume exceeds capacity, queue may be longer.  
Queue shown is maximum after two cycles.

Queues  
102: Dixie Rd & Mayfield Rd

2032 Future Background Conditions  
PM Peak Hour



Lane Group	EBL	EBT	EBR	WBL	WBT	NBL	NBT	NBR	SBL	SBT	SBR
Lane Group Flow (vph)	575	1646	295	97	1908	275	276	76	86	219	699
v/c Ratio	1.94	0.83	0.35	0.58	1.18	0.69	0.39	0.13	0.25	0.31	0.97
Control Delay	459.5	35.6	3.7	27.2	115.8	41.5	29.2	4.0	27.9	27.6	50.0
Queue Delay	0.0	0.0	0.0	0.0	0.0	0.0	0.0	0.0	0.0	0.0	0.0
Total Delay	459.5	35.6	3.7	27.2	115.8	41.5	29.2	4.0	27.9	27.6	50.0
Queue Length 50th (m)	~183.4	115.5	0.0	8.7	~182.1	49.0	42.8	0.0	12.6	32.7	100.4
Queue Length 95th (m)	#246.2	134.3	14.7	m12.8	#209.4	78.7	63.6	6.9	24.4	50.3	#176.5
Internal Link Dist (m)		507.8			328.1		418.0			489.9	
Turn Bay Length (m)	170.0		100.0	150.0		120.0		50.0	80.0		170.0
Base Capacity (vph)	296	1980	838	167	1623	409	716	605	345	723	727
Starvation Cap Reductn	0	0	0	0	0	0	0	0	0	0	0
Spillback Cap Reductn	0	0	0	0	0	0	0	0	0	0	0
Storage Cap Reductn	0	0	0	0	0	0	0	0	0	0	0
Reduced v/c Ratio	1.94	0.83	0.35	0.58	1.18	0.67	0.39	0.13	0.25	0.30	0.96

Intersection Summary

~ Volume exceeds capacity, queue is theoretically infinite.

Queue shown is maximum after two cycles.

# 95th percentile volume exceeds capacity, queue may be longer.

Queue shown is maximum after two cycles.

m Volume for 95th percentile queue is metered by upstream signal.

Queues  
102: Dixie Rd & Mayfield Rd

2032 Future Background Conditions (Mitigation)  
PM Peak Hour



Lane Group	EBL	EBT	EBR	WBL	WBT	NBL	NBT	NBR	SBL	SBT	SBR
Lane Group Flow (vph)	575	1646	295	97	1908	275	276	76	86	219	699
v/c Ratio	0.92	0.68	0.31	0.50	0.96	0.95	0.49	0.16	0.37	0.38	0.94
Control Delay	65.9	28.9	2.9	24.2	54.9	90.9	45.5	7.9	45.2	42.8	53.8
Queue Delay	0.0	0.0	0.0	0.0	0.0	0.0	0.0	0.0	0.0	0.0	0.0
Total Delay	65.9	28.9	2.9	24.2	54.9	90.9	45.5	7.9	45.2	42.8	53.8
Queue Length 50th (m)	68.3	124.5	0.0	10.4	185.3	71.9	60.4	0.0	18.1	46.2	161.6
Queue Length 95th (m)	#104.0	140.4	13.6	18.2	#217.2	#121.5	85.8	10.7	33.3	67.7	#250.8
Internal Link Dist (m)		507.8			328.1		418.0			489.9	
Turn Bay Length (m)	170.0		100.0	150.0		120.0		50.0	80.0		170.0
Base Capacity (vph)	623	2436	963	197	1996	308	598	510	248	603	742
Starvation Cap Reductn	0	0	0	0	0	0	0	0	0	0	0
Spillback Cap Reductn	0	0	0	0	0	0	0	0	0	0	0
Storage Cap Reductn	0	0	0	0	0	0	0	0	0	0	0
Reduced v/c Ratio	0.92	0.68	0.31	0.49	0.96	0.89	0.46	0.15	0.35	0.36	0.94

Intersection Summary

# 95th percentile volume exceeds capacity, queue may be longer.  
Queue shown is maximum after two cycles.

## Queues

2032 Future Background Conditions

104: Mayfield Rd &amp; 12035 Dixie Rd Development Access

PM Peak Hour



Lane Group	EBL	EBT	WBT	SBT
Lane Group Flow (vph)	43	1765	1903	131
v/c Ratio	0.38	0.49	0.73	0.59
Control Delay	26.0	12.1	10.4	46.2
Queue Delay	0.0	0.0	0.0	0.0
Total Delay	26.0	12.1	10.4	46.2
Queue Length 50th (m)	4.4	68.7	98.2	19.8
Queue Length 95th (m)	m7.0	89.7	151.8	36.4
Internal Link Dist (m)		328.1	608.7	157.9
Turn Bay Length (m)	50.0			
Base Capacity (vph)	113	3577	2606	620
Starvation Cap Reductn	0	0	0	0
Spillback Cap Reductn	0	0	0	0
Storage Cap Reductn	0	0	0	0
Reduced v/c Ratio	0.38	0.49	0.73	0.21

## Intersection Summary





























m Volume for 95th percentile queue is metered by upstream signal.

## **Appendix E**

### **Future (2027) Total Intersection Operation Calculations (Synchro)**



























HCM Signalized Intersection Capacity Analysis  
101: Bramalea Rd & Mayfield Rd

2027 Future Total Conditions  
AM Peak Hour

													
Movement	EBL	EBT	EBR	WBL	WBT	WBR	NBL	NBT	NBR	SBL	SBT	SBR	
Lane Configurations		  			  						 		
Traffic Volume (vph)	291	1073	224	112	763	25	68	147	61	49	211	164	
Future Volume (vph)	291	1073	224	112	763	25	68	147	61	49	211	164	
Ideal Flow (vphpl)	1900	1900	1900	1900	1900	1900	1900	1900	1900	1900	1900	1900	
Lane Width	3.5	3.7	3.5	3.5	3.7	3.5	3.5	3.7	3.5	3.5	3.7	3.5	
Total Lost time (s)	3.0	7.2	7.2	7.2	7.2	7.2	7.1	7.1	7.1	3.0	7.1		
Lane Util. Factor	1.00	0.91	1.00	1.00	0.91	1.00	1.00	1.00	1.00	1.00	0.95		
Frpb, ped/bikes	1.00	1.00	0.99	1.00	1.00	1.00	1.00	1.00	0.98	1.00	1.00		
Flpb, ped/bikes	1.00	1.00	1.00	1.00	1.00	1.00	1.00	1.00	1.00	1.00	1.00		
Frt	1.00	1.00	0.85	1.00	1.00	0.85	1.00	1.00	0.85	1.00	0.93		
Flt Protected	0.95	1.00	1.00	0.95	1.00	1.00	0.95	1.00	1.00	0.95	1.00		
Satd. Flow (prot)	1785	4683	1515	1608	4445	1157	1700	1847	1427	1590	3362		
Flt Permitted	0.32	1.00	1.00	0.25	1.00	1.00	0.53	1.00	1.00	0.54	1.00		
Satd. Flow (perm)	604	4683	1515	430	4445	1157	947	1847	1427	901	3362		
Peak-hour factor, PHF	1.00	1.00	1.00	1.00	1.00	1.00	1.00	1.00	1.00	1.00	1.00	1.00	
Adj. Flow (vph)	291	1073	224	112	763	25	68	147	61	49	211	164	
RTOR Reduction (vph)	0	0	85	0	0	12	0	0	52	0	125	0	
Lane Group Flow (vph)	291	1073	139	112	763	13	68	147	9	49	250	0	
Confl. Peds. (#/hr)			2	2					9	9			
Heavy Vehicles (%)	0%	12%	4%	11%	18%	38%	5%	4%	10%	12%	1%	2%	
Turn Type	pm+pt	NA	Perm	Perm	NA	Perm	Perm	NA	Perm	pm+pt	NA		
Protected Phases	5	2			6			4		3	8		
Permitted Phases	2		2	6		6	4		4	8			
Actuated Green, G (s)	62.3	62.3	62.3	52.3	52.3	52.3	15.3	15.3	15.3	23.7	23.7		
Effective Green, g (s)	62.3	62.3	62.3	52.3	52.3	52.3	15.3	15.3	15.3	23.7	23.7		
Actuated g/C Ratio	0.62	0.62	0.62	0.52	0.52	0.52	0.15	0.15	0.15	0.24	0.24		
Clearance Time (s)	3.0	7.2	7.2	7.2	7.2	7.2	7.1	7.1	7.1	3.0	7.1		
Vehicle Extension (s)	5.0	5.0	5.0	5.0	5.0	5.0	5.0	5.0	5.0	5.0	5.0		
Lane Grp Cap (vph)	457	2908	941	224	2317	603	144	281	217	249	794		
v/s Ratio Prot	c0.04	0.23			0.17			c0.08		0.01	c0.07		
v/s Ratio Perm	c0.35		0.09	0.26		0.01	0.07		0.01	0.04			
v/c Ratio	0.64	0.37	0.15	0.50	0.33	0.02	0.47	0.52	0.04	0.20	0.31		
Uniform Delay, d1	9.0	9.3	7.9	15.5	13.9	11.6	38.8	39.1	36.3	30.2	31.6		
Progression Factor	1.00	1.00	1.00	1.00	1.00	1.00	1.00	1.00	1.00	1.00	1.00		
Incremental Delay, d2	4.0	0.4	0.3	7.8	0.4	0.1	5.0	3.3	0.2	0.8	0.5		
Delay (s)	13.0	9.7	8.3	23.3	14.2	11.7	43.9	42.5	36.4	31.1	32.1		
Level of Service	B	A	A	C	B	B	D	D	D	C	C		
Approach Delay (s)		10.1			15.3			41.5			32.0		
Approach LOS		B			B			D			C		
<b>Intersection Summary</b>													
HCM 2000 Control Delay			17.2		HCM 2000 Level of Service						B		
HCM 2000 Volume to Capacity ratio			0.62										
Actuated Cycle Length (s)			100.3		Sum of lost time (s)						20.3		
Intersection Capacity Utilization			95.5%		ICU Level of Service						F		
Analysis Period (min)			15										
c	Critical Lane Group												

HCM Signalized Intersection Capacity Analysis  
102: Dixie Rd & Mayfield Rd



























2027 Future Total Conditions  
AM Peak Hour

												
Movement	EBL	EBT	EBR	WBL	WBT	WBR	NBL	NBT	NBR	SBL	SBT	SBR
Lane Configurations		  			  							
Traffic Volume (vph)	528	1569	287	49	955	87	173	159	72	44	180	452
Future Volume (vph)	528	1569	287	49	955	87	173	159	72	44	180	452
Ideal Flow (vphpl)	1900	1900	1900	1900	1900	1900	1900	1900	1900	1900	1900	1900
Lane Width	3.5	3.7	3.5	3.5	3.7	3.5	3.5	3.7	3.5	3.5	3.7	3.5
Total Lost time (s)	3.0	6.9	6.9	3.0	6.9		6.9	6.9	6.9	6.9	6.9	6.9
Lane Util. Factor	1.00	0.91	1.00	1.00	0.91		1.00	1.00	1.00	1.00	1.00	1.00
Frbp, ped/bikes	1.00	1.00	0.98	1.00	1.00		1.00	1.00	1.00	1.00	1.00	0.99
Flpb, ped/bikes	1.00	1.00	1.00	1.00	1.00		1.00	1.00	1.00	1.00	1.00	1.00
Frt	1.00	1.00	0.85	1.00	0.99		1.00	1.00	0.85	1.00	1.00	0.85
Flt Protected	0.95	1.00	1.00	0.95	1.00		0.95	1.00	1.00	0.95	1.00	1.00
Satd. Flow (prot)	1623	4768	1533	1566	4411		1698	1830	1389	1552	1779	1472
Flt Permitted	0.17	1.00	1.00	0.15	1.00		0.58	1.00	1.00	0.62	1.00	1.00
Satd. Flow (perm)	297	4768	1533	248	4411		1043	1830	1389	1015	1779	1472
Peak-hour factor, PHF	1.00	1.00	1.00	1.00	1.00	1.00	1.00	1.00	1.00	1.00	1.00	1.00
Adj. Flow (vph)	528	1569	287	49	955	87	173	159	72	44	180	452
RTOR Reduction (vph)	0	0	132	0	9	0	0	0	53	0	0	156
Lane Group Flow (vph)	528	1569	155	49	1033	0	173	159	19	44	180	296
Confl. Peds. (#/hr)							2					2
Confl. Bikes (#/hr)			1									
Heavy Vehicles (%)	10%	10%	2%	14%	18%	11%	5%	5%	15%	15%	8%	7%
Turn Type	pm+pt	NA	Perm	pm+pt	NA		Perm	NA	Perm	Perm	NA	Perm
Protected Phases	5	2		1	6			4			8	
Permitted Phases	2		2	6			4		4	8		8
Actuated Green, G (s)	74.7	65.0	65.0	51.8	45.1		31.5	31.5	31.5	31.5	31.5	31.5
Effective Green, g (s)	74.7	65.0	65.0	51.8	45.1		31.5	31.5	31.5	31.5	31.5	31.5
Actuated g/C Ratio	0.62	0.54	0.54	0.43	0.38		0.26	0.26	0.26	0.26	0.26	0.26
Clearance Time (s)	3.0	6.9	6.9	3.0	6.9		6.9	6.9	6.9	6.9	6.9	6.9
Vehicle Extension (s)	5.0	5.0	5.0	5.0	5.0		5.0	5.0	5.0	5.0	5.0	5.0
Lane Grp Cap (vph)	478	2582	830	180	1657		273	480	364	266	466	386
v/s Ratio Prot	c0.24	0.33		0.02	0.23			0.09			0.10	
v/s Ratio Perm	c0.44		0.10	0.10			0.17		0.01	0.04		c0.20
v/c Ratio	1.10	0.61	0.19	0.27	0.62		0.63	0.33	0.05	0.17	0.39	0.77
Uniform Delay, d1	28.1	18.8	14.0	20.0	30.5		39.1	35.7	33.1	34.1	36.3	40.9
Progression Factor	1.00	1.00	1.00	1.32	1.15		1.00	1.00	1.00	1.00	1.00	1.00
Incremental Delay, d2	72.8	1.1	0.5	1.6	1.7		6.5	0.9	0.1	0.6	1.1	10.4
Delay (s)	100.9	19.9	14.5	28.0	36.7		45.7	36.6	33.2	34.7	37.4	51.3
Level of Service	F	B	B	C	D		D	D	C	C	D	D
Approach Delay (s)		37.2			36.3			39.9			46.5	
Approach LOS		D			D			D			D	
<b>Intersection Summary</b>												
HCM 2000 Control Delay			38.6				HCM 2000 Level of Service			D		
HCM 2000 Volume to Capacity ratio			1.03									
Actuated Cycle Length (s)			120.0				Sum of lost time (s)			16.8		
Intersection Capacity Utilization			91.1%				ICU Level of Service			F		
Analysis Period (min)			15									

c Critical Lane Group

HCM Signalized Intersection Capacity Analysis  
102: Dixie Rd & Mayfield Rd

























2027 Future Total Conditions (Mitigation)  
AM Peak Hour

												
Movement	EBL	EBT	EBR	WBL	WBT	WBR	NBL	NBT	NBR	SBL	SBT	SBR
Lane Configurations		  			  							
Traffic Volume (vph)	528	1569	287	49	955	87	173	159	72	44	180	452
Future Volume (vph)	528	1569	287	49	955	87	173	159	72	44	180	452
Ideal Flow (vphpl)	1900	1900	1900	1900	1900	1900	1900	1900	1900	1900	1900	1900
Lane Width	3.5	3.7	3.5	3.5	3.7	3.5	3.5	3.7	3.5	3.5	3.7	3.5
Total Lost time (s)	3.0	6.9	6.9	3.0	6.9		6.9	6.9	6.9	6.9	6.9	6.9
Lane Util. Factor	1.00	0.91	1.00	1.00	0.91		1.00	1.00	1.00	1.00	1.00	1.00
Frbp, ped/bikes	1.00	1.00	0.98	1.00	1.00		1.00	1.00	1.00	1.00	1.00	0.99
Flpb, ped/bikes	1.00	1.00	1.00	1.00	1.00		1.00	1.00	1.00	1.00	1.00	1.00
Frt	1.00	1.00	0.85	1.00	0.99		1.00	1.00	0.85	1.00	1.00	0.85
Flt Protected	0.95	1.00	1.00	0.95	1.00		0.95	1.00	1.00	0.95	1.00	1.00
Satd. Flow (prot)	1623	4768	1533	1566	4411		1698	1830	1389	1552	1779	1472
Flt Permitted	0.15	1.00	1.00	0.15	1.00		0.54	1.00	1.00	0.59	1.00	1.00
Satd. Flow (perm)	253	4768	1533	248	4411		973	1830	1389	961	1779	1472
Peak-hour factor, PHF	1.00	1.00	1.00	1.00	1.00	1.00	1.00	1.00	1.00	1.00	1.00	1.00
Adj. Flow (vph)	528	1569	287	49	955	87	173	159	72	44	180	452
RTOR Reduction (vph)	0	0	116	0	8	0	0	0	56	0	0	311
Lane Group Flow (vph)	528	1569	171	49	1034	0	173	159	16	44	180	141
Confl. Peds. (#/hr)							2					2
Confl. Bikes (#/hr)			1									
Heavy Vehicles (%)	10%	10%	2%	14%	18%	11%	5%	5%	15%	15%	8%	7%
Turn Type	pm+pt	NA	Perm	pm+pt	NA		Perm	NA	Perm	Perm	NA	Perm
Protected Phases	5	2		1	6			4			8	
Permitted Phases	2		2	6			4		4	8		8
Actuated Green, G (s)	87.8	77.4	77.4	49.6	42.2		28.4	28.4	28.4	28.4	28.4	28.4
Effective Green, g (s)	87.8	77.4	77.4	49.6	42.2		28.4	28.4	28.4	28.4	28.4	28.4
Actuated g/C Ratio	0.68	0.60	0.60	0.38	0.32		0.22	0.22	0.22	0.22	0.22	0.22
Clearance Time (s)	3.0	6.9	6.9	3.0	6.9		6.9	6.9	6.9	6.9	6.9	6.9
Vehicle Extension (s)	5.0	5.0	5.0	5.0	5.0		5.0	5.0	5.0	5.0	5.0	5.0
Lane Grp Cap (vph)	619	2838	912	169	1431		212	399	303	209	388	321
v/s Ratio Prot	c0.28	0.33		0.02	0.23			0.09			0.10	
v/s Ratio Perm	c0.30		0.11	0.09			c0.18		0.01	0.05		0.10
v/c Ratio	0.85	0.55	0.19	0.29	0.72		0.82	0.40	0.05	0.21	0.46	0.44
Uniform Delay, d1	28.3	15.9	12.0	25.7	38.7		48.3	43.5	40.2	41.6	44.2	43.9
Progression Factor	1.00	1.00	1.00	1.00	1.00		1.00	1.00	1.00	1.00	1.00	1.00
Incremental Delay, d2	12.0	0.8	0.5	2.0	3.2		23.3	1.4	0.1	1.1	1.8	2.0
Delay (s)	40.3	16.6	12.4	27.7	41.9		71.6	44.9	40.3	42.7	46.0	45.9
Level of Service	D	B	B	C	D		E	D	D	D	D	D
Approach Delay (s)		21.4			41.3			55.5			45.7	
Approach LOS		C			D			E			D	
<b>Intersection Summary</b>												
HCM 2000 Control Delay			32.8			HCM 2000 Level of Service			C			
HCM 2000 Volume to Capacity ratio			0.86									
Actuated Cycle Length (s)			130.0			Sum of lost time (s)			16.8			
Intersection Capacity Utilization			91.1%			ICU Level of Service			F			
Analysis Period (min)			15									

c Critical Lane Group

HCM Signalized Intersection Capacity Analysis  
 104: Mayfield Rd & 12035 Dixie Rd Development Access

2027 Future Total Conditions  
 AM Peak Hour

												
Movement	EBL	EBT	EBR	WBL	WBT	WBR	NBL	NBT	NBR	SBL	SBT	SBR
Lane Configurations		  			 			 			 	
Traffic Volume (vph)	98	1587	0	0	1056	26	0	0	0	3	0	35
Future Volume (vph)	98	1587	0	0	1056	26	0	0	0	3	0	35
Ideal Flow (vphpl)	1900	1900	1900	1900	1900	1900	1900	1900	1900	1900	1900	1900
Lane Width	3.5	3.7	3.5	3.5	3.7	3.5	3.5	3.7	3.5	3.5	3.7	3.5
Total Lost time (s)	6.9	6.9			6.9						6.9	
Lane Util. Factor	1.00	0.91			0.95						1.00	
Frt	1.00	1.00			1.00						0.88	
Flt Protected	0.95	1.00			1.00						1.00	
Satd. Flow (prot)	1785	4768			3119						1676	
Flt Permitted	0.26	1.00			1.00						0.97	
Satd. Flow (perm)	486	4768			3119						1634	
Peak-hour factor, PHF	1.00	1.00	1.00	1.00	1.00	1.00	1.00	1.00	1.00	1.00	1.00	1.00
Adj. Flow (vph)	98	1587	0	0	1056	26	0	0	0	3	0	35
RTOR Reduction (vph)	0	0	0	0	0	0	0	0	0	0	33	0
Lane Group Flow (vph)	98	1587	0	0	1082	0	0	0	0	0	5	0
Heavy Vehicles (%)	0%	10%	0%	0%	17%	0%	0%	0%	0%	0%	0%	0%
Turn Type	Perm	NA	Perm	Perm	NA					Perm	NA	
Protected Phases		2			6			8			4	
Permitted Phases	2		2	6			8			4		
Actuated Green, G (s)	100.7	100.7			100.7						5.5	
Effective Green, g (s)	100.7	100.7			100.7						5.5	
Actuated g/C Ratio	0.84	0.84			0.84						0.05	
Clearance Time (s)	6.9	6.9			6.9						6.9	
Vehicle Extension (s)	5.0	5.0			5.0						5.0	
Lane Grp Cap (vph)	407	4001			2617						74	
v/s Ratio Prot		0.33			c0.35							
v/s Ratio Perm	0.20										c0.00	
v/c Ratio	0.24	0.40			0.41						0.06	
Uniform Delay, d1	1.9	2.3			2.4						54.8	
Progression Factor	4.02	4.03			1.00						1.00	
Incremental Delay, d2	1.2	0.2			0.5						0.7	
Delay (s)	9.0	9.6			2.9						55.5	
Level of Service	A	A			A						E	
Approach Delay (s)		9.6			2.9			0.0			55.5	
Approach LOS		A			A			A			E	
<b>Intersection Summary</b>												
HCM 2000 Control Delay			7.6		HCM 2000 Level of Service					A		
HCM 2000 Volume to Capacity ratio			0.39									
Actuated Cycle Length (s)			120.0		Sum of lost time (s)				13.8			
Intersection Capacity Utilization			64.6%		ICU Level of Service					C		
Analysis Period (min)			15									

c Critical Lane Group

HCM Unsignalized Intersection Capacity Analysis  
 103: Mayfield Rd & Site Access

2027 Future Total Conditions  
 AM Peak Hour

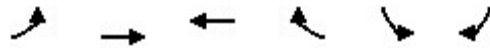

Movement	EBL	EBT	WBT	WBR	SBL	SBR
Lane Configurations		↑↑↑	↑↑		↘	
Traffic Volume (veh/h)	0	1590	1074	0	7	8
Future Volume (Veh/h)	0	1590	1074	0	7	8
Sign Control		Free	Free		Stop	
Grade		0%	0%		0%	
Peak Hour Factor	1.00	1.00	1.00	1.00	1.00	1.00
Hourly flow rate (vph)	0	1590	1074	0	7	8
<b>Pedestrians</b>						
Lane Width (m)						
Walking Speed (m/s)						
Percent Blockage						
Right turn flare (veh)						
Median type		None	None			
Median storage (veh)						
Upstream signal (m)	387					
pX, platoon unblocked	0.89				0.89	0.89
vC, conflicting volume	1074				1604	537
vC1, stage 1 conf vol						
vC2, stage 2 conf vol						
vCu, unblocked vol	841				1435	238
tC, single (s)	4.1				8.8	8.9
tC, 2 stage (s)						
tF (s)	2.2				4.5	4.3
p0 queue free %	100				85	98
cM capacity (veh/h)	717				46	476
Direction, Lane #	EB 1	EB 2	EB 3	WB 1	WB 2	SB 1
Volume Total	318	636	636	716	358	15
Volume Left	0	0	0	0	0	7
Volume Right	0	0	0	0	0	8
cSH	717	1700	1700	1700	1700	89
Volume to Capacity	0.00	0.37	0.37	0.42	0.21	0.17
Queue Length 95th (m)	0.0	0.0	0.0	0.0	0.0	4.0
Control Delay (s)	0.0	0.0	0.0	0.0	0.0	53.6
Lane LOS	F					
Approach Delay (s)	0.0			0.0		53.6
Approach LOS	F					
<b>Intersection Summary</b>						
Average Delay	0.3					
Intersection Capacity Utilization	40.7%					
ICU Level of Service	A					
Analysis Period (min)	15					

HCM Unsignalized Intersection Capacity Analysis  
 103: Mayfield Rd & Site Access



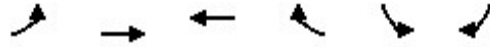





















2027 Future Total Conditions (Mitigation)  
 AM Peak Hour



Movement	EBL	EBT	WBT	WBR	SBL	SBR
Lane Configurations		↑↑↑	↑↑		↘	
Traffic Volume (veh/h)	0	1590	1074	0	7	8
Future Volume (Veh/h)	0	1590	1074	0	7	8
Sign Control		Free	Free		Stop	
Grade		0%	0%		0%	
Peak Hour Factor	1.00	1.00	1.00	1.00	1.00	1.00
Hourly flow rate (vph)	0	1590	1074	0	7	8
Pedestrians						
Lane Width (m)						
Walking Speed (m/s)						
Percent Blockage						
Right turn flare (veh)						
Median type						
		TWLTL	TWLTL			
Median storage veh)		2	2			
Upstream signal (m)			387			
pX, platoon unblocked	0.89				0.89	0.89
vC, conflicting volume	1074				1604	537
vC1, stage 1 conf vol					1074	
vC2, stage 2 conf vol					530	
vCu, unblocked vol	841				1435	238
tC, single (s)	4.1				8.8	8.9
tC, 2 stage (s)					7.8	
tF (s)	2.2				4.5	4.3
p0 queue free %	100				96	98
cM capacity (veh/h)	717				164	476
Direction, Lane #	EB 1	EB 2	EB 3	WB 1	WB 2	SB 1
Volume Total	318	636	636	716	358	15
Volume Left	0	0	0	0	0	7
Volume Right	0	0	0	0	0	8
cSH	717	1700	1700	1700	1700	253
Volume to Capacity	0.00	0.37	0.37	0.42	0.21	0.06
Queue Length 95th (m)	0.0	0.0	0.0	0.0	0.0	1.3
Control Delay (s)	0.0	0.0	0.0	0.0	0.0	20.2
Lane LOS						C
Approach Delay (s)	0.0			0.0		20.2
Approach LOS						C
Intersection Summary						
Average Delay			0.1			
Intersection Capacity Utilization			40.7%		ICU Level of Service	A
Analysis Period (min)			15			

HCM Signalized Intersection Capacity Analysis  
101: Bramalea Rd & Mayfield Rd

2027 Future Total Conditions  
PM Peak Hour

												
Movement	EBL	EBT	EBR	WBL	WBT	WBR	NBL	NBT	NBR	SBL	SBT	SBR
Lane Configurations												
Traffic Volume (vph)	144	974	146	121	1043	25	267	176	61	27	107	93
Future Volume (vph)	144	974	146	121	1043	25	267	176	61	27	107	93
Ideal Flow (vphpl)	1900	1900	1900	1900	1900	1900	1900	1900	1900	1900	1900	1900
Lane Width	3.5	3.7	3.5	3.5	3.7	3.5	3.5	3.7	3.5	3.5	3.7	3.5
Total Lost time (s)	3.0	7.2	7.2	7.2	7.2	7.2	7.1	7.1	7.1	3.0	7.1	
Lane Util. Factor	1.00	0.91	1.00	1.00	0.91	1.00	1.00	1.00	1.00	1.00	0.95	
Frbp, ped/bikes	1.00	1.00	0.99	1.00	1.00	0.97	1.00	1.00	0.99	1.00	0.99	
Flpb, ped/bikes	1.00	1.00	1.00	1.00	1.00	1.00	1.00	1.00	1.00	1.00	1.00	
Frt	1.00	1.00	0.85	1.00	1.00	0.85	1.00	1.00	0.85	1.00	0.93	
Flt Protected	0.95	1.00	1.00	0.95	1.00	1.00	0.95	1.00	1.00	0.95	1.00	
Satd. Flow (prot)	1767	4683	1545	1784	4856	1480	1766	1921	1577	1785	3282	
Flt Permitted	0.20	1.00	1.00	0.28	1.00	1.00	0.63	1.00	1.00	0.56	1.00	
Satd. Flow (perm)	372	4683	1545	529	4856	1480	1164	1921	1577	1048	3282	
Peak-hour factor, PHF	1.00	1.00	1.00	1.00	1.00	1.00	1.00	1.00	1.00	1.00	1.00	1.00
Adj. Flow (vph)	144	974	146	121	1043	25	267	176	61	27	107	93
RTOR Reduction (vph)	0	0	68	0	0	14	0	0	44	0	61	0
Lane Group Flow (vph)	144	974	78	121	1043	11	267	176	17	27	139	0
Confl. Peds. (#/hr)	6		2	2		6	1					1
Confl. Bikes (#/hr)									1			
Heavy Vehicles (%)	1%	12%	2%	0%	8%	5%	1%	0%	0%	0%	1%	5%
Turn Type	pm+pt	NA	Perm	Perm	NA	Perm	Perm	NA	Perm	pm+pt	NA	
Protected Phases	5	2			6			4		3	8	
Permitted Phases	2		2	6		6	4		4	8		
Actuated Green, G (s)	63.1	63.1	63.1	53.0	53.0	53.0	33.7	33.7	33.7	40.5	40.5	
Effective Green, g (s)	63.1	63.1	63.1	53.0	53.0	53.0	33.7	33.7	33.7	40.5	40.5	
Actuated g/C Ratio	0.54	0.54	0.54	0.45	0.45	0.45	0.29	0.29	0.29	0.34	0.34	
Clearance Time (s)	3.0	7.2	7.2	7.2	7.2	7.2	7.1	7.1	7.1	3.0	7.1	
Vehicle Extension (s)	5.0	5.0	5.0	5.0	5.0	5.0	5.0	5.0	5.0	5.0	5.0	
Lane Grp Cap (vph)	283	2506	826	237	2182	665	332	549	450	383	1127	
v/s Ratio Prot	c0.03	0.21			0.21			0.09		0.00	c0.04	
v/s Ratio Perm	c0.24		0.05	0.23		0.01	c0.23		0.01	0.02		
v/c Ratio	0.51	0.39	0.09	0.51	0.48	0.02	0.80	0.32	0.04	0.07	0.12	
Uniform Delay, d1	14.9	16.1	13.4	23.2	22.8	18.0	39.0	33.1	30.4	25.9	26.5	
Progression Factor	1.00	1.00	1.00	1.00	1.00	1.00	1.00	1.00	1.00	1.00	1.00	
Incremental Delay, d2	3.0	0.5	0.2	7.7	0.8	0.0	14.9	0.7	0.1	0.2	0.1	
Delay (s)	17.9	16.5	13.6	30.8	23.5	18.0	53.9	33.8	30.5	26.1	26.6	
Level of Service	B	B	B	C	C	B	D	C	C	C	C	
Approach Delay (s)		16.4			24.1			44.1			26.6	
Approach LOS		B			C			D			C	
<b>Intersection Summary</b>												
HCM 2000 Control Delay			24.4			HCM 2000 Level of Service				C		
HCM 2000 Volume to Capacity ratio			0.61									
Actuated Cycle Length (s)			117.9			Sum of lost time (s)				20.3		
Intersection Capacity Utilization			99.8%			ICU Level of Service				F		
Analysis Period (min)			15									

c Critical Lane Group

HCM Signalized Intersection Capacity Analysis  
102: Dixie Rd & Mayfield Rd



























2027 Future Total Conditions  
PM Peak Hour

Movement	EBL	EBT	EBR	WBL	WBT	WBR	NBL	NBT	NBR	SBL	SBT	SBR
Lane Configurations												
Traffic Volume (vph)	508	1396	248	86	1554	65	232	235	66	79	196	623
Future Volume (vph)	508	1396	248	86	1554	65	232	235	66	79	196	623
Ideal Flow (vphpl)	1900	1900	1900	1900	1900	1900	1900	1900	1900	1900	1900	1900
Lane Width	3.5	3.7	3.5	3.5	3.7	3.5	3.5	3.7	3.5	3.5	3.7	3.5
Total Lost time (s)	3.0	6.9	6.9	3.0	6.9		6.9	6.9	6.9	6.9	6.9	6.9
Lane Util. Factor	1.00	0.91	1.00	1.00	0.91		1.00	1.00	1.00	1.00	1.00	1.00
Frpb, ped/bikes	1.00	1.00	1.00	1.00	1.00		1.00	1.00	0.99	1.00	1.00	0.98
Flpb, ped/bikes	1.00	1.00	1.00	1.00	1.00		1.00	1.00	1.00	1.00	1.00	1.00
Frt	1.00	1.00	0.85	1.00	0.99		1.00	1.00	0.85	1.00	1.00	0.85
Flt Protected	0.95	1.00	1.00	0.95	1.00		0.95	1.00	1.00	0.95	1.00	1.00
Satd. Flow (prot)	1580	4683	1581	1684	4847		1763	1865	1432	1698	1883	1440
Flt Permitted	0.09	1.00	1.00	0.17	1.00		0.59	1.00	1.00	0.54	1.00	1.00
Satd. Flow (perm)	154	4683	1581	303	4847		1097	1865	1432	961	1883	1440
Peak-hour factor, PHF	1.00	1.00	1.00	1.00	1.00	1.00	1.00	1.00	1.00	1.00	1.00	1.00
Adj. Flow (vph)	508	1396	248	86	1554	65	232	235	66	79	196	623
RTOR Reduction (vph)	0	0	132	0	4	0	0	0	44	0	0	187
Lane Group Flow (vph)	508	1396	116	86	1615	0	232	235	22	79	196	436
Confl. Peds. (#/hr)	5					5	4		2	2		4
Confl. Bikes (#/hr)												3
Heavy Vehicles (%)	13%	12%	1%	6%	7%	18%	1%	3%	10%	5%	2%	9%
Turn Type	pm+pt	NA	Perm	pm+pt	NA		Perm	NA	Perm	Perm	NA	Perm
Protected Phases	5	2		1	6			4			8	
Permitted Phases	2		2	6			4		4	8		8
Actuated Green, G (s)	65.4	56.3	56.3	46.2	40.1		40.8	40.8	40.8	40.8	40.8	40.8
Effective Green, g (s)	65.4	56.3	56.3	46.2	40.1		40.8	40.8	40.8	40.8	40.8	40.8
Actuated g/C Ratio	0.55	0.47	0.47	0.39	0.33		0.34	0.34	0.34	0.34	0.34	0.34
Clearance Time (s)	3.0	6.9	6.9	3.0	6.9		6.9	6.9	6.9	6.9	6.9	6.9
Vehicle Extension (s)	5.0	5.0	5.0	5.0	5.0		5.0	5.0	5.0	5.0	5.0	5.0
Lane Grp Cap (vph)	348	2197	741	186	1619		372	634	486	326	640	489
v/s Ratio Prot	c0.27	0.30		0.02	0.33			0.13			0.10	
v/s Ratio Perm	c0.52		0.07	0.15			0.21		0.02	0.08		c0.30
v/c Ratio	1.46	0.64	0.16	0.46	1.00		0.62	0.37	0.05	0.24	0.31	0.89
Uniform Delay, d1	37.7	24.1	18.3	23.9	39.9		33.2	29.9	26.6	28.5	29.2	37.5
Progression Factor	1.00	1.00	1.00	0.65	0.88		1.00	1.00	1.00	1.00	1.00	1.00
Incremental Delay, d2	222.2	1.4	0.5	3.1	19.6		4.6	0.8	0.1	0.8	0.6	19.3
Delay (s)	259.9	25.5	18.7	18.6	54.7		37.7	30.7	26.6	29.3	29.7	56.8
Level of Service	F	C	B	B	D		D	C	C	C	C	E
Approach Delay (s)		80.1			52.9			33.2			48.5	
Approach LOS		F			D			C			D	
<b>Intersection Summary</b>												
HCM 2000 Control Delay			61.2			HCM 2000 Level of Service			E			
HCM 2000 Volume to Capacity ratio			1.27									
Actuated Cycle Length (s)			120.0			Sum of lost time (s)			16.8			
Intersection Capacity Utilization			110.3%			ICU Level of Service			H			
Analysis Period (min)			15									

c Critical Lane Group

HCM Signalized Intersection Capacity Analysis  
102: Dixie Rd & Mayfield Rd

























2027 Future Total Conditions (Mitigation)  
PM Peak Hour

												
Movement	EBL	EBT	EBR	WBL	WBT	WBR	NBL	NBT	NBR	SBL	SBT	SBR
Lane Configurations		  			  							
Traffic Volume (vph)	508	1396	248	86	1554	65	232	235	66	79	196	623
Future Volume (vph)	508	1396	248	86	1554	65	232	235	66	79	196	623
Ideal Flow (vphpl)	1900	1900	1900	1900	1900	1900	1900	1900	1900	1900	1900	1900
Lane Width	3.5	3.7	3.5	3.5	3.7	3.5	3.5	3.7	3.5	3.5	3.7	3.5
Total Lost time (s)	3.0	6.9	6.9	3.0	6.9		6.9	6.9	6.9	6.9	6.9	6.9
Lane Util. Factor	1.00	0.91	1.00	1.00	0.91		1.00	1.00	1.00	1.00	1.00	1.00
Frbp, ped/bikes	1.00	1.00	1.00	1.00	1.00		1.00	1.00	0.99	1.00	1.00	0.98
Flpb, ped/bikes	1.00	1.00	1.00	1.00	1.00		1.00	1.00	1.00	1.00	1.00	1.00
Frt	1.00	1.00	0.85	1.00	0.99		1.00	1.00	0.85	1.00	1.00	0.85
Flt Protected	0.95	1.00	1.00	0.95	1.00		0.95	1.00	1.00	0.95	1.00	1.00
Satd. Flow (prot)	1580	4683	1581	1684	4846		1762	1865	1432	1698	1883	1438
Flt Permitted	0.08	1.00	1.00	0.18	1.00		0.53	1.00	1.00	0.46	1.00	1.00
Satd. Flow (perm)	126	4683	1581	321	4846		979	1865	1432	824	1883	1438
Peak-hour factor, PHF	1.00	1.00	1.00	1.00	1.00	1.00	1.00	1.00	1.00	1.00	1.00	1.00
Adj. Flow (vph)	508	1396	248	86	1554	65	232	235	66	79	196	623
RTOR Reduction (vph)	0	0	108	0	3	0	0	0	49	0	0	333
Lane Group Flow (vph)	508	1396	140	86	1616	0	232	235	17	79	196	290
Confl. Peds. (#/hr)	5					5	4		2	2		4
Confl. Bikes (#/hr)												3
Heavy Vehicles (%)	13%	12%	1%	6%	7%	18%	1%	3%	10%	5%	2%	9%
Turn Type	pm+pt	NA	Perm	pm+pt	NA		Perm	NA	Perm	Perm	NA	Perm
Protected Phases	5	2		1	6			4			8	
Permitted Phases	2		2	6			4		4	8		8
Actuated Green, G (s)	96.9	84.8	84.8	59.0	49.9		39.3	39.3	39.3	39.3	39.3	39.3
Effective Green, g (s)	96.9	84.8	84.8	59.0	49.9		39.3	39.3	39.3	39.3	39.3	39.3
Actuated g/C Ratio	0.65	0.57	0.57	0.39	0.33		0.26	0.26	0.26	0.26	0.26	0.26
Clearance Time (s)	3.0	6.9	6.9	3.0	6.9		6.9	6.9	6.9	6.9	6.9	6.9
Vehicle Extension (s)	5.0	5.0	5.0	5.0	5.0		5.0	5.0	5.0	5.0	5.0	5.0
Lane Grp Cap (vph)	507	2647	893	208	1612		256	488	375	215	493	376
v/s Ratio Prot	c0.29	0.30		0.02	0.33			0.13			0.10	
v/s Ratio Perm	c0.35		0.09	0.14			c0.24		0.01	0.10		0.20
v/c Ratio	1.00	0.53	0.16	0.41	1.00		0.91	0.48	0.05	0.37	0.40	0.77
Uniform Delay, d1	46.1	20.2	15.6	29.1	50.0		53.6	46.7	41.3	45.2	45.6	51.2
Progression Factor	1.00	1.00	1.00	1.00	1.00		1.00	1.00	1.00	1.00	1.00	1.00
Incremental Delay, d2	40.5	0.8	0.4	2.8	23.1		33.9	1.6	0.1	2.2	1.1	11.0
Delay (s)	86.5	20.9	15.9	31.9	73.1		87.5	48.3	41.5	47.4	46.7	62.2
Level of Service	F	C	B	C	E		F	D	D	D	D	E
Approach Delay (s)		35.8			71.0			64.5			57.5	
Approach LOS		D			E			E			E	
<b>Intersection Summary</b>												
HCM 2000 Control Delay			53.8			HCM 2000 Level of Service			D			
HCM 2000 Volume to Capacity ratio			0.99									
Actuated Cycle Length (s)			150.0			Sum of lost time (s)			16.8			
Intersection Capacity Utilization			110.3%			ICU Level of Service			H			
Analysis Period (min)			15									

c Critical Lane Group

HCM Signalized Intersection Capacity Analysis  
 104: Mayfield Rd & 12035 Dixie Rd Development Access

2027 Future Total Conditions  
 PM Peak Hour

													
Movement	EBL	EBT	EBR	WBL	WBT	WBR	NBL	NBT	NBR	SBL	SBT	SBR	
Lane Configurations		  			 				 		 		
Traffic Volume (vph)	43	1499	0	0	1601	3	0	0	0	27	0	104	
Future Volume (vph)	43	1499	0	0	1601	3	0	0	0	27	0	104	
Ideal Flow (vphpl)	1900	1900	1900	1900	1900	1900	1900	1900	1900	1900	1900	1900	
Lane Width	3.5	3.7	3.5	3.5	3.7	3.5	3.5	3.7	3.5	3.5	3.7	3.5	
Total Lost time (s)	6.9	6.9			6.9							6.9	
Lane Util. Factor	1.00	0.91			0.95							1.00	
Frt	1.00	1.00			1.00							0.89	
Flt Protected	0.95	1.00			1.00							0.99	
Satd. Flow (prot)	1785	4683			3411							1698	
Flt Permitted	0.13	1.00			1.00							0.93	
Satd. Flow (perm)	235	4683			3411							1592	
Peak-hour factor, PHF	1.00	1.00	1.00	1.00	1.00	1.00	1.00	1.00	1.00	1.00	1.00	1.00	
Adj. Flow (vph)	43	1499	0	0	1601	3	0	0	0	27	0	104	
RTOR Reduction (vph)	0	0	0	0	0	0	0	0	0	0	31	0	
Lane Group Flow (vph)	43	1499	0	0	1604	0	0	0	0	0	100	0	
Heavy Vehicles (%)	0%	12%	0%	0%	7%	0%	0%	0%	0%	0%	0%	0%	
Turn Type	Perm	NA	Perm	Perm	NA						Perm	NA	
Protected Phases		2			6			8				4	
Permitted Phases	2		2	6			8			4			
Actuated Green, G (s)	91.7	91.7			91.7							14.5	
Effective Green, g (s)	91.7	91.7			91.7							14.5	
Actuated g/C Ratio	0.76	0.76			0.76							0.12	
Clearance Time (s)	6.9	6.9			6.9							6.9	
Vehicle Extension (s)	5.0	5.0			5.0							5.0	
Lane Grp Cap (vph)	179	3578			2606							192	
v/s Ratio Prot		0.32			c0.47								
v/s Ratio Perm	0.18											c0.06	
v/c Ratio	0.24	0.42			0.62							0.52	
Uniform Delay, d1	4.1	4.9			6.3							49.5	
Progression Factor	1.81	1.59			1.00							1.00	
Incremental Delay, d2	2.6	0.3			1.1							4.8	
Delay (s)	10.0	8.1			7.4							54.3	
Level of Service	A	A			A							D	
Approach Delay (s)		8.2			7.4			0.0				54.3	
Approach LOS		A			A			A				D	
<b>Intersection Summary</b>													
HCM 2000 Control Delay			9.6									HCM 2000 Level of Service	A
HCM 2000 Volume to Capacity ratio			0.60										
Actuated Cycle Length (s)			120.0									Sum of lost time (s)	13.8
Intersection Capacity Utilization			63.8%									ICU Level of Service	B
Analysis Period (min)			15										

c Critical Lane Group

HCM Unsignalized Intersection Capacity Analysis  
 103: Mayfield Rd & Site Access

2027 Future Total Conditions  
 PM Peak Hour

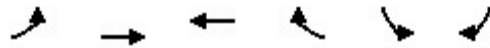

Movement	EBL	EBT	WBT	WBR	SBL	SBR
Lane Configurations		↑↑↑	↑↑		↘	
Traffic Volume (veh/h)	8	1518	1604	7	0	0
Future Volume (Veh/h)	8	1518	1604	7	0	0
Sign Control		Free	Free		Stop	
Grade		0%	0%		0%	
Peak Hour Factor	1.00	1.00	1.00	1.00	1.00	1.00
Hourly flow rate (vph)	8	1518	1604	7	0	0
Pedestrians						
Lane Width (m)						
Walking Speed (m/s)						
Percent Blockage						
Right turn flare (veh)						
Median type		None	None			
Median storage (veh)						
Upstream signal (m)			387			
pX, platoon unblocked	0.80				0.80	0.80
vC, conflicting volume	1611				2130	806
vC1, stage 1 conf vol						
vC2, stage 2 conf vol						
vCu, unblocked vol	1272				1917	271
tC, single (s)	6.1				6.8	6.9
tC, 2 stage (s)						
tF (s)	3.2				3.5	3.3
p0 queue free %	95				100	100
cM capacity (veh/h)	175				47	590
Direction, Lane #	EB 1	EB 2	EB 3	WB 1	WB 2	SB 1
Volume Total	312	607	607	1069	542	0
Volume Left	8	0	0	0	0	0
Volume Right	0	0	0	0	7	0
cSH	175	1700	1700	1700	1700	1700
Volume to Capacity	0.05	0.36	0.36	0.63	0.32	0.00
Queue Length 95th (m)	1.0	0.0	0.0	0.0	0.0	0.0
Control Delay (s)	2.1	0.0	0.0	0.0	0.0	0.0
Lane LOS	A					A
Approach Delay (s)	0.4			0.0		0.0
Approach LOS						A
Intersection Summary						
Average Delay			0.2			
Intersection Capacity Utilization			47.9%		ICU Level of Service	A
Analysis Period (min)			15			

Queues  
101: Bramalea Rd & Mayfield Rd

2027 Future Total Conditions  
AM Peak Hour



Lane Group	EBL	EBT	EBR	WBL	WBT	WBR	NBL	NBT	NBR	SBL	SBT
Lane Group Flow (vph)	291	1073	224	112	763	25	68	147	61	49	375
v/c Ratio	0.60	0.37	0.22	0.50	0.33	0.04	0.47	0.52	0.21	0.17	0.42
Control Delay	14.2	10.4	1.9	27.3	15.0	0.1	50.3	46.1	6.7	27.4	18.6
Queue Delay	0.0	0.0	0.0	0.0	0.0	0.0	0.0	0.0	0.0	0.0	0.0
Total Delay	14.2	10.4	1.9	27.3	15.0	0.1	50.3	46.1	6.7	27.4	18.6
Queue Length 50th (m)	19.8	33.1	0.0	12.8	28.4	0.0	11.4	25.0	0.0	6.5	16.2
Queue Length 95th (m)	36.7	48.3	8.8	33.7	41.4	0.0	23.8	42.3	6.6	14.3	27.5
Internal Link Dist (m)		182.8			347.4			479.0			343.8
Turn Bay Length (m)	180.0		110.0	80.0		100.0	100.0			110.0	
Base Capacity (vph)	485	2925	1030	225	2329	644	486	949	771	293	2129
Starvation Cap Reductn	0	0	0	0	0	0	0	0	0	0	0
Spillback Cap Reductn	0	0	0	0	0	0	0	0	0	0	0
Storage Cap Reductn	0	0	0	0	0	0	0	0	0	0	0
Reduced v/c Ratio	0.60	0.37	0.22	0.50	0.33	0.04	0.14	0.15	0.08	0.17	0.18

Intersection Summary

Queues  
102: Dixie Rd & Mayfield Rd

2027 Future Total Conditions  
AM Peak Hour



Lane Group	EBL	EBT	EBR	WBL	WBT	NBL	NBT	NBR	SBL	SBT	SBR
Lane Group Flow (vph)	528	1569	287	49	1042	173	159	72	44	180	452
v/c Ratio	1.08	0.60	0.30	0.23	0.63	0.63	0.33	0.17	0.17	0.39	0.83
Control Delay	91.3	22.4	3.3	18.1	36.5	47.5	35.1	4.0	30.9	36.4	34.4
Queue Delay	0.0	0.0	0.0	0.0	0.0	0.0	0.0	0.0	0.0	0.0	0.0
Total Delay	91.3	22.4	3.3	18.1	36.5	47.5	35.1	4.0	30.9	36.4	34.4
Queue Length 50th (m)	~99.6	85.8	0.0	5.0	77.2	33.1	27.8	0.0	7.3	32.0	52.1
Queue Length 95th (m)	#205.9	123.9	14.6	13.5	91.8	46.4	37.5	5.9	13.7	42.2	76.3
Internal Link Dist (m)		507.8			328.1		418.0			489.9	
Turn Bay Length (m)	170.0		100.0	150.0		120.0		50.0	80.0		170.0
Base Capacity (vph)	488	2605	967	209	1665	401	703	589	389	683	695
Starvation Cap Reductn	0	0	0	0	0	0	0	0	0	0	0
Spillback Cap Reductn	0	0	0	0	0	0	0	0	0	0	0
Storage Cap Reductn	0	0	0	0	0	0	0	0	0	0	0
Reduced v/c Ratio	1.08	0.60	0.30	0.23	0.63	0.43	0.23	0.12	0.11	0.26	0.65

Intersection Summary

~ Volume exceeds capacity, queue is theoretically infinite.

Queue shown is maximum after two cycles.

# 95th percentile volume exceeds capacity, queue may be longer.

Queue shown is maximum after two cycles.

Queues  
102: Dixie Rd & Mayfield Rd

2027 Future Total Conditions (Mitigation)  
AM Peak Hour



Lane Group	EBL	EBT	EBR	WBL	WBT	NBL	NBT	NBR	SBL	SBT	SBR
Lane Group Flow (vph)	528	1569	287	49	1042	173	159	72	44	180	452
v/c Ratio	0.84	0.55	0.28	0.25	0.72	0.82	0.40	0.20	0.21	0.46	0.72
Control Delay	40.6	18.4	2.6	16.0	41.8	75.2	44.6	6.5	40.6	46.5	13.2
Queue Delay	0.0	0.0	0.0	0.0	0.0	0.0	0.0	0.0	0.0	0.0	0.0
Total Delay	40.6	18.4	2.6	16.0	41.8	75.2	44.6	6.5	40.6	46.5	13.2
Queue Length 50th (m)	87.5	79.1	0.0	3.1	78.5	39.3	32.5	0.0	8.6	37.4	10.5
Queue Length 95th (m)	#178.8	117.6	13.3	9.0	93.8	57.5	45.4	8.2	16.5	51.2	39.0
Internal Link Dist (m)		507.8			328.1		418.0			489.9	
Turn Bay Length (m)	170.0		100.0	150.0		120.0		50.0	80.0		170.0
Base Capacity (vph)	627	2862	1034	195	1439	336	633	535	332	615	769
Starvation Cap Reductn	0	0	0	0	0	0	0	0	0	0	0
Spillback Cap Reductn	0	0	0	0	0	0	0	0	0	0	0
Storage Cap Reductn	0	0	0	0	0	0	0	0	0	0	0
Reduced v/c Ratio	0.84	0.55	0.28	0.25	0.72	0.51	0.25	0.13	0.13	0.29	0.59

Intersection Summary

# 95th percentile volume exceeds capacity, queue may be longer.  
Queue shown is maximum after two cycles.

Queues

2027 Future Total Conditions

104: Mayfield Rd & 12035 Dixie Rd Development Access

AM Peak Hour













Lane Group	EBL	EBT	WBT	SBT
Lane Group Flow (vph)	98	1587	1082	38
v/c Ratio	0.23	0.38	0.39	0.25
Control Delay	11.2	9.4	2.8	22.5
Queue Delay	0.0	0.0	0.0	0.0
Total Delay	11.2	9.4	2.8	22.5
Queue Length 50th (m)	7.9	56.0	26.7	0.6
Queue Length 95th (m)	m31.3	125.6	38.9	10.4
Internal Link Dist (m)		328.1	608.7	157.9
Turn Bay Length (m)	50.0			
Base Capacity (vph)	431	4219	2760	635
Starvation Cap Reductn	0	0	0	0
Spillback Cap Reductn	0	0	0	0
Storage Cap Reductn	0	0	0	0
Reduced v/c Ratio	0.23	0.38	0.39	0.06

Intersection Summary

m Volume for 95th percentile queue is metered by upstream signal.

Queues  
101: Bramalea Rd & Mayfield Rd

2027 Future Total Conditions  
PM Peak Hour

											
Lane Group	EBL	EBT	EBR	WBL	WBT	WBR	NBL	NBT	NBR	SBL	SBT
Lane Group Flow (vph)	144	974	146	121	1043	25	267	176	61	27	200
v/c Ratio	0.48	0.39	0.16	0.50	0.47	0.04	0.80	0.32	0.12	0.06	0.17
Control Delay	21.2	18.5	3.6	37.2	25.5	0.1	56.1	33.6	3.6	21.2	13.1
Queue Delay	0.0	0.0	0.0	0.0	0.0	0.0	0.0	0.0	0.0	0.0	0.0
Total Delay	21.2	18.5	3.6	37.2	25.5	0.1	56.1	33.6	3.6	21.2	13.1
Queue Length 50th (m)	15.0	46.5	0.0	19.3	59.8	0.0	54.1	30.3	0.0	3.5	7.9
Queue Length 95th (m)	32.0	72.0	10.9	46.8	88.4	0.0	83.1	46.8	5.3	8.5	14.8
Internal Link Dist (m)		182.8			347.4			479.0			343.8
Turn Bay Length (m)	180.0		110.0	80.0		100.0	100.0			110.0	
Base Capacity (vph)	299	2529	901	240	2199	713	517	853	745	433	1787
Starvation Cap Reductn	0	0	0	0	0	0	0	0	0	0	0
Spillback Cap Reductn	0	0	0	0	0	0	0	0	0	0	0
Storage Cap Reductn	0	0	0	0	0	0	0	0	0	0	0
Reduced v/c Ratio	0.48	0.39	0.16	0.50	0.47	0.04	0.52	0.21	0.08	0.06	0.11
Intersection Summary											

Queues  
102: Dixie Rd & Mayfield Rd

2027 Future Total Conditions  
PM Peak Hour



Lane Group	EBL	EBT	EBR	WBL	WBT	NBL	NBT	NBR	SBL	SBT	SBR
Lane Group Flow (vph)	508	1396	248	86	1619	232	235	66	79	196	623
v/c Ratio	1.44	0.63	0.28	0.39	1.00	0.62	0.37	0.12	0.24	0.31	0.92
Control Delay	241.6	27.1	3.6	13.7	55.1	40.0	30.5	2.8	28.5	29.2	40.0
Queue Delay	0.0	0.0	0.0	0.0	0.0	0.0	0.0	0.0	0.0	0.0	0.0
Total Delay	241.6	27.1	3.6	13.7	55.1	40.0	30.5	2.8	28.5	29.2	40.0
Queue Length 50th (m)	~152.0	90.5	0.0	9.0	128.3	39.0	35.6	0.0	11.4	29.0	73.6
Queue Length 95th (m)	#213.2	106.4	13.7	m10.3	#161.1	62.9	54.1	4.8	22.2	45.3	#139.8
Internal Link Dist (m)		507.8			328.1		418.0			489.9	
Turn Bay Length (m)	170.0		100.0	150.0		120.0		50.0	80.0		170.0
Base Capacity (vph)	353	2219	879	218	1623	421	716	605	368	723	727
Starvation Cap Reductn	0	0	0	0	0	0	0	0	0	0	0
Spillback Cap Reductn	0	0	0	0	0	0	0	0	0	0	0
Storage Cap Reductn	0	0	0	0	0	0	0	0	0	0	0
Reduced v/c Ratio	1.44	0.63	0.28	0.39	1.00	0.55	0.33	0.11	0.21	0.27	0.86

Intersection Summary

~ Volume exceeds capacity, queue is theoretically infinite.

Queue shown is maximum after two cycles.

# 95th percentile volume exceeds capacity, queue may be longer.

Queue shown is maximum after two cycles.

m Volume for 95th percentile queue is metered by upstream signal.

Queues  
102: Dixie Rd & Mayfield Rd

2027 Future Total Conditions (Mitigation)  
PM Peak Hour



Lane Group	EBL	EBT	EBR	WBL	WBT	NBL	NBT	NBR	SBL	SBT	SBR
Lane Group Flow (vph)	508	1396	248	86	1619	232	235	66	79	196	623
v/c Ratio	1.00	0.53	0.25	0.40	1.00	0.91	0.48	0.15	0.37	0.40	0.88
Control Delay	81.6	22.0	2.6	21.2	72.5	89.3	49.2	7.6	48.6	46.9	28.2
Queue Delay	0.0	0.0	0.0	0.0	0.0	0.0	0.0	0.0	0.0	0.0	0.0
Total Delay	81.6	22.0	2.6	21.2	72.5	89.3	49.2	7.6	48.6	46.9	28.2
Queue Length 50th (m)	~138.0	89.4	0.0	8.1	~163.2	60.3	53.3	0.0	17.3	43.4	50.9
Queue Length 95th (m)	#212.9	105.1	12.1	15.2	#196.0	#97.8	75.0	9.1	31.2	62.6	104.6
Internal Link Dist (m)		507.8			328.1		418.0			489.9	
Turn Bay Length (m)	170.0		100.0	150.0		120.0		50.0	80.0		170.0
Base Capacity (vph)	510	2647	1001	219	1614	295	563	482	248	568	749
Starvation Cap Reductn	0	0	0	0	0	0	0	0	0	0	0
Spillback Cap Reductn	0	0	0	0	0	0	0	0	0	0	0
Storage Cap Reductn	0	0	0	0	0	0	0	0	0	0	0
Reduced v/c Ratio	1.00	0.53	0.25	0.39	1.00	0.79	0.42	0.14	0.32	0.35	0.83

Intersection Summary

~ Volume exceeds capacity, queue is theoretically infinite.  
Queue shown is maximum after two cycles.

# 95th percentile volume exceeds capacity, queue may be longer.  
Queue shown is maximum after two cycles.

## Queues

2027 Future Total Conditions

## 104: Mayfield Rd &amp; 12035 Dixie Rd Development Access

PM Peak Hour



Lane Group	EBL	EBT	WBT	SBT
Lane Group Flow (vph)	43	1499	1604	131
v/c Ratio	0.24	0.42	0.62	0.59
Control Delay	13.2	8.8	8.1	46.2
Queue Delay	0.0	0.0	0.0	0.0
Total Delay	13.2	8.8	8.1	46.2
Queue Length 50th (m)	3.3	43.0	69.2	19.8
Queue Length 95th (m)	m7.6	66.5	106.5	36.4
Internal Link Dist (m)		328.1	608.7	157.9
Turn Bay Length (m)	50.0			
Base Capacity (vph)	179	3577	2606	620
Starvation Cap Reductn	0	0	0	0
Spillback Cap Reductn	0	0	0	0
Storage Cap Reductn	0	0	0	0
Reduced v/c Ratio	0.24	0.42	0.62	0.21

## Intersection Summary

m Volume for 95th percentile queue is metered by upstream signal.

## **Appendix F**

### **WB-20 Tractor-Semitrailer Truck Movements at the Site Access**

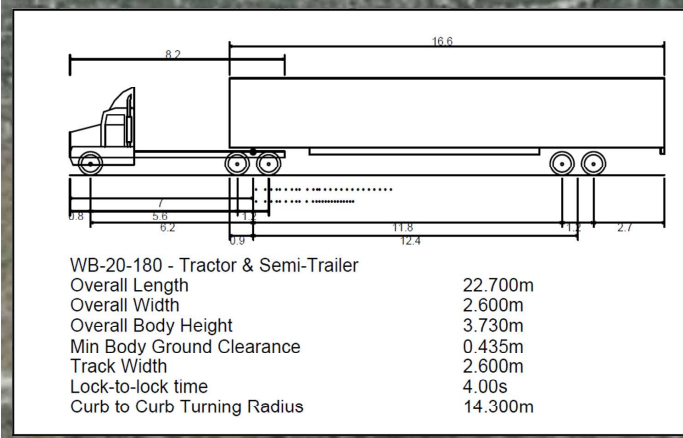

WB-20-180 - Tractor & Semi-Trailer  
 Overall Length 22.700m  
 Overall Width 2.600m  
 Overall Body Height 3.730m  
 Min Body Ground Clearance 0.435m  
 Track Width 2.600m  
 Lock-to-lock time 4.00s  
 Curb to Curb Turning Radius 14.300m

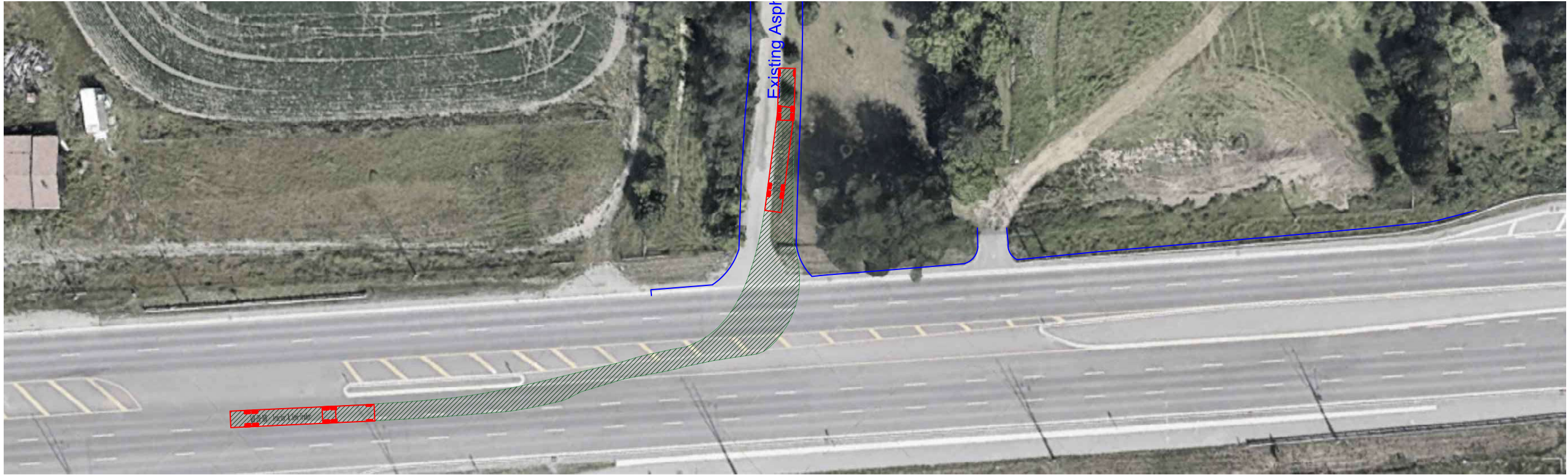
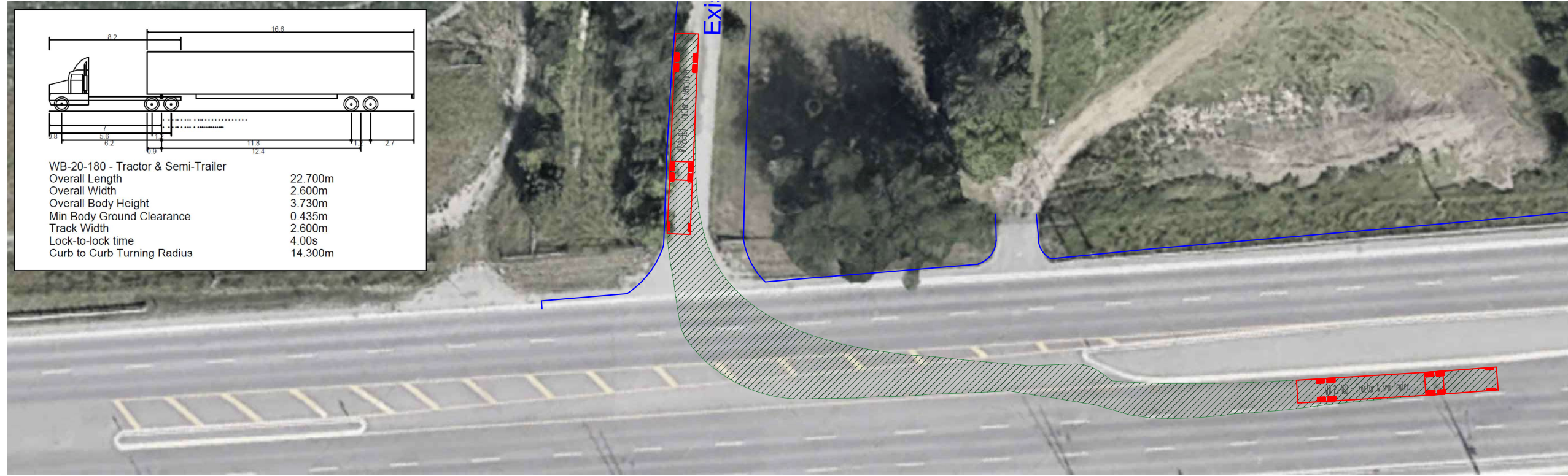

REV.	SUBMISSION	DATE	INITIAL

**4848 Mayfield Road  
Traffic Impact Study**





























DESIGN	DRAWN	CHECKED	CONTRACT No.
SCALE:	DRAWING NUMBER		WB-20 Tractor & Semi-Trailer
DATE:			

## **Appendix G**

### **Future (2032) Total Intersection Operation Calculations (Synchro)**

HCM Signalized Intersection Capacity Analysis  
101: Bramalea Rd & Mayfield Rd

2032 Future Total Conditions  
AM Peak Hour

													
Movement	EBL	EBT	EBR	WBL	WBT	WBR	NBL	NBT	NBR	SBL	SBT	SBR	
Lane Configurations		  			  						 		
Traffic Volume (vph)	345	1272	266	133	895	30	80	175	72	58	251	195	
Future Volume (vph)	345	1272	266	133	895	30	80	175	72	58	251	195	
Ideal Flow (vphpl)	1900	1900	1900	1900	1900	1900	1900	1900	1900	1900	1900	1900	
Lane Width	3.5	3.7	3.5	3.5	3.7	3.5	3.5	3.7	3.5	3.5	3.7	3.5	
Total Lost time (s)	3.0	7.2	7.2	7.2	7.2	7.2	7.1	7.1	7.1	3.0	7.1		
Lane Util. Factor	1.00	0.91	1.00	1.00	0.91	1.00	1.00	1.00	1.00	1.00	0.95		
Frbp, ped/bikes	1.00	1.00	0.99	1.00	1.00	1.00	1.00	1.00	0.98	1.00	1.00		
Flpb, ped/bikes	1.00	1.00	1.00	1.00	1.00	1.00	1.00	1.00	1.00	1.00	1.00		
Frt	1.00	1.00	0.85	1.00	1.00	0.85	1.00	1.00	0.85	1.00	0.93		
Flt Protected	0.95	1.00	1.00	0.95	1.00	1.00	0.95	1.00	1.00	0.95	1.00		
Satd. Flow (prot)	1785	4683	1515	1608	4445	1157	1700	1847	1427	1591	3362		
Flt Permitted	0.27	1.00	1.00	0.21	1.00	1.00	0.49	1.00	1.00	0.48	1.00		
Satd. Flow (perm)	503	4683	1515	349	4445	1157	884	1847	1427	811	3362		
Peak-hour factor, PHF	1.00	1.00	1.00	1.00	1.00	1.00	1.00	1.00	1.00	1.00	1.00	1.00	
Adj. Flow (vph)	345	1272	266	133	895	30	80	175	72	58	251	195	
RTOR Reduction (vph)	0	0	104	0	0	15	0	0	60	0	127	0	
Lane Group Flow (vph)	345	1272	162	133	895	15	80	175	12	58	319	0	
Confl. Peds. (#/hr)			2	2					9	9			
Heavy Vehicles (%)	0%	12%	4%	11%	18%	38%	5%	4%	10%	12%	1%	2%	
Turn Type	pm+pt	NA	Perm	Perm	NA	Perm	Perm	NA	Perm	pm+pt	NA		
Protected Phases	5	2			6			4		3	8		
Permitted Phases	2		2	6		6	4		4	8			
Actuated Green, G (s)	62.4	62.4	62.4	52.4	52.4	52.4	17.2	17.2	17.2	25.6	25.6		
Effective Green, g (s)	62.4	62.4	62.4	52.4	52.4	52.4	17.2	17.2	17.2	25.6	25.6		
Actuated g/C Ratio	0.61	0.61	0.61	0.51	0.51	0.51	0.17	0.17	0.17	0.25	0.25		
Clearance Time (s)	3.0	7.2	7.2	7.2	7.2	7.2	7.1	7.1	7.1	3.0	7.1		
Vehicle Extension (s)	5.0	5.0	5.0	5.0	5.0	5.0	5.0	5.0	5.0	5.0	5.0		
Lane Grp Cap (vph)	394	2856	924	178	2276	592	148	310	239	244	841		
v/s Ratio Prot	c0.06	0.27			0.20			c0.09		0.01	c0.09		
v/s Ratio Perm	c0.47		0.11	0.38		0.01	0.09		0.01	0.05			
v/c Ratio	0.88	0.45	0.18	0.75	0.39	0.03	0.54	0.56	0.05	0.24	0.38		
Uniform Delay, d1	12.7	10.7	8.7	19.7	15.2	12.3	38.9	39.1	35.7	30.0	31.8		
Progression Factor	1.00	1.00	1.00	1.00	1.00	1.00	1.00	1.00	1.00	1.00	1.00		
Incremental Delay, d2	20.4	0.5	0.4	24.6	0.5	0.1	6.9	3.8	0.2	1.1	0.6		
Delay (s)	33.1	11.2	9.1	44.3	15.8	12.4	45.9	42.9	35.9	31.0	32.4		
Level of Service	C	B	A	D	B	B	D	D	D	C	C		
Approach Delay (s)		14.9			19.2			42.1			32.2		
Approach LOS		B			B			D			C		
<b>Intersection Summary</b>													
HCM 2000 Control Delay			20.8		HCM 2000 Level of Service						C		
HCM 2000 Volume to Capacity ratio			0.81										
Actuated Cycle Length (s)			102.3		Sum of lost time (s)						20.3		
Intersection Capacity Utilization			97.0%		ICU Level of Service						F		
Analysis Period (min)			15										
c	Critical Lane Group												

HCM Signalized Intersection Capacity Analysis  
 102: Dixie Rd & Mayfield Rd





























2032 Future Total Conditions  
 AM Peak Hour

Movement	EBL	EBT	EBR	WBL	WBT	WBR	NBL	NBT	NBR	SBL	SBT	SBR
Lane Configurations												
Traffic Volume (vph)	589	1850	341	57	1128	97	206	177	81	52	211	518
Future Volume (vph)	589	1850	341	57	1128	97	206	177	81	52	211	518
Ideal Flow (vphpl)	1900	1900	1900	1900	1900	1900	1900	1900	1900	1900	1900	1900
Lane Width	3.5	3.7	3.5	3.5	3.7	3.5	3.5	3.7	3.5	3.5	3.7	3.5
Total Lost time (s)	3.0	6.9	6.9	3.0	6.9		6.9	6.9	6.9	6.9	6.9	6.9
Lane Util. Factor	1.00	0.91	1.00	1.00	0.91		1.00	1.00	1.00	1.00	1.00	1.00
Frpb, ped/bikes	1.00	1.00	0.98	1.00	1.00		1.00	1.00	1.00	1.00	1.00	0.99
Flpb, ped/bikes	1.00	1.00	1.00	1.00	1.00		1.00	1.00	1.00	1.00	1.00	1.00
Frt	1.00	1.00	0.85	1.00	0.99		1.00	1.00	0.85	1.00	1.00	0.85
Flt Protected	0.95	1.00	1.00	0.95	1.00		0.95	1.00	1.00	0.95	1.00	1.00
Satd. Flow (prot)	1623	4768	1533	1566	4413		1698	1830	1389	1552	1779	1472
Flt Permitted	0.12	1.00	1.00	0.09	1.00		0.56	1.00	1.00	0.61	1.00	1.00
Satd. Flow (perm)	209	4768	1533	146	4413		997	1830	1389	995	1779	1472
Peak-hour factor, PHF	1.00	1.00	1.00	1.00	1.00	1.00	1.00	1.00	1.00	1.00	1.00	1.00
Adj. Flow (vph)	589	1850	341	57	1128	97	206	177	81	52	211	518
RTOR Reduction (vph)	0	0	172	0	8	0	0	0	56	0	0	136
Lane Group Flow (vph)	589	1850	169	57	1217	0	206	177	25	52	211	382
Confl. Peds. (#/hr)							2					2
Confl. Bikes (#/hr)			1									
Heavy Vehicles (%)	10%	10%	2%	14%	18%	11%	5%	5%	15%	15%	8%	7%
Turn Type	pm+pt	NA	Perm	pm+pt	NA		Perm	NA	Perm	Perm	NA	Perm
Protected Phases	5	2		1	6			4			8	
Permitted Phases	2		2	6			4		4	8		8
Actuated Green, G (s)	68.8	59.3	59.3	51.6	45.1		37.4	37.4	37.4	37.4	37.4	37.4
Effective Green, g (s)	68.8	59.3	59.3	51.6	45.1		37.4	37.4	37.4	37.4	37.4	37.4
Actuated g/C Ratio	0.57	0.49	0.49	0.43	0.38		0.31	0.31	0.31	0.31	0.31	0.31
Clearance Time (s)	3.0	6.9	6.9	3.0	6.9		6.9	6.9	6.9	6.9	6.9	6.9
Vehicle Extension (s)	5.0	5.0	5.0	5.0	5.0		5.0	5.0	5.0	5.0	5.0	5.0
Lane Grp Cap (vph)	363	2356	757	139	1658		310	570	432	310	554	458
v/s Ratio Prot	c0.28	0.39		0.02	0.28			0.10			0.12	
v/s Ratio Perm	c0.65		0.11	0.15			0.21		0.02	0.05		c0.26
v/c Ratio	1.62	0.79	0.22	0.41	0.73		0.66	0.31	0.06	0.17	0.38	0.83
Uniform Delay, d1	32.3	25.1	17.2	21.6	32.3		35.9	31.5	29.0	30.0	32.3	38.4
Progression Factor	1.00	1.00	1.00	1.29	1.14		1.00	1.00	1.00	1.00	1.00	1.00
Incremental Delay, d2	292.5	2.7	0.7	3.7	2.7		6.9	0.7	0.1	0.5	0.9	13.7
Delay (s)	324.8	27.8	17.9	31.5	39.5		42.8	32.1	29.1	30.5	33.2	52.1
Level of Service	F	C	B	C	D		D	C	C	C	C	D
Approach Delay (s)		89.5			39.2			36.3			45.6	
Approach LOS		F			D			D			D	
<b>Intersection Summary</b>												
HCM 2000 Control Delay			66.2			HCM 2000 Level of Service			E			
HCM 2000 Volume to Capacity ratio			1.37									
Actuated Cycle Length (s)			120.0			Sum of lost time (s)			16.8			
Intersection Capacity Utilization			101.4%			ICU Level of Service			G			
Analysis Period (min)			15									

c Critical Lane Group

HCM Signalized Intersection Capacity Analysis  
102: Dixie Rd & Mayfield Rd

























2032 Future Total Conditions (Mitigation)  
AM Peak Hour

												
Movement	EBL	EBT	EBR	WBL	WBT	WBR	NBL	NBT	NBR	SBL	SBT	SBR
Lane Configurations	 	  			  						 	
Traffic Volume (vph)	589	1850	341	57	1128	97	206	177	81	52	211	518
Future Volume (vph)	589	1850	341	57	1128	97	206	177	81	52	211	518
Ideal Flow (vphpl)	1900	1900	1900	1900	1900	1900	1900	1900	1900	1900	1900	1900
Lane Width	3.5	3.7	3.5	3.5	3.7	3.5	3.5	3.7	3.5	3.5	3.7	3.5
Total Lost time (s)	5.3	6.9	6.9	3.0	6.9		6.9	6.9	6.9	6.9	6.9	6.9
Lane Util. Factor	0.97	0.91	1.00	1.00	0.91		1.00	1.00	1.00	1.00	1.00	1.00
Frbp, ped/bikes	1.00	1.00	0.98	1.00	1.00		1.00	1.00	1.00	1.00	1.00	0.99
Flpb, ped/bikes	1.00	1.00	1.00	1.00	1.00		1.00	1.00	1.00	1.00	1.00	1.00
Frt	1.00	1.00	0.85	1.00	0.99		1.00	1.00	0.85	1.00	1.00	0.85
Flt Protected	0.95	1.00	1.00	0.95	1.00		0.95	1.00	1.00	0.95	1.00	1.00
Satd. Flow (prot)	3148	4768	1533	1566	4413		1698	1830	1389	1552	1779	1472
Flt Permitted	0.13	1.00	1.00	0.10	1.00		0.50	1.00	1.00	0.56	1.00	1.00
Satd. Flow (perm)	434	4768	1533	169	4413		887	1830	1389	909	1779	1472
Peak-hour factor, PHF	1.00	1.00	1.00	1.00	1.00	1.00	1.00	1.00	1.00	1.00	1.00	1.00
Adj. Flow (vph)	589	1850	341	57	1128	97	206	177	81	52	211	518
RTOR Reduction (vph)	0	0	140	0	5	0	0	0	60	0	0	382
Lane Group Flow (vph)	589	1850	201	57	1220	0	206	177	21	52	211	136
Confl. Peds. (#/hr)							2					2
Confl. Bikes (#/hr)			1									
Heavy Vehicles (%)	10%	10%	2%	14%	18%	11%	5%	5%	15%	15%	8%	7%
Turn Type	pm+pt	NA	Perm	pm+pt	NA		Perm	NA	Perm	Perm	NA	Perm
Protected Phases	5	2		1	6			4			8	
Permitted Phases	2		2	6			4		4	8		8
Actuated Green, G (s)	97.9	88.5	88.5	69.7	63.3		38.3	38.3	38.3	38.3	38.3	38.3
Effective Green, g (s)	97.9	88.5	88.5	69.7	63.3		38.3	38.3	38.3	38.3	38.3	38.3
Actuated g/C Ratio	0.65	0.59	0.59	0.46	0.42		0.26	0.26	0.26	0.26	0.26	0.26
Clearance Time (s)	5.3	6.9	6.9	3.0	6.9		6.9	6.9	6.9	6.9	6.9	6.9
Vehicle Extension (s)	5.0	5.0	5.0	5.0	5.0		5.0	5.0	5.0	5.0	5.0	5.0
Lane Grp Cap (vph)	813	2813	904	138	1862		226	467	354	232	454	375
v/s Ratio Prot	c0.14	0.39		0.02	0.28			0.10			0.12	
v/s Ratio Perm	c0.33		0.13	0.17			c0.23		0.01	0.06		0.09
v/c Ratio	0.72	0.66	0.22	0.41	0.66		0.91	0.38	0.06	0.22	0.46	0.36
Uniform Delay, d1	27.8	20.6	14.5	22.4	34.6		54.2	46.0	42.2	44.1	47.2	45.8
Progression Factor	1.00	1.00	1.00	1.00	1.00		1.00	1.00	1.00	1.00	1.00	1.00
Incremental Delay, d2	3.9	1.2	0.6	4.2	1.8		38.1	1.1	0.1	1.0	1.6	1.3
Delay (s)	31.8	21.8	15.1	26.6	36.4		92.3	47.1	42.4	45.1	48.8	47.1
Level of Service	C	C	B	C	D		F	D	D	D	D	D
Approach Delay (s)		23.1			36.0			66.4			47.4	
Approach LOS		C			D			E			D	
<b>Intersection Summary</b>												
HCM 2000 Control Delay			33.6			HCM 2000 Level of Service			C			
HCM 2000 Volume to Capacity ratio			0.79									
Actuated Cycle Length (s)			150.0			Sum of lost time (s)			19.1			
Intersection Capacity Utilization			86.6%			ICU Level of Service			E			
Analysis Period (min)			15									

c Critical Lane Group

HCM Signalized Intersection Capacity Analysis  
 104: Mayfield Rd & 12035 Dixie Rd Development Access

2032 Future Total Conditions  
 AM Peak Hour

												
Movement	EBL	EBT	EBR	WBL	WBT	WBR	NBL	NBT	NBR	SBL	SBT	SBR
Lane Configurations		  			 				 		 	
Traffic Volume (vph)	98	1884	0	0	1247	26	0	0	0	3	0	35
Future Volume (vph)	98	1884	0	0	1247	26	0	0	0	3	0	35
Ideal Flow (vphpl)	1900	1900	1900	1900	1900	1900	1900	1900	1900	1900	1900	1900
Lane Width	3.5	3.7	3.5	3.5	3.7	3.5	3.5	3.7	3.5	3.5	3.7	3.5
Total Lost time (s)	6.9	6.9			6.9							6.9
Lane Util. Factor	1.00	0.91			0.95							1.00
Frt	1.00	1.00			1.00							0.88
Flt Protected	0.95	1.00			1.00							1.00
Satd. Flow (prot)	1785	4768			3119							1676
Flt Permitted	0.21	1.00			1.00							0.97
Satd. Flow (perm)	391	4768			3119							1634
Peak-hour factor, PHF	1.00	1.00	1.00	1.00	1.00	1.00	1.00	1.00	1.00	1.00	1.00	1.00
Adj. Flow (vph)	98	1884	0	0	1247	26	0	0	0	3	0	35
RTOR Reduction (vph)	0	0	0	0	0	0	0	0	0	0	33	0
Lane Group Flow (vph)	98	1884	0	0	1273	0	0	0	0	0	5	0
Heavy Vehicles (%)	0%	10%	0%	0%	17%	0%	0%	0%	0%	0%	0%	0%
Turn Type	Perm	NA	Perm	Perm	NA					Perm	NA	
Protected Phases		2			6			8			4	
Permitted Phases	2		2	6			8			4		
Actuated Green, G (s)	100.7	100.7			100.7							5.5
Effective Green, g (s)	100.7	100.7			100.7							5.5
Actuated g/C Ratio	0.84	0.84			0.84							0.05
Clearance Time (s)	6.9	6.9			6.9							6.9
Vehicle Extension (s)	5.0	5.0			5.0							5.0
Lane Grp Cap (vph)	328	4001			2617							74
v/s Ratio Prot		0.40			c0.41							
v/s Ratio Perm	0.25											c0.00
v/c Ratio	0.30	0.47			0.49							0.06
Uniform Delay, d1	2.1	2.6			2.6							54.8
Progression Factor	4.46	4.80			1.00							1.00
Incremental Delay, d2	1.5	0.3			0.6							0.7
Delay (s)	10.8	12.6			3.3							55.5
Level of Service	B	B			A							E
Approach Delay (s)		12.5			3.3			0.0				55.5
Approach LOS		B			A			A				E
<b>Intersection Summary</b>												
HCM 2000 Control Delay			9.4		HCM 2000 Level of Service					A		
HCM 2000 Volume to Capacity ratio			0.46									
Actuated Cycle Length (s)			120.0		Sum of lost time (s)				13.8			
Intersection Capacity Utilization			70.3%		ICU Level of Service					C		
Analysis Period (min)			15									

c Critical Lane Group

HCM Unsignalized Intersection Capacity Analysis  
 103: Mayfield Rd & Site Access

2032 Future Total Conditions  
 AM Peak Hour

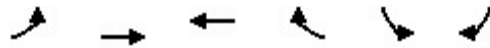

Movement	EBL	EBT	WBT	WBR	SBL	SBR
Lane Configurations		↑↑↑	↑↑		↑↑	
Traffic Volume (veh/h)	0	1887	1265	0	7	8
Future Volume (Veh/h)	0	1887	1265	0	7	8
Sign Control		Free	Free		Stop	
Grade		0%	0%		0%	
Peak Hour Factor	1.00	1.00	1.00	1.00	1.00	1.00
Hourly flow rate (vph)	0	1887	1265	0	7	8
<b>Pedestrians</b>						
Lane Width (m)						
Walking Speed (m/s)						
Percent Blockage						
Right turn flare (veh)						
Median type		None	None			
Median storage (veh)						
Upstream signal (m)	387					
pX, platoon unblocked	0.85				0.85	0.85
vC, conflicting volume	1265				1894	632
vC1, stage 1 conf vol						
vC2, stage 2 conf vol						
vCu, unblocked vol	969				1706	229
tC, single (s)	4.1				8.8	8.9
tC, 2 stage (s)						
tF (s)	2.2				4.5	4.3
p0 queue free %	100				73	98
cM capacity (veh/h)	614				26	464
Direction, Lane #	EB 1	EB 2	EB 3	WB 1	WB 2	SB 1
Volume Total	377	755	755	843	422	15
Volume Left	0	0	0	0	0	7
Volume Right	0	0	0	0	0	8
cSH	614	1700	1700	1700	1700	52
Volume to Capacity	0.00	0.44	0.44	0.50	0.25	0.29
Queue Length 95th (m)	0.0	0.0	0.0	0.0	0.0	7.1
Control Delay (s)	0.0	0.0	0.0	0.0	0.0	101.3
Lane LOS						F
Approach Delay (s)	0.0				0.0	101.3
Approach LOS						F
<b>Intersection Summary</b>						
Average Delay			0.5			
Intersection Capacity Utilization			46.5%	ICU Level of Service	A	
Analysis Period (min)			15			

HCM Unsignalized Intersection Capacity Analysis  
 103: Mayfield Rd & Site Access

























2032 Future Total Conditions (Mitigation)  
 AM Peak Hour



Movement	EBL	EBT	WBT	WBR	SBL	SBR
Lane Configurations		↑↑↑	↑↑		↑↑	
Traffic Volume (veh/h)	0	1887	1265	0	7	8
Future Volume (Veh/h)	0	1887	1265	0	7	8
Sign Control		Free	Free		Stop	
Grade		0%	0%		0%	
Peak Hour Factor	1.00	1.00	1.00	1.00	1.00	1.00
Hourly flow rate (vph)	0	1887	1265	0	7	8
<b>Pedestrians</b>						
Lane Width (m)						
Walking Speed (m/s)						
Percent Blockage						
Right turn flare (veh)						
Median type	TWLTL		TWLTL			
Median storage veh	2		2			
Upstream signal (m)	387					
pX, platoon unblocked	0.85				0.85	0.85
vC, conflicting volume	1265				1894	632
vC1, stage 1 conf vol					1265	
vC2, stage 2 conf vol					629	
vCu, unblocked vol	969				1706	229
tC, single (s)	4.1				8.8	8.9
tC, 2 stage (s)					7.8	
tF (s)	2.2				4.5	4.3
p0 queue free %	100				94	98
cM capacity (veh/h)	614				127	464
Direction, Lane #	EB 1	EB 2	EB 3	WB 1	WB 2	SB 1
Volume Total	377	755	755	843	422	15
Volume Left	0	0	0	0	0	7
Volume Right	0	0	0	0	0	8
cSH	614	1700	1700	1700	1700	208
Volume to Capacity	0.00	0.44	0.44	0.50	0.25	0.07
Queue Length 95th (m)	0.0	0.0	0.0	0.0	0.0	1.6
Control Delay (s)	0.0	0.0	0.0	0.0	0.0	23.7
Lane LOS						C
Approach Delay (s)	0.0				0.0	23.7
Approach LOS						C
<b>Intersection Summary</b>						
Average Delay			0.1			
Intersection Capacity Utilization			46.5%	ICU Level of Service		A
Analysis Period (min)			15			

HCM Signalized Intersection Capacity Analysis  
101: Bramalea Rd & Mayfield Rd

2032 Future Total Conditions  
PM Peak Hour

												
Movement	EBL	EBT	EBR	WBL	WBT	WBR	NBL	NBT	NBR	SBL	SBT	SBR
Lane Configurations												
Traffic Volume (vph)	171	1146	174	144	1236	30	317	209	72	32	127	111
Future Volume (vph)	171	1146	174	144	1236	30	317	209	72	32	127	111
Ideal Flow (vphpl)	1900	1900	1900	1900	1900	1900	1900	1900	1900	1900	1900	1900
Lane Width	3.5	3.7	3.5	3.5	3.7	3.5	3.5	3.7	3.5	3.5	3.7	3.5
Total Lost time (s)	3.0	7.2	7.2	7.2	7.2	7.2	7.1	7.1	7.1	3.0	7.1	
Lane Util. Factor	1.00	0.91	1.00	1.00	0.91	1.00	1.00	1.00	1.00	1.00	0.95	
Frbp, ped/bikes	1.00	1.00	0.99	1.00	1.00	0.97	1.00	1.00	0.99	1.00	0.99	
Flpb, ped/bikes	1.00	1.00	1.00	1.00	1.00	1.00	1.00	1.00	1.00	1.00	1.00	
Frt	1.00	1.00	0.85	1.00	1.00	0.85	1.00	1.00	0.85	1.00	0.93	
Flt Protected	0.95	1.00	1.00	0.95	1.00	1.00	0.95	1.00	1.00	0.95	1.00	
Satd. Flow (prot)	1767	4683	1545	1784	4856	1480	1766	1921	1577	1785	3281	
Flt Permitted	0.14	1.00	1.00	0.23	1.00	1.00	0.60	1.00	1.00	0.53	1.00	
Satd. Flow (perm)	257	4683	1545	431	4856	1480	1123	1921	1577	990	3281	
Peak-hour factor, PHF	1.00	1.00	1.00	1.00	1.00	1.00	1.00	1.00	1.00	1.00	1.00	1.00
Adj. Flow (vph)	171	1146	174	144	1236	30	317	209	72	32	127	111
RTOR Reduction (vph)	0	0	86	0	0	17	0	0	49	0	69	0
Lane Group Flow (vph)	171	1146	88	144	1236	13	317	209	23	32	169	0
Confl. Peds. (#/hr)	6		2	2		6	1					1
Confl. Bikes (#/hr)									1			
Heavy Vehicles (%)	1%	12%	2%	0%	8%	5%	1%	0%	0%	0%	1%	5%
Turn Type	pm+pt	NA	Perm	Perm	NA	Perm	Perm	NA	Perm	pm+pt	NA	
Protected Phases	5	2			6			4		3	8	
Permitted Phases	2		2	6		6	4		4	8		
Actuated Green, G (s)	63.0	63.0	63.0	52.9	52.9	52.9	40.4	40.4	40.4	47.2	47.2	
Effective Green, g (s)	63.0	63.0	63.0	52.9	52.9	52.9	40.4	40.4	40.4	47.2	47.2	
Actuated g/C Ratio	0.51	0.51	0.51	0.42	0.42	0.42	0.32	0.32	0.32	0.38	0.38	
Clearance Time (s)	3.0	7.2	7.2	7.2	7.2	7.2	7.1	7.1	7.1	3.0	7.1	
Vehicle Extension (s)	5.0	5.0	5.0	5.0	5.0	5.0	5.0	5.0	5.0	5.0	5.0	
Lane Grp Cap (vph)	216	2369	781	183	2063	628	364	623	511	399	1243	
v/s Ratio Prot	c0.05	0.24			0.25			0.11		0.00	c0.05	
v/s Ratio Perm	c0.36		0.06	0.33		0.01	c0.28		0.01	0.03		
v/c Ratio	0.79	0.48	0.11	0.79	0.60	0.02	0.87	0.34	0.05	0.08	0.14	
Uniform Delay, d1	19.6	20.1	16.1	30.9	27.6	20.8	39.6	31.9	28.8	24.6	25.3	
Progression Factor	1.00	1.00	1.00	1.00	1.00	1.00	1.00	1.00	1.00	1.00	1.00	
Incremental Delay, d2	20.1	0.7	0.3	28.1	1.3	0.1	21.1	0.7	0.1	0.2	0.1	
Delay (s)	39.7	20.8	16.4	59.0	28.9	20.8	60.7	32.5	28.9	24.8	25.4	
Level of Service	D	C	B	E	C	C	E	C	C	C	C	
Approach Delay (s)		22.5			31.8			47.0			25.3	
Approach LOS		C			C			D			C	
<b>Intersection Summary</b>												
HCM 2000 Control Delay			30.1		HCM 2000 Level of Service					C		
HCM 2000 Volume to Capacity ratio			0.82									
Actuated Cycle Length (s)			124.5		Sum of lost time (s)					20.3		
Intersection Capacity Utilization			103.0%		ICU Level of Service					G		
Analysis Period (min)			15									

c Critical Lane Group

HCM Signalized Intersection Capacity Analysis  
102: Dixie Rd & Mayfield Rd





























2032 Future Total Conditions  
PM Peak Hour

Movement	EBL	EBT	EBR	WBL	WBT	WBR	NBL	NBT	NBR	SBL	SBT	SBR
Lane Configurations												
Traffic Volume (vph)	575	1650	295	97	1831	77	275	276	78	88	219	699
Future Volume (vph)	575	1650	295	97	1831	77	275	276	78	88	219	699
Ideal Flow (vphpl)	1900	1900	1900	1900	1900	1900	1900	1900	1900	1900	1900	1900
Lane Width	3.5	3.7	3.5	3.5	3.7	3.5	3.5	3.7	3.5	3.5	3.7	3.5
Total Lost time (s)	3.0	6.9	6.9	3.0	6.9		6.9	6.9	6.9	6.9	6.9	6.9
Lane Util. Factor	1.00	0.91	1.00	1.00	0.91		1.00	1.00	1.00	1.00	1.00	1.00
Frpb, ped/bikes	1.00	1.00	1.00	1.00	1.00		1.00	1.00	0.99	1.00	1.00	0.98
Flpb, ped/bikes	1.00	1.00	1.00	1.00	1.00		1.00	1.00	1.00	1.00	1.00	1.00
Frt	1.00	1.00	0.85	1.00	0.99		1.00	1.00	0.85	1.00	1.00	0.85
Flt Protected	0.95	1.00	1.00	0.95	1.00		0.95	1.00	1.00	0.95	1.00	1.00
Satd. Flow (prot)	1580	4683	1581	1684	4846		1763	1865	1432	1698	1883	1440
Flt Permitted	0.09	1.00	1.00	0.10	1.00		0.57	1.00	1.00	0.50	1.00	1.00
Satd. Flow (perm)	154	4683	1581	177	4846		1065	1865	1432	899	1883	1440
Peak-hour factor, PHF	1.00	1.00	1.00	1.00	1.00	1.00	1.00	1.00	1.00	1.00	1.00	1.00
Adj. Flow (vph)	575	1650	295	97	1831	77	275	276	78	88	219	699
RTOR Reduction (vph)	0	0	170	0	4	0	0	0	49	0	0	176
Lane Group Flow (vph)	575	1650	125	97	1904	0	275	276	29	88	219	523
Confl. Peds. (#/hr)	5					5	4		2	2		4
Confl. Bikes (#/hr)												3
Heavy Vehicles (%)	13%	12%	1%	6%	7%	18%	1%	3%	10%	5%	2%	9%
Turn Type	pm+pt	NA	Perm	pm+pt	NA		Perm	NA	Perm	Perm	NA	Perm
Protected Phases	5	2		1	6			4			8	
Permitted Phases	2		2	6			4		4	8		8
Actuated Green, G (s)	61.0	50.7	50.7	47.4	40.1		45.2	45.2	45.2	45.2	45.2	45.2
Effective Green, g (s)	61.0	50.7	50.7	47.4	40.1		45.2	45.2	45.2	45.2	45.2	45.2
Actuated g/C Ratio	0.51	0.42	0.42	0.39	0.33		0.38	0.38	0.38	0.38	0.38	0.38
Clearance Time (s)	3.0	6.9	6.9	3.0	6.9		6.9	6.9	6.9	6.9	6.9	6.9
Vehicle Extension (s)	5.0	5.0	5.0	5.0	5.0		5.0	5.0	5.0	5.0	5.0	5.0
Lane Grp Cap (vph)	290	1978	667	161	1619		401	702	539	338	709	542
v/s Ratio Prot	c0.29	0.35		0.04	0.39			0.15			0.12	
v/s Ratio Perm	c0.71		0.08	0.20			0.26		0.02	0.10		c0.36
v/c Ratio	1.98	0.83	0.19	0.60	1.18		0.69	0.39	0.05	0.26	0.31	0.96
Uniform Delay, d1	37.6	30.9	21.7	25.2	40.0		31.4	27.4	23.8	25.8	26.4	36.6
Progression Factor	1.00	1.00	1.00	0.93	0.84		1.00	1.00	1.00	1.00	1.00	1.00
Incremental Delay, d2	454.4	4.3	0.6	6.4	84.1		6.2	0.8	0.1	0.9	0.5	30.0
Delay (s)	492.1	35.2	22.3	29.8	117.8		37.6	28.1	23.9	26.7	26.9	66.6
Level of Service	F	D	C	C	F		D	C	C	C	C	E
Approach Delay (s)		138.0			113.5			31.7			54.5	
Approach LOS		F			F			C			D	
<b>Intersection Summary</b>												
HCM 2000 Control Delay			105.5			HCM 2000 Level of Service			F			
HCM 2000 Volume to Capacity ratio			1.58									
Actuated Cycle Length (s)			120.0			Sum of lost time (s)			16.8			
Intersection Capacity Utilization			119.6%			ICU Level of Service			H			
Analysis Period (min)			15									

c Critical Lane Group

HCM Signalized Intersection Capacity Analysis  
102: Dixie Rd & Mayfield Rd

























2032 Future Total Conditions (Mitigation)  
PM Peak Hour

												
Movement	EBL	EBT	EBR	WBL	WBT	WBR	NBL	NBT	NBR	SBL	SBT	SBR
Lane Configurations	 	  			  						 	
Traffic Volume (vph)	575	1650	295	97	1831	77	275	276	78	88	219	699
Future Volume (vph)	575	1650	295	97	1831	77	275	276	78	88	219	699
Ideal Flow (vphpl)	1900	1900	1900	1900	1900	1900	1900	1900	1900	1900	1900	1900
Lane Width	3.5	3.7	3.5	3.5	3.7	3.5	3.5	3.7	3.5	3.5	3.7	3.5
Total Lost time (s)	3.0	6.9	6.9	3.0	6.9		6.9	6.9	6.9	6.9	6.9	3.0
Lane Util. Factor	0.97	0.91	1.00	1.00	0.91		1.00	1.00	1.00	1.00	1.00	1.00
Frbp, ped/bikes	1.00	1.00	1.00	1.00	1.00		1.00	1.00	0.99	1.00	1.00	0.99
Flpb, ped/bikes	1.00	1.00	1.00	1.00	1.00		1.00	1.00	1.00	1.00	1.00	1.00
Frt	1.00	1.00	0.85	1.00	0.99		1.00	1.00	0.85	1.00	1.00	0.85
Flt Protected	0.95	1.00	1.00	0.95	1.00		0.95	1.00	1.00	0.95	1.00	1.00
Satd. Flow (prot)	3064	4683	1581	1684	4848		1762	1865	1432	1698	1883	1449
Flt Permitted	0.06	1.00	1.00	0.11	1.00		0.52	1.00	1.00	0.43	1.00	1.00
Satd. Flow (perm)	200	4683	1581	193	4848		961	1865	1432	776	1883	1449
Peak-hour factor, PHF	1.00	1.00	1.00	1.00	1.00	1.00	1.00	1.00	1.00	1.00	1.00	1.00
Adj. Flow (vph)	575	1650	295	97	1831	77	275	276	78	88	219	699
RTOR Reduction (vph)	0	0	142	0	3	0	0	0	54	0	0	15
Lane Group Flow (vph)	575	1650	153	97	1905	0	275	276	24	88	219	684
Confl. Peds. (#/hr)	5					5	4		2	2		4
Confl. Bikes (#/hr)												3
Heavy Vehicles (%)	13%	12%	1%	6%	7%	18%	1%	3%	10%	5%	2%	9%
Turn Type	pm+pt	NA	Perm	pm+pt	NA		Perm	NA	Perm	Perm	NA	pm+ov
Protected Phases	5	2		1	6			4			8	5
Permitted Phases	2		2	6			4		4	8		8
Actuated Green, G (s)	90.7	78.0	78.0	71.3	61.6		45.5	45.5	45.5	45.5	45.5	71.6
Effective Green, g (s)	90.7	78.0	78.0	71.3	61.6		45.5	45.5	45.5	45.5	45.5	71.6
Actuated g/C Ratio	0.60	0.52	0.52	0.48	0.41		0.30	0.30	0.30	0.30	0.30	0.48
Clearance Time (s)	3.0	6.9	6.9	3.0	6.9		6.9	6.9	6.9	6.9	6.9	3.0
Vehicle Extension (s)	5.0	5.0	5.0	5.0	5.0		5.0	5.0	5.0	5.0	5.0	5.0
Lane Grp Cap (vph)	619	2435	822	188	1990		291	565	434	235	571	691
v/s Ratio Prot	0.16	0.35		0.03	0.39			0.15			0.12	c0.17
v/s Ratio Perm	c0.40		0.10	0.21			0.29		0.02	0.11		0.30
v/c Ratio	0.93	0.68	0.19	0.52	0.96		0.95	0.49	0.05	0.37	0.38	0.99
Uniform Delay, d1	49.3	26.7	19.1	22.9	42.9		51.0	42.7	37.0	41.1	41.2	38.9
Progression Factor	1.00	1.00	1.00	1.00	1.00		1.00	1.00	1.00	1.00	1.00	1.00
Incremental Delay, d2	21.1	1.5	0.5	4.7	12.3		38.9	1.4	0.1	2.1	0.9	31.8
Delay (s)	70.4	28.2	19.6	27.5	55.3		89.9	44.1	37.1	43.2	42.1	70.7
Level of Service	E	C	B	C	E		F	D	D	D	D	E
Approach Delay (s)		36.8			53.9			63.3			62.0	
Approach LOS		D			D			E			E	
<b>Intersection Summary</b>												
HCM 2000 Control Delay			49.2			HCM 2000 Level of Service			D			
HCM 2000 Volume to Capacity ratio			0.98									
Actuated Cycle Length (s)			150.0			Sum of lost time (s)			16.8			
Intersection Capacity Utilization			110.9%			ICU Level of Service			H			
Analysis Period (min)			15									

c Critical Lane Group

HCM Signalized Intersection Capacity Analysis  
 104: Mayfield Rd & 12035 Dixie Rd Development Access

2032 Future Total Conditions  
 PM Peak Hour

												
Movement	EBL	EBT	EBR	WBL	WBT	WBR	NBL	NBT	NBR	SBL	SBT	SBR
Lane Configurations		  			 			 			 	
Traffic Volume (vph)	43	1773	0	0	1900	3	0	0	0	27	0	104
Future Volume (vph)	43	1773	0	0	1900	3	0	0	0	27	0	104
Ideal Flow (vphpl)	1900	1900	1900	1900	1900	1900	1900	1900	1900	1900	1900	1900
Lane Width	3.5	3.7	3.5	3.5	3.7	3.5	3.5	3.7	3.5	3.5	3.7	3.5
Total Lost time (s)	6.9	6.9			6.9							6.9
Lane Util. Factor	1.00	0.91			0.95							1.00
Frt	1.00	1.00			1.00							0.89
Flt Protected	0.95	1.00			1.00							0.99
Satd. Flow (prot)	1785	4683			3411							1698
Flt Permitted	0.08	1.00			1.00							0.93
Satd. Flow (perm)	148	4683			3411							1592
Peak-hour factor, PHF	1.00	1.00	1.00	1.00	1.00	1.00	1.00	1.00	1.00	1.00	1.00	1.00
Adj. Flow (vph)	43	1773	0	0	1900	3	0	0	0	27	0	104
RTOR Reduction (vph)	0	0	0	0	0	0	0	0	0	0	31	0
Lane Group Flow (vph)	43	1773	0	0	1903	0	0	0	0	0	100	0
Heavy Vehicles (%)	0%	12%	0%	0%	7%	0%	0%	0%	0%	0%	0%	0%
Turn Type	Perm	NA	Perm	Perm	NA					Perm	NA	
Protected Phases		2			6			8			4	
Permitted Phases	2		2	6			8			4		
Actuated Green, G (s)	91.7	91.7			91.7							14.5
Effective Green, g (s)	91.7	91.7			91.7							14.5
Actuated g/C Ratio	0.76	0.76			0.76							0.12
Clearance Time (s)	6.9	6.9			6.9							6.9
Vehicle Extension (s)	5.0	5.0			5.0							5.0
Lane Grp Cap (vph)	113	3578			2606							192
v/s Ratio Prot		0.38			c0.56							
v/s Ratio Perm	0.29											c0.06
v/c Ratio	0.38	0.50			0.73							0.52
Uniform Delay, d1	4.7	5.4			7.6							49.5
Progression Factor	2.41	2.03			1.00							1.00
Incremental Delay, d2	5.8	0.3			1.8							4.8
Delay (s)	17.2	11.2			9.4							54.3
Level of Service	B	B			A							D
Approach Delay (s)		11.4			9.4			0.0				54.3
Approach LOS		B			A			A				D
<b>Intersection Summary</b>												
HCM 2000 Control Delay			11.8									B
HCM 2000 Volume to Capacity ratio			0.70									
Actuated Cycle Length (s)			120.0							13.8		
Intersection Capacity Utilization			72.0%									C
Analysis Period (min)			15									

c Critical Lane Group

HCM Unsignalized Intersection Capacity Analysis  
 103: Mayfield Rd & Site Access

2032 Future Total Conditions  
 PM Peak Hour



Movement	EBL	EBT	WBT	WBR	SBL	SBR
Lane Configurations		↑↑↑	↑↑		↘	
Traffic Volume (veh/h)	8	1792	1903	7	0	0
Future Volume (Veh/h)	8	1792	1903	7	0	0
Sign Control		Free	Free		Stop	
Grade		0%	0%		0%	
Peak Hour Factor	1.00	1.00	1.00	1.00	1.00	1.00
Hourly flow rate (vph)	8	1792	1903	7	0	0
<b>Pedestrians</b>						
Lane Width (m)						
Walking Speed (m/s)						
Percent Blockage						
Right turn flare (veh)						
Median type		None	None			
Median storage veh						
Upstream signal (m)	387					
pX, platoon unblocked	0.75				0.75	0.75
vC, conflicting volume	1910				2520	955
vC1, stage 1 conf vol						
vC2, stage 2 conf vol						
vCu, unblocked vol	1540				2357	260
tC, single (s)	6.1				6.8	6.9
tC, 2 stage (s)						
tF (s)	3.2				3.5	3.3
p0 queue free %	93				100	100
cM capacity (veh/h)	113				21	556
Direction, Lane #	EB 1	EB 2	EB 3	WB 1	WB 2	SB 1
Volume Total	366	717	717	1269	641	0
Volume Left	8	0	0	0	0	0
Volume Right	0	0	0	0	7	0
cSH	113	1700	1700	1700	1700	1700
Volume to Capacity	0.07	0.42	0.42	0.75	0.38	0.00
Queue Length 95th (m)	1.6	0.0	0.0	0.0	0.0	0.0
Control Delay (s)	4.3	0.0	0.0	0.0	0.0	0.0
Lane LOS	A					A
Approach Delay (s)	0.9			0.0		0.0
Approach LOS						A
<b>Intersection Summary</b>						
Average Delay	0.4					
Intersection Capacity Utilization	56.2%					
ICU Level of Service	B					
Analysis Period (min)	15					

Queues  
101: Bramalea Rd & Mayfield Rd

2032 Future Total Conditions  
AM Peak Hour



Lane Group	EBL	EBT	EBR	WBL	WBT	WBR	NBL	NBT	NBR	SBL	SBT
Lane Group Flow (vph)	345	1272	266	133	895	30	80	175	72	58	446
v/c Ratio	0.83	0.44	0.26	0.74	0.39	0.05	0.54	0.56	0.23	0.20	0.47
Control Delay	30.4	12.0	2.1	50.2	16.7	0.1	53.0	46.4	8.8	27.4	20.7
Queue Delay	0.0	0.0	0.0	0.0	0.0	0.0	0.0	0.0	0.0	0.0	0.0
Total Delay	30.4	12.0	2.1	50.2	16.7	0.1	53.0	46.4	8.8	27.4	20.7
Queue Length 50th (m)	25.7	43.5	0.0	18.8	35.9	0.0	13.7	30.2	0.0	7.8	21.7
Queue Length 95th (m)	#70.2	64.5	10.1	#56.6	52.7	0.0	27.8	49.2	8.9	16.1	34.4
Internal Link Dist (m)		182.8			347.4			479.0			343.8
Turn Bay Length (m)	180.0		110.0	80.0		100.0	100.0			110.0	
Base Capacity (vph)	418	2872	1031	179	2286	634	446	932	758	285	2095
Starvation Cap Reductn	0	0	0	0	0	0	0	0	0	0	0
Spillback Cap Reductn	0	0	0	0	0	0	0	0	0	0	0
Storage Cap Reductn	0	0	0	0	0	0	0	0	0	0	0
Reduced v/c Ratio	0.83	0.44	0.26	0.74	0.39	0.05	0.18	0.19	0.09	0.20	0.21

Intersection Summary

# 95th percentile volume exceeds capacity, queue may be longer.  
Queue shown is maximum after two cycles.

Queues  
102: Dixie Rd & Mayfield Rd

2032 Future Total Conditions  
AM Peak Hour



Lane Group	EBL	EBT	EBR	WBL	WBT	NBL	NBT	NBR	SBL	SBT	SBR
Lane Group Flow (vph)	589	1850	341	57	1225	206	177	81	52	211	518
v/c Ratio	1.60	0.78	0.36	0.35	0.74	0.66	0.31	0.16	0.17	0.38	0.87
Control Delay	306.0	30.0	3.5	22.4	39.5	45.1	31.2	4.9	28.0	32.6	39.0
Queue Delay	0.0	0.0	0.0	0.0	0.0	0.0	0.0	0.0	0.0	0.0	0.0
Total Delay	306.0	30.0	3.5	22.4	39.5	45.1	31.2	4.9	28.0	32.6	39.0
Queue Length 50th (m)	~169.6	128.2	0.0	6.7	96.4	37.6	28.4	0.0	8.0	34.7	68.2
Queue Length 95th (m)	#253.8	#162.0	15.4	15.3	113.1	57.2	41.3	7.7	15.5	49.2	103.4
Internal Link Dist (m)		507.8			328.1		418.0			489.9	
Turn Bay Length (m)	170.0		100.0	150.0		120.0		50.0	80.0		170.0
Base Capacity (vph)	369	2378	935	164	1666	383	703	589	382	683	686
Starvation Cap Reductn	0	0	0	0	0	0	0	0	0	0	0
Spillback Cap Reductn	0	0	0	0	0	0	0	0	0	0	0
Storage Cap Reductn	0	0	0	0	0	0	0	0	0	0	0
Reduced v/c Ratio	1.60	0.78	0.36	0.35	0.74	0.54	0.25	0.14	0.14	0.31	0.76

Intersection Summary

~ Volume exceeds capacity, queue is theoretically infinite.

Queue shown is maximum after two cycles.

# 95th percentile volume exceeds capacity, queue may be longer.

Queue shown is maximum after two cycles.

Queues  
102: Dixie Rd & Mayfield Rd

2032 Future Total Conditions (Mitigation)  
AM Peak Hour



Lane Group	EBL	EBT	EBR	WBL	WBT	NBL	NBT	NBR	SBL	SBT	SBR
Lane Group Flow (vph)	589	1850	341	57	1225	206	177	81	52	211	518
v/c Ratio	0.72	0.65	0.33	0.36	0.66	0.91	0.38	0.19	0.22	0.46	0.68
Control Delay	27.8	23.2	2.5	23.2	39.0	94.0	47.1	7.0	44.1	49.4	8.5
Queue Delay	0.0	0.0	0.0	0.0	0.0	0.0	0.0	0.0	0.0	0.0	0.0
Total Delay	27.8	23.2	2.5	23.2	39.0	94.0	47.1	7.0	44.1	49.4	8.5
Queue Length 50th (m)	46.9	131.3	0.0	5.1	100.1	53.9	39.3	0.0	11.1	48.0	1.0
Queue Length 95th (m)	66.0	151.4	13.1	12.0	133.8	#89.1	57.2	10.0	21.4	68.0	29.4
Internal Link Dist (m)		507.8			328.1		418.0			489.9	
Turn Bay Length (m)	170.0		100.0	150.0		120.0		50.0	80.0		170.0
Base Capacity (vph)	1042	2830	1048	159	1864	266	550	479	273	534	801
Starvation Cap Reductn	0	0	0	0	0	0	0	0	0	0	0
Spillback Cap Reductn	0	0	0	0	0	0	0	0	0	0	0
Storage Cap Reductn	0	0	0	0	0	0	0	0	0	0	0
Reduced v/c Ratio	0.57	0.65	0.33	0.36	0.66	0.77	0.32	0.17	0.19	0.40	0.65

Intersection Summary

# 95th percentile volume exceeds capacity, queue may be longer.  
Queue shown is maximum after two cycles.

Queues

2032 Future Total Conditions

104: Mayfield Rd & 12035 Dixie Rd Development Access

AM Peak Hour













Lane Group	EBL	EBT	WBT	SBT
Lane Group Flow (vph)	98	1884	1273	38
v/c Ratio	0.28	0.45	0.46	0.25
Control Delay	14.0	12.3	3.2	22.5
Queue Delay	0.0	0.0	0.0	0.0
Total Delay	14.0	12.3	3.2	22.5
Queue Length 50th (m)	15.4	118.9	34.7	0.6
Queue Length 95th (m)	m24.9	150.4	50.2	10.4
Internal Link Dist (m)		328.1	608.7	157.9
Turn Bay Length (m)	50.0			
Base Capacity (vph)	346	4219	2761	635
Starvation Cap Reductn	0	0	0	0
Spillback Cap Reductn	0	0	0	0
Storage Cap Reductn	0	0	0	0
Reduced v/c Ratio	0.28	0.45	0.46	0.06

Intersection Summary

m Volume for 95th percentile queue is metered by upstream signal.

Queues  
101: Bramalea Rd & Mayfield Rd

2032 Future Total Conditions  
PM Peak Hour

											
Lane Group	EBL	EBT	EBR	WBL	WBT	WBR	NBL	NBT	NBR	SBL	SBT
Lane Group Flow (vph)	171	1146	174	144	1236	30	317	209	72	32	238
v/c Ratio	0.76	0.48	0.20	0.79	0.59	0.04	0.86	0.33	0.13	0.07	0.18
Control Delay	42.4	22.6	3.6	65.3	30.7	0.1	62.0	32.6	5.3	20.5	12.6
Queue Delay	0.0	0.0	0.0	0.0	0.0	0.0	0.0	0.0	0.0	0.0	0.0
Total Delay	42.4	22.6	3.6	65.3	30.7	0.1	62.0	32.6	5.3	20.5	12.6
Queue Length 50th (m)	21.4	67.4	0.0	30.5	85.5	0.0	69.0	36.7	0.0	4.2	9.5
Queue Length 95th (m)	#52.4	87.6	11.8	#72.4	108.8	0.0	#106.0	55.1	7.7	9.7	16.9
Internal Link Dist (m)		182.8			347.4			479.0			343.8
Turn Bay Length (m)	180.0		110.0	80.0		100.0	100.0			110.0	
Base Capacity (vph)	226	2389	873	183	2078	678	471	806	708	447	1701
Starvation Cap Reductn	0	0	0	0	0	0	0	0	0	0	0
Spillback Cap Reductn	0	0	0	0	0	0	0	0	0	0	0
Storage Cap Reductn	0	0	0	0	0	0	0	0	0	0	0
Reduced v/c Ratio	0.76	0.48	0.20	0.79	0.59	0.04	0.67	0.26	0.10	0.07	0.14

Intersection Summary

# 95th percentile volume exceeds capacity, queue may be longer.  
Queue shown is maximum after two cycles.

Queues  
102: Dixie Rd & Mayfield Rd

2032 Future Total Conditions  
PM Peak Hour



Lane Group	EBL	EBT	EBR	WBL	WBT	NBL	NBT	NBR	SBL	SBT	SBR
Lane Group Flow (vph)	575	1650	295	97	1908	275	276	78	88	219	699
v/c Ratio	1.94	0.83	0.35	0.58	1.18	0.69	0.39	0.13	0.26	0.31	0.97
Control Delay	459.5	35.7	3.7	27.2	115.8	41.5	29.2	4.3	28.0	27.6	50.0
Queue Delay	0.0	0.0	0.0	0.0	0.0	0.0	0.0	0.0	0.0	0.0	0.0
Total Delay	459.5	35.7	3.7	27.2	115.8	41.5	29.2	4.3	28.0	27.6	50.0
Queue Length 50th (m)	~183.4	116.0	0.0	8.7	~182.1	49.0	42.8	0.0	12.9	32.7	100.4
Queue Length 95th (m)	#246.2	134.6	14.7	m12.8	#209.4	78.7	63.6	7.1	25.0	50.3	#176.5
Internal Link Dist (m)		507.8			328.1		418.0			489.9	
Turn Bay Length (m)	170.0		100.0	150.0		120.0		50.0	80.0		170.0
Base Capacity (vph)	296	1980	838	167	1623	409	716	605	345	723	727
Starvation Cap Reductn	0	0	0	0	0	0	0	0	0	0	0
Spillback Cap Reductn	0	0	0	0	0	0	0	0	0	0	0
Storage Cap Reductn	0	0	0	0	0	0	0	0	0	0	0
Reduced v/c Ratio	1.94	0.83	0.35	0.58	1.18	0.67	0.39	0.13	0.26	0.30	0.96

Intersection Summary

~ Volume exceeds capacity, queue is theoretically infinite.

Queue shown is maximum after two cycles.

# 95th percentile volume exceeds capacity, queue may be longer.

Queue shown is maximum after two cycles.

m Volume for 95th percentile queue is metered by upstream signal.

Queues  
102: Dixie Rd & Mayfield Rd

2032 Future Total Conditions (Mitigation)  
PM Peak Hour



Lane Group	EBL	EBT	EBR	WBL	WBT	NBL	NBT	NBR	SBL	SBT	SBR
Lane Group Flow (vph)	575	1650	295	97	1908	275	276	78	88	219	699
v/c Ratio	0.92	0.68	0.31	0.51	0.96	0.95	0.49	0.16	0.37	0.38	0.94
Control Delay	65.9	29.0	2.9	24.5	54.9	90.9	45.5	7.9	45.5	42.8	53.8
Queue Delay	0.0	0.0	0.0	0.0	0.0	0.0	0.0	0.0	0.0	0.0	0.0
Total Delay	65.9	29.0	2.9	24.5	54.9	90.9	45.5	7.9	45.5	42.8	53.8
Queue Length 50th (m)	68.3	125.0	0.0	10.4	185.3	71.9	60.4	0.0	18.5	46.2	161.6
Queue Length 95th (m)	#104.0	140.8	13.6	18.4	#217.2	#121.5	85.8	10.9	34.1	67.7	#250.8
Internal Link Dist (m)		507.8			328.1		418.0			489.9	
Turn Bay Length (m)	170.0		100.0	150.0		120.0		50.0	80.0		170.0
Base Capacity (vph)	623	2436	963	196	1996	308	598	512	248	603	742
Starvation Cap Reductn	0	0	0	0	0	0	0	0	0	0	0
Spillback Cap Reductn	0	0	0	0	0	0	0	0	0	0	0
Storage Cap Reductn	0	0	0	0	0	0	0	0	0	0	0
Reduced v/c Ratio	0.92	0.68	0.31	0.49	0.96	0.89	0.46	0.15	0.35	0.36	0.94

Intersection Summary

# 95th percentile volume exceeds capacity, queue may be longer.  
Queue shown is maximum after two cycles.

Queues

2032 Future Total Conditions

104: Mayfield Rd & 12035 Dixie Rd Development Access

PM Peak Hour



Lane Group	EBL	EBT	WBT	SBT
Lane Group Flow (vph)	43	1773	1903	131
v/c Ratio	0.38	0.50	0.73	0.59
Control Delay	25.8	12.2	10.4	46.2
Queue Delay	0.0	0.0	0.0	0.0
Total Delay	25.8	12.2	10.4	46.2
Queue Length 50th (m)	4.4	69.2	98.2	19.8
Queue Length 95th (m)	m7.0	90.2	151.8	36.4
Internal Link Dist (m)		328.1	608.7	157.9
Turn Bay Length (m)	50.0			
Base Capacity (vph)	113	3577	2606	620
Starvation Cap Reductn	0	0	0	0
Spillback Cap Reductn	0	0	0	0
Storage Cap Reductn	0	0	0	0
Reduced v/c Ratio	0.38	0.50	0.73	0.21

Intersection Summary

m Volume for 95th percentile queue is metered by upstream signal.

# **Appendix H**

## Swept Path Analysis

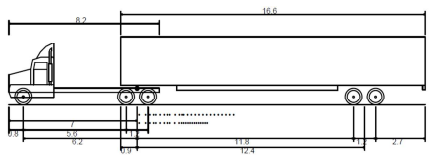

WB-20-180 - Tractor & Semi-Trailer  
 Overall Length 22.700m  
 Overall Width 2.600m  
 Overall Body Height 3.730m  
 Min Body Ground Clearance 0.435m  
 Track Width 2.600m  
 Lock-to-lock time 4.00s  
 Curb to Curb Turning Radius 14.300m

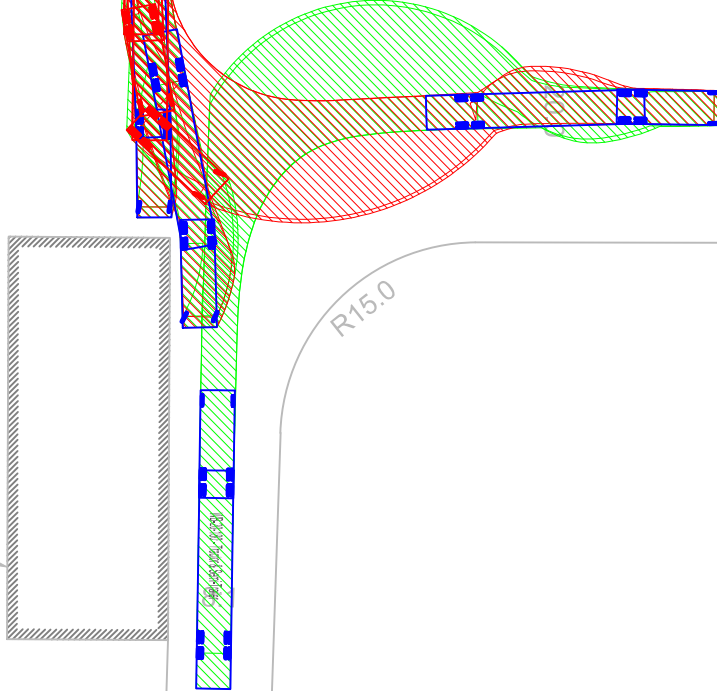

Existing Building

R15.0

EPA2 Boundary

Unevaluated

REV.	SUBMISSION	DATE	INITIAL

**4848 Mayfield Road  
 Traffic Impact Study**



DESIGN	DRAWN	CHECKED	CONTRACT No.
SCALE:	DRAWING NUMBER		WB-20 - Tractor & Semi-Trailer Ingress # 1
DATE:			

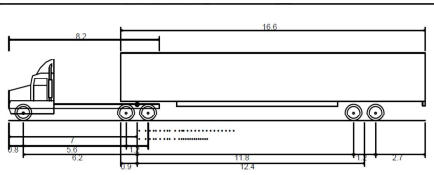

WB-20-180 - Tractor & Semi-Trailer  
 Overall Length 22.700m  
 Overall Width 2.600m  
 Overall Body Height 3.730m  
 Min Body Ground Clearance 0.435m  
 Track Width 2.600m  
 Lock-to-lock time 4.00s  
 Curb to Curb Turning Radius 14.300m

Existing Building

Limit of Grading



Trailer Parking

15

20.0

R15.0

EPA2 Boundary

10.0

Unevalua

10.0

REV.	SUBMISSION	DATE	INITIAL

**4848 Mayfield Road  
 Traffic Impact Study**



DESIGN	DRAWN	CHECKED	CONTRACT No.
SCALE:	DRAWING NUMBER		WB-20 - Tractor & Semi-Trailer Egress # 1
DATE:			

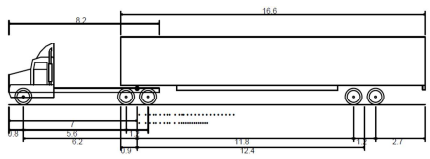

WB-20-180 - Tractor & Semi-Trailer  
 Overall Length 22.700m  
 Overall Width 2.600m  
 Overall Body Height 3.730m  
 Min Body Ground Clearance 0.435m  
 Track Width 2.600m  
 Lock-to-lock time 4.00s  
 Curb to Curb Turning Radius 14.300m

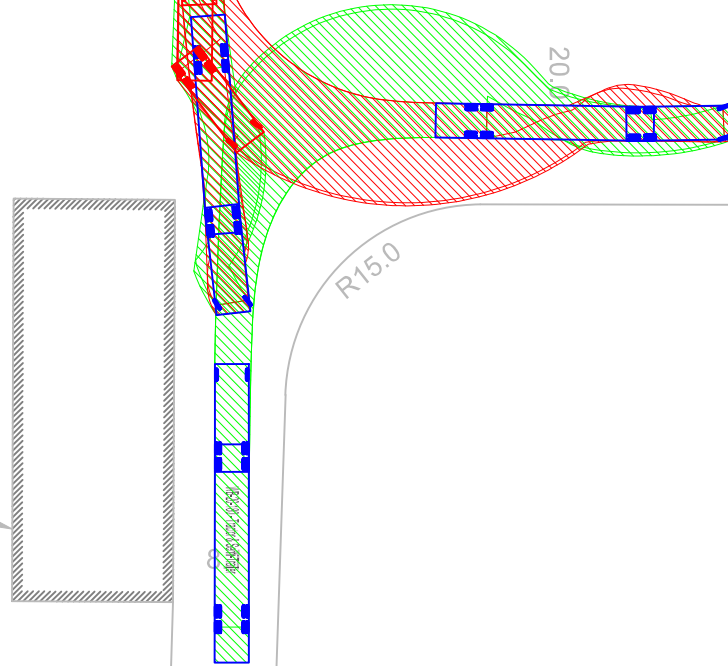
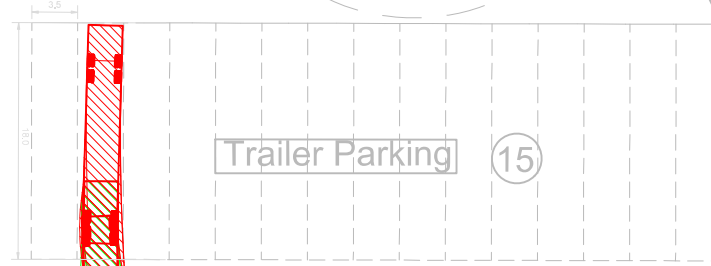

Existing Building

EPA2 Boundary

Unevaluated

REV.	SUBMISSION	DATE	INITIAL

**4848 Mayfield Road  
 Traffic Impact Study**



DESIGN	DRAWN	CHECKED	CONTRACT No.
SCALE:	DRAWING NUMBER		WB-20 - Tractor & Semi-Trailer Ingress # 2
DATE:			

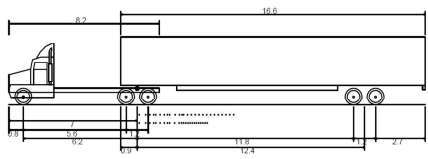

WB-20-180 - Tractor & Semi-Trailer  
 Overall Length 22.700m  
 Overall Width 2.600m  
 Overall Body Height 3.730m  
 Min Body Ground Clearance 0.435m  
 Track Width 2.600m  
 Lock-to-lock time 4.00s  
 Curb to Curb Turning Radius 14.300m

Existing Building

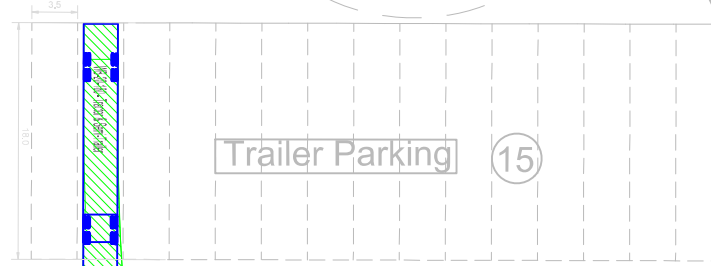

EPA2 Boundary

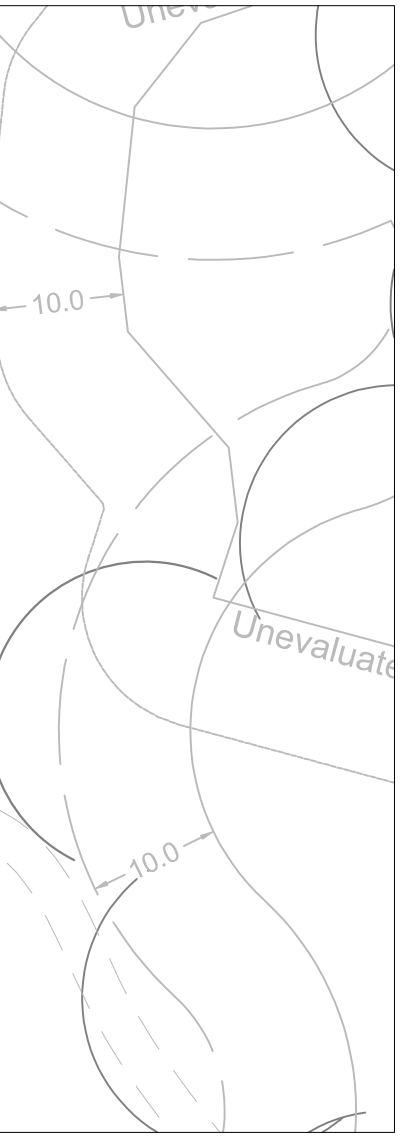

**4848 Mayfield Road  
 Traffic Impact Study**



DESIGN	DRAWN	CHECKED	CONTRACT No.
SCALE:	DRAWING NUMBER		WB-20 - Tractor & Semi-Trailer Egress # 2
DATE:			

REV.	SUBMISSION	DATE	INITIAL

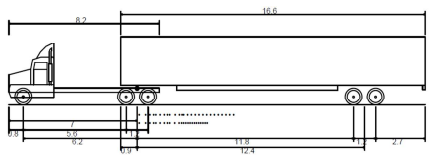

WB-20-180 - Tractor & Semi-Trailer  
 Overall Length 22.700m  
 Overall Width 2.600m  
 Overall Body Height 3.730m  
 Min Body Ground Clearance 0.435m  
 Track Width 2.600m  
 Lock-to-lock time 4.00s  
 Curb to Curb Turning Radius 14.300m



EPA2 Boundary

10.0

Unevaluated

10.0

Existing Building

R15.0

8.0

**4848 Mayfield Road  
 Traffic Impact Study**



DESIGN	DRAWN	CHECKED	CONTRACT No.
SCALE:	DRAWING NUMBER		WB-20 - Tractor & Semi-Trailer Ingress # 3
DATE:			

REV.	SUBMISSION	DATE	INITIAL

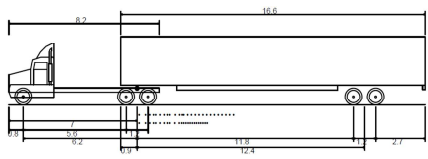

WB-20-180 - Tractor & Semi-Trailer  
 Overall Length 22.700m  
 Overall Width 2.600m  
 Overall Body Height 3.730m  
 Min Body Ground Clearance 0.435m  
 Track Width 2.600m  
 Lock-to-lock time 4.00s  
 Curb to Curb Turning Radius 14.300m

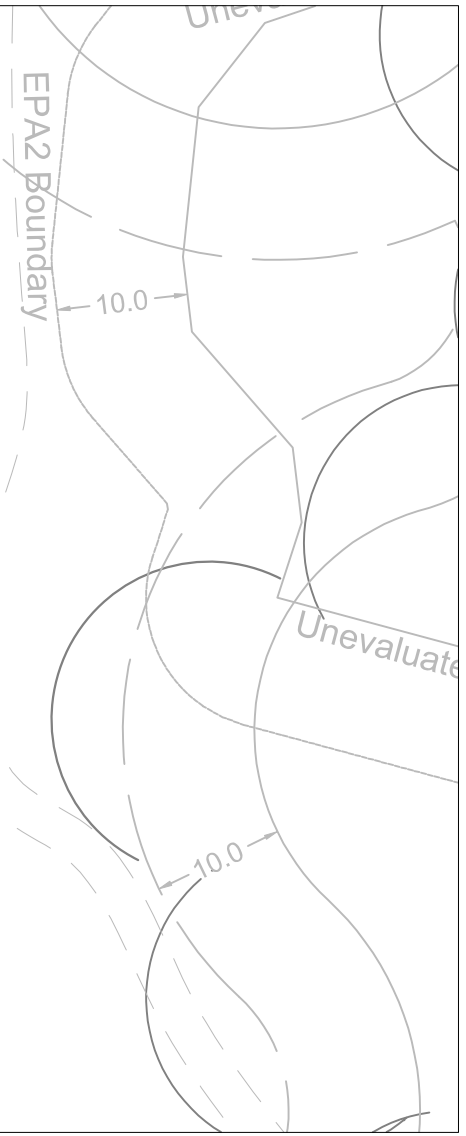
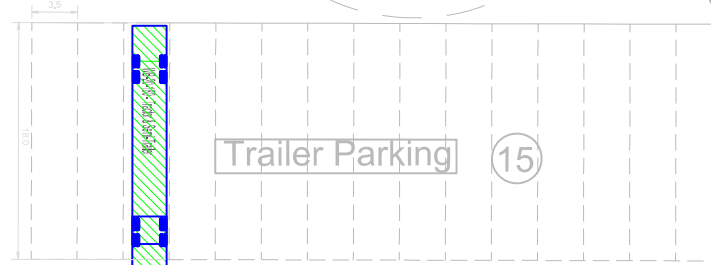

Existing Building



R15.0

20.0

8.0

REV.	SUBMISSION	DATE	INITIAL

**4848 Mayfield Road  
 Traffic Impact Study**



DESIGN	DRAWN	CHECKED	CONTRACT No.
SCALE:	DRAWING NUMBER		WB-20 - Tractor & Semi-Trailer Egress # 3
DATE:			

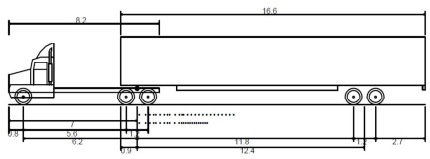

WB-20-180 - Tractor & Semi-Trailer  
 Overall Length 22.700m  
 Overall Width 2.600m  
 Overall Body Height 3.730m  
 Min Body Ground Clearance 0.435m  
 Track Width 2.600m  
 Lock-to-lock time 4.00s  
 Curb to Curb Turning Radius 14.300m

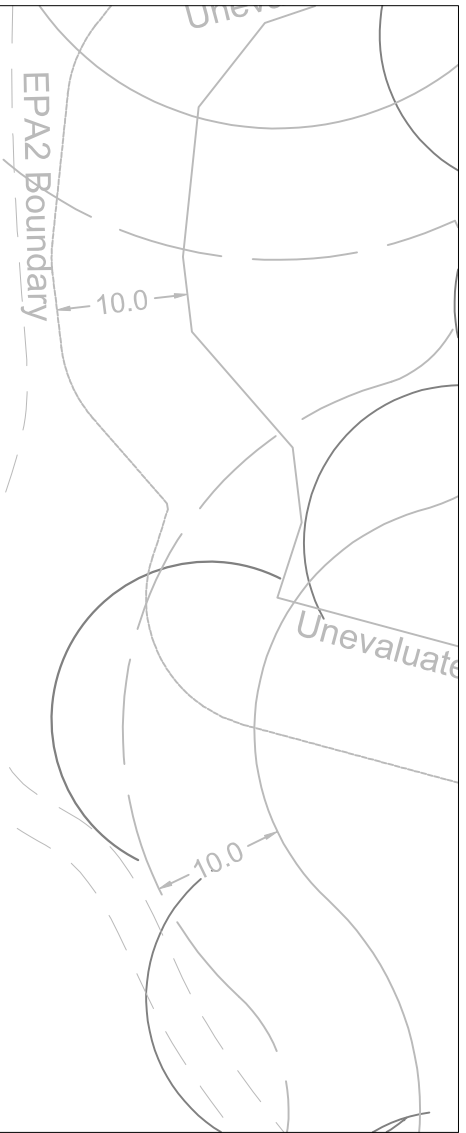

Existing Building



R15.0

8.0

**4848 Mayfield Road  
 Traffic Impact Study**



DESIGN	DRAWN	CHECKED	CONTRACT No.
SCALE:	DRAWING NUMBER		WB-20 - Tractor & Semi-Trailer Ingress # 4
DATE:			

REV.	SUBMISSION	DATE	INITIAL

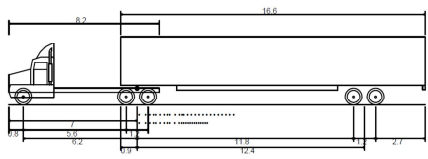

WB-20-180 - Tractor & Semi-Trailer  
 Overall Length 22.700m  
 Overall Width 2.600m  
 Overall Body Height 3.730m  
 Min Body Ground Clearance 0.435m  
 Track Width 2.600m  
 Lock-to-lock time 4.00s  
 Curb to Curb Turning Radius 14.300m

Existing Building



REV.	SUBMISSION	DATE	INITIAL

**4848 Mayfield Road  
 Traffic Impact Study**



DESIGN	DRAWN	CHECKED	CONTRACT No.
SCALE:	DRAWING NUMBER		WB-20 - Tractor & Semi-Trailer Egress # 4
DATE:			

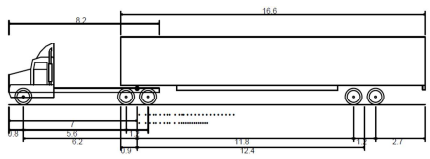

WB-20-180 - Tractor & Semi-Trailer  
 Overall Length 22.700m  
 Overall Width 2.600m  
 Overall Body Height 3.730m  
 Min Body Ground Clearance 0.435m  
 Track Width 2.600m  
 Lock-to-lock time 4.00s  
 Curb to Curb Turning Radius 14.300m

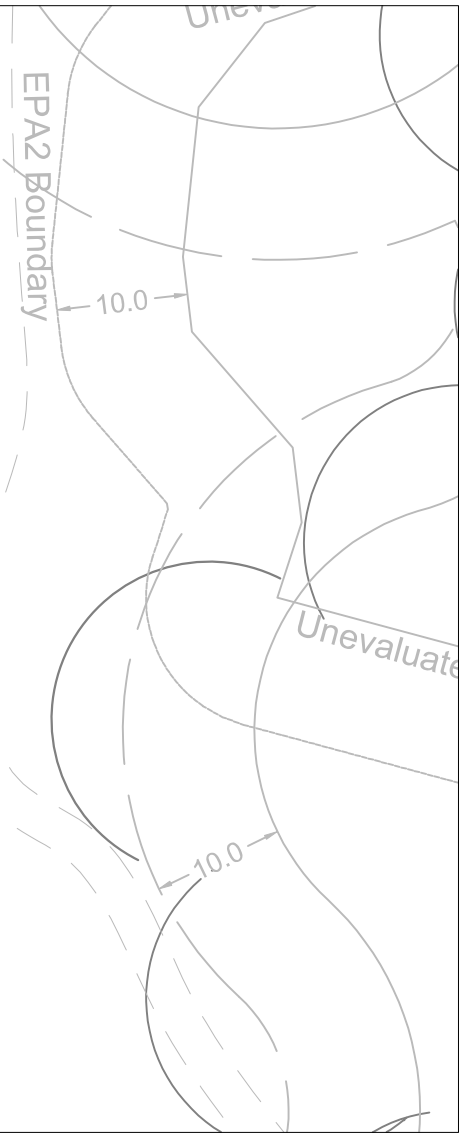

Existing Building



R15.0

8.0

**4848 Mayfield Road  
 Traffic Impact Study**



DESIGN	DRAWN	CHECKED	CONTRACT No.
SCALE:	DRAWING NUMBER		WB-20 - Tractor & Semi-Trailer Ingress # 5
DATE:			

REV.	SUBMISSION	DATE	INITIAL

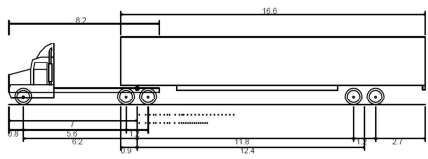

WB-20-180 - Tractor & Semi-Trailer  
 Overall Length 22.700m  
 Overall Width 2.600m  
 Overall Body Height 3.730m  
 Min Body Ground Clearance 0.435m  
 Track Width 2.600m  
 Lock-to-lock time 4.00s  
 Curb to Curb Turning Radius 14.300m

Existing Building

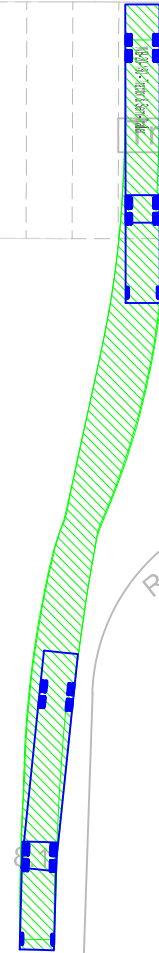
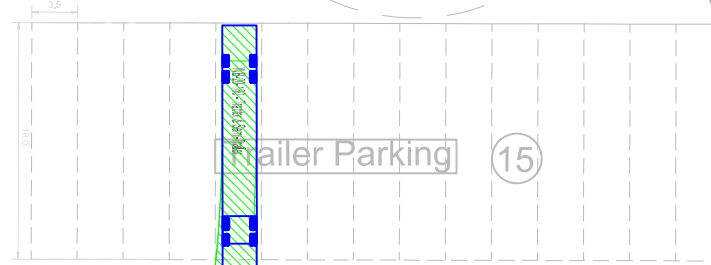

20.0

R15.0

EPA2 Boundary

10.0

Unevaluated

10.0

8.0

**4848 Mayfield Road  
 Traffic Impact Study**



DESIGN	DRAWN	CHECKED	CONTRACT No.
SCALE:	DRAWING NUMBER		WB-20 - Tractor & Semi-Trailer Egress # 5
DATE:			

REV.	SUBMISSION	DATE	INITIAL

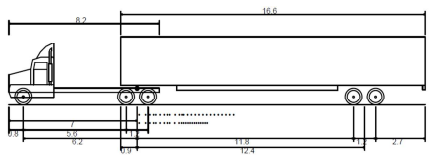

WB-20-180 - Tractor & Semi-Trailer  
 Overall Length 22.700m  
 Overall Width 2.600m  
 Overall Body Height 3.730m  
 Min Body Ground Clearance 0.435m  
 Track Width 2.600m  
 Lock-to-lock time 4.00s  
 Curb to Curb Turning Radius 14.300m

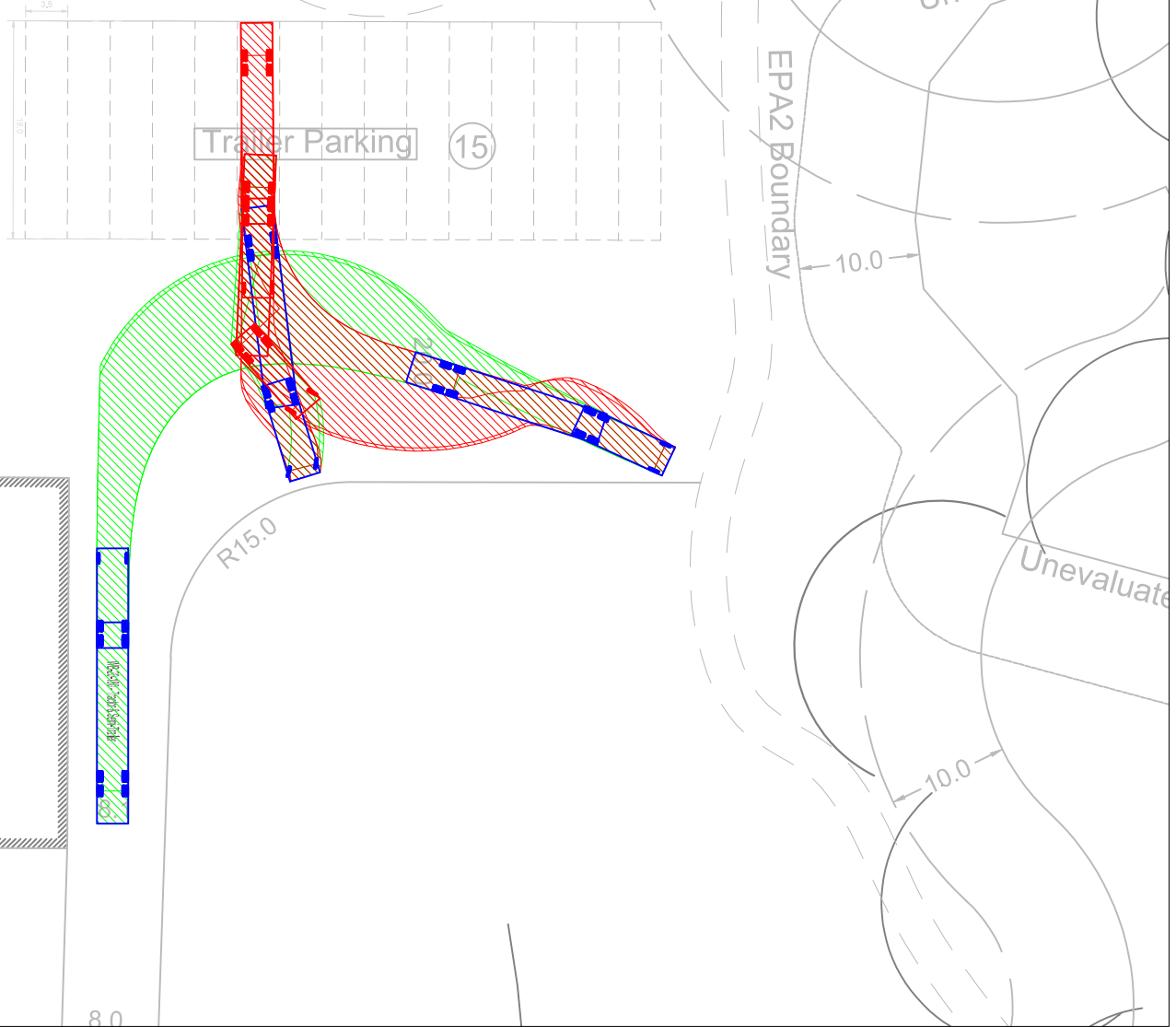

REV.	SUBMISSION	DATE	INITIAL

**4848 Mayfield Road  
 Traffic Impact Study**



DESIGN	DRAWN	CHECKED	CONTRACT No.
SCALE:	DRAWING NUMBER		WB-20 - Tractor & Semi-Trailer Ingress # 6
DATE:			

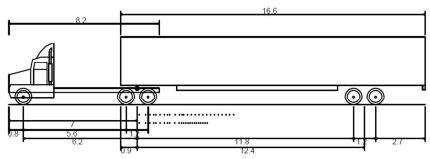

WB-20-180 - Tractor & Semi-Trailer  
 Overall Length 22.700m  
 Overall Width 2.600m  
 Overall Body Height 3.730m  
 Min Body Ground Clearance 0.435m  
 Track Width 2.600m  
 Lock-to-lock time 4.00s  
 Curb to Curb Turning Radius 14.300m

Existing Building

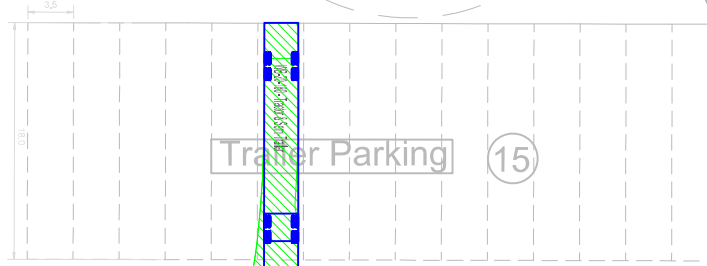

20.0

R15.0

EPA2 Boundary

10.0

Unevaluated

10.0

8.0

**4848 Mayfield Road  
 Traffic Impact Study**



DESIGN	DRAWN	CHECKED	CONTRACT No.
SCALE:	DRAWING NUMBER		WB-20 - Tractor & Semi-Trailer Egress # 6
DATE:			

REV.	SUBMISSION	DATE	INITIAL

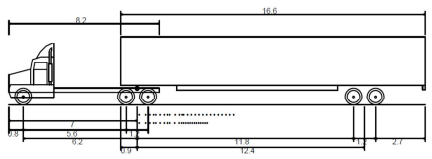

WB-20-180 - Tractor & Semi-Trailer  
 Overall Length 22.700m  
 Overall Width 2.600m  
 Overall Body Height 3.730m  
 Min Body Ground Clearance 0.435m  
 Track Width 2.600m  
 Lock-to-lock time 4.00s  
 Curb to Curb Turning Radius 14.300m

Limit of Grading

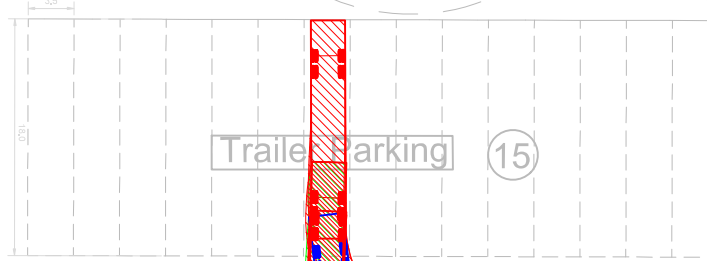

EPA2 Boundary

Unevaluated Wet

Unevaluat

Existing Building

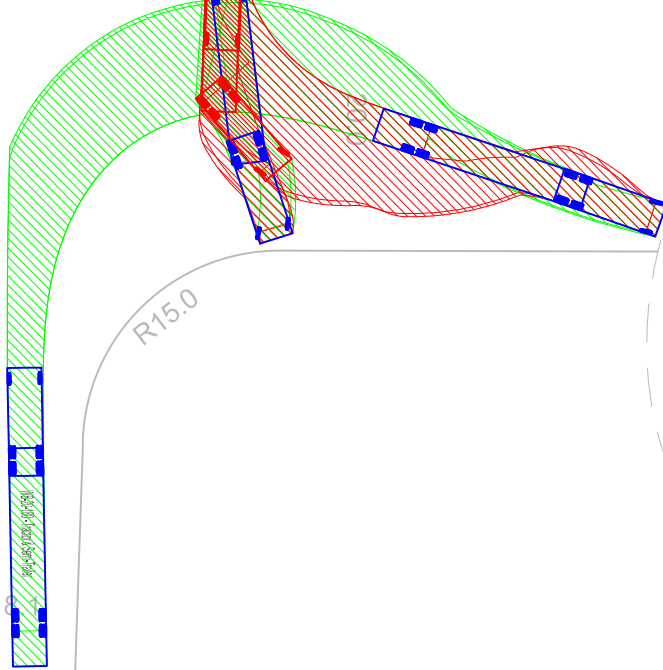

REV.	SUBMISSION	DATE	INITIAL

**4848 Mayfield Road  
 Traffic Impact Study**



DESIGN	DRAWN	CHECKED	CONTRACT No.
SCALE:	DRAWING NUMBER		WB-20 - Tractor & Semi-Trailer Ingress # 7
DATE:			

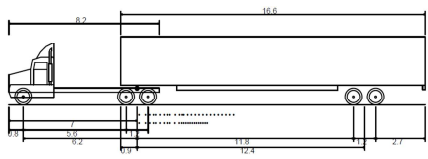

WB-20-180 - Tractor & Semi-Trailer  
 Overall Length 22.700m  
 Overall Width 2.600m  
 Overall Body Height 3.730m  
 Min Body Ground Clearance 0.435m  
 Track Width 2.600m  
 Lock-to-lock time 4.00s  
 Curb to Curb Turning Radius 14.300m

Existing Building

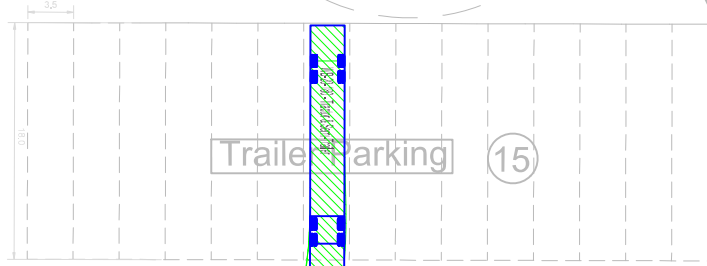

20.0

R15.0

EPA2 Boundary

10.0

Unevaluated

10.0

8.0

REV.	SUBMISSION	DATE	INITIAL

**4848 Mayfield Road  
 Traffic Impact Study**



DESIGN	DRAWN	CHECKED	CONTRACT No.
SCALE:	DRAWING NUMBER		WB-20 - Tractor & Semi-Trailer Egress # 7
DATE:			

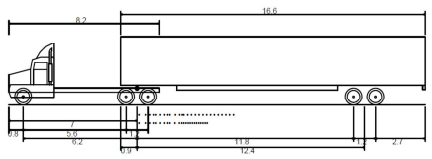

WB-20-180 - Tractor & Semi-Trailer  
 Overall Length 22.700m  
 Overall Width 2.600m  
 Overall Body Height 3.730m  
 Min Body Ground Clearance 0.435m  
 Track Width 2.600m  
 Lock-to-lock time 4.00s  
 Curb to Curb Turning Radius 14.300m

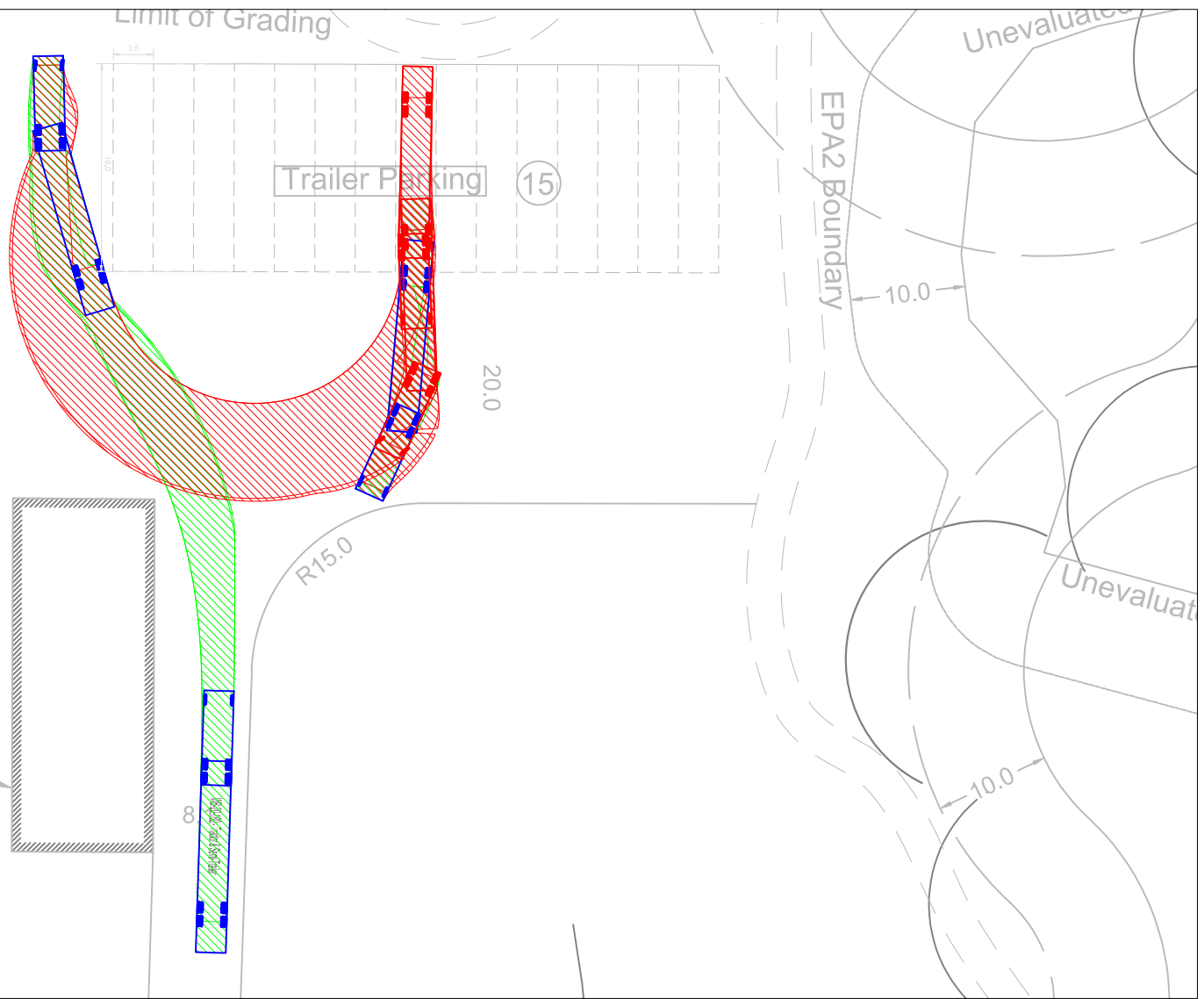

Existing Building

**4848 Mayfield Road  
 Traffic Impact Study**



DESIGN	DRAWN	CHECKED	CONTRACT No.
SCALE:	DRAWING NUMBER		WB-20 - Tractor & Semi-Trailer Ingress # 8
DATE:			

REV.	SUBMISSION	DATE	INITIAL

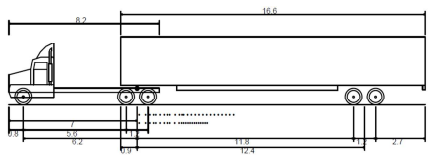

WB-20-180 - Tractor & Semi-Trailer  
 Overall Length 22.700m  
 Overall Width 2.600m  
 Overall Body Height 3.730m  
 Min Body Ground Clearance 0.435m  
 Track Width 2.600m  
 Lock-to-lock time 4.00s  
 Curb to Curb Turning Radius 14.300m

Existing Building

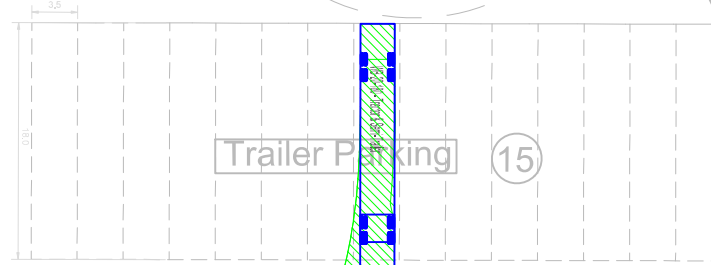

20.0

R15.0

EPA2 Boundary

10.0

Unevaluated

10.0

8.0

**4848 Mayfield Road  
 Traffic Impact Study**



DESIGN	DRAWN	CHECKED	CONTRACT No.
SCALE:	DRAWING NUMBER		WB-20 - Tractor & Semi-Trailer Egress # 8
DATE:			

REV.	SUBMISSION	DATE	INITIAL

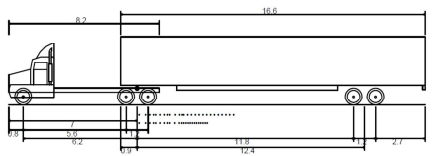

WB-20-180 - Tractor & Semi-Trailer  
 Overall Length 22.700m  
 Overall Width 2.600m  
 Overall Body Height 3.730m  
 Min Body Ground Clearance 0.435m  
 Track Width 2.600m  
 Lock-to-lock time 4.00s  
 Curb to Curb Turning Radius 14.300m

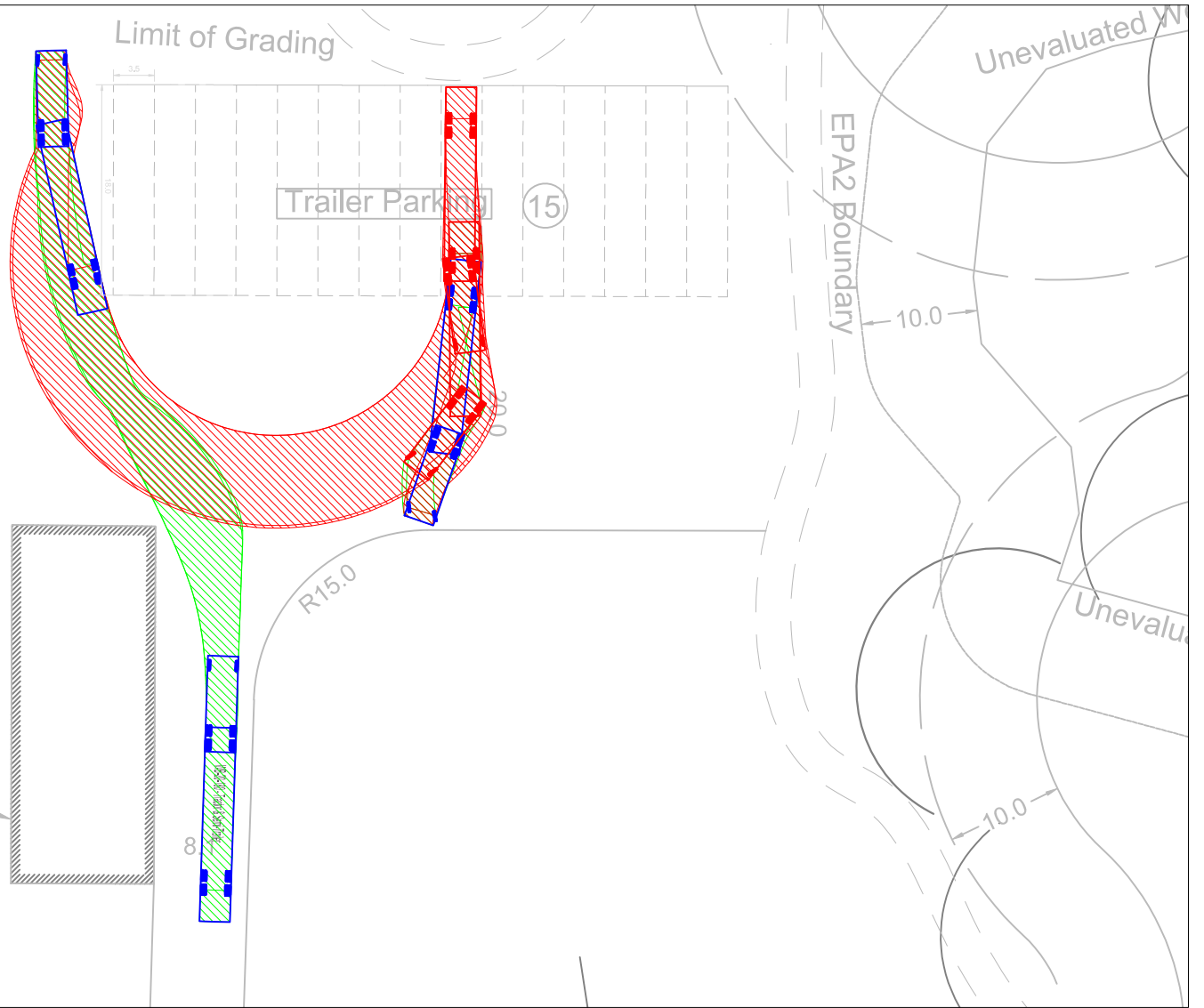

Existing Building

**4848 Mayfield Road  
 Traffic Impact Study**



DESIGN	DRAWN	CHECKED	CONTRACT No.
SCALE:	DRAWING NUMBER		WB-20 - Tractor & Semi-Trailer Ingress # 9
DATE:			

REV.	SUBMISSION	DATE	INITIAL

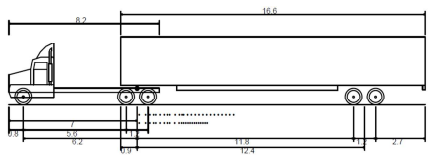

WB-20-180 - Tractor & Semi-Trailer  
 Overall Length 22.700m  
 Overall Width 2.600m  
 Overall Body Height 3.730m  
 Min Body Ground Clearance 0.435m  
 Track Width 2.600m  
 Lock-to-lock time 4.00s  
 Curb to Curb Turning Radius 14.300m



Existing Building



EPA2 Boundary

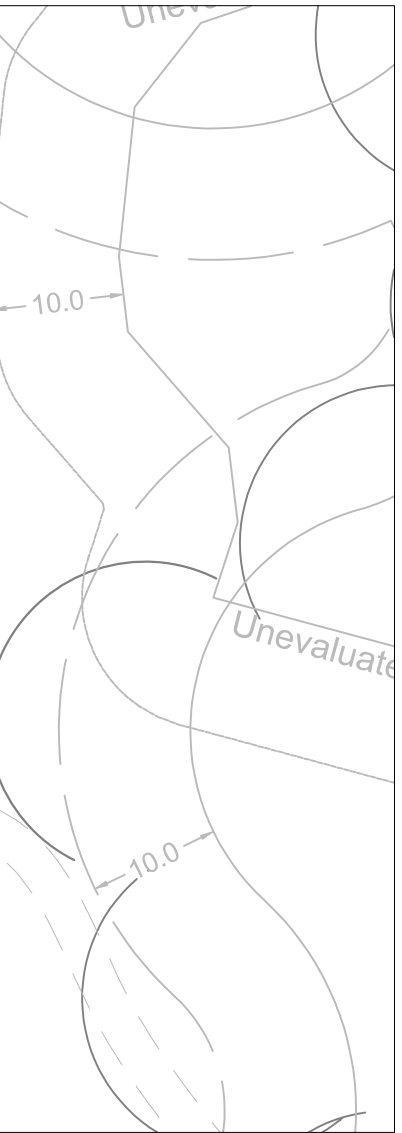

REV.	SUBMISSION	DATE	INITIAL

**4848 Mayfield Road  
 Traffic Impact Study**



DESIGN	DRAWN	CHECKED	CONTRACT No.
SCALE:	DRAWING NUMBER		WB-20 - Tractor & Semi-Trailer Egress # 9
DATE:			

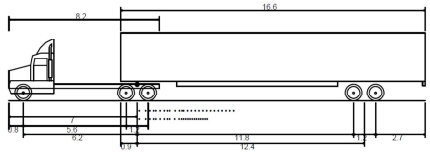

WB-20-180 - Tractor & Semi-Trailer  
 Overall Length 22.700m  
 Overall Width 2.600m  
 Overall Body Height 3.730m  
 Min Body Ground Clearance 0.435m  
 Track Width 2.600m  
 Lock-to-lock time 4.00s  
 Curb to Curb Turning Radius 14.300m

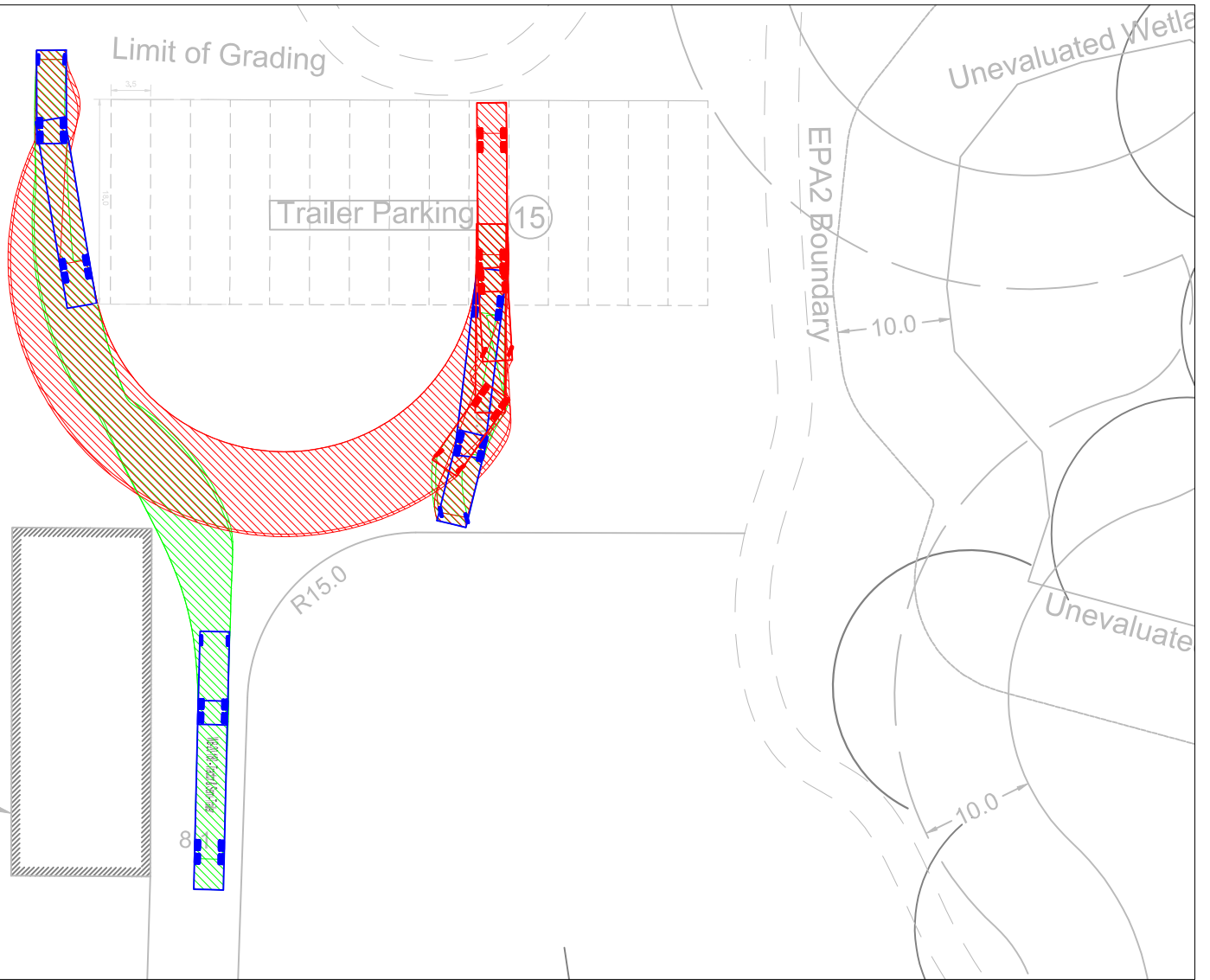

REV.	SUBMISSION	DATE	INITIAL

**4848 Mayfield Road  
 Traffic Impact Study**



DESIGN	DRAWN	CHECKED	CONTRACT No.
SCALE:	DRAWING NUMBER		WB-20 - Tractor & Semi-Trailer Ingress # 10
DATE:			

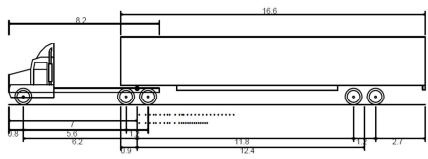

WB-20-180 - Tractor & Semi-Trailer  
 Overall Length 22.700m  
 Overall Width 2.600m  
 Overall Body Height 3.730m  
 Min Body Ground Clearance 0.435m  
 Track Width 2.600m  
 Lock-to-lock time 4.00s  
 Curb to Curb Turning Radius 14.300m



Existing Building



R15.0

EPA2 Boundary

10.0

Unevaluated

10.0

8.0

**4848 Mayfield Road  
 Traffic Impact Study**



DESIGN	DRAWN	CHECKED	CONTRACT No.
SCALE:	DRAWING NUMBER		WB-20 - Tractor & Semi-Trailer Egress # 10
DATE:			

REV.	SUBMISSION	DATE	INITIAL

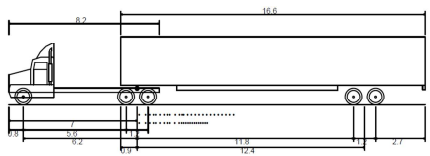

WB-20-180 - Tractor & Semi-Trailer  
 Overall Length 22.700m  
 Overall Width 2.600m  
 Overall Body Height 3.730m  
 Min Body Ground Clearance 0.435m  
 Track Width 2.600m  
 Lock-to-lock time 4.00s  
 Curb to Curb Turning Radius 14.300m

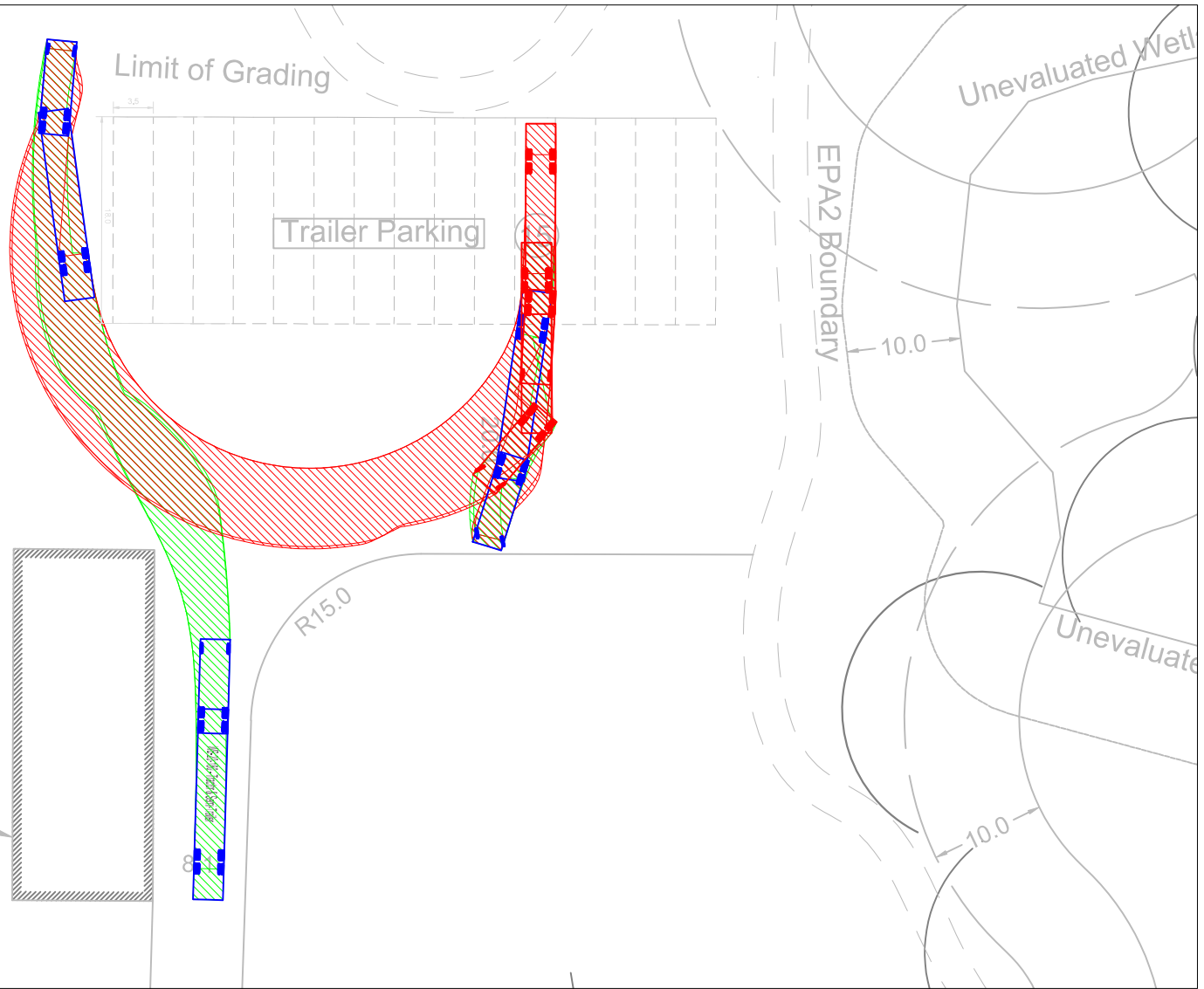

Existing Building

Limit of Grading

Trailer Parking

EPA2 Boundary

Unevaluated Wetland

Unevaluated

R15.0

REV.	SUBMISSION	DATE	INITIAL

**4848 Mayfield Road  
 Traffic Impact Study**



DESIGN	DRAWN	CHECKED	CONTRACT No.
SCALE:	DRAWING NUMBER		WB-20 - Tractor & Semi-Trailer Ingress # 11
DATE:			

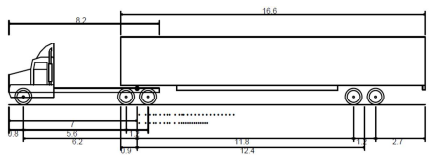

WB-20-180 - Tractor & Semi-Trailer  
 Overall Length 22.700m  
 Overall Width 2.600m  
 Overall Body Height 3.730m  
 Min Body Ground Clearance 0.435m  
 Track Width 2.600m  
 Lock-to-lock time 4.00s  
 Curb to Curb Turning Radius 14.300m



Existing Building

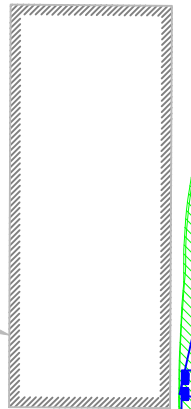

R15.0

EPA2 Boundary

10.0

Unevaluated

10.0

8.0

**4848 Mayfield Road  
 Traffic Impact Study**



DESIGN	DRAWN	CHECKED	CONTRACT No.
SCALE:	DRAWING NUMBER		WB-20 - Tractor & Semi-Trailer Egress # 11
DATE:			

REV.	SUBMISSION	DATE	INITIAL

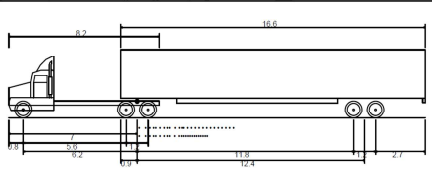

WB-20-180 - Tractor & Semi-Trailer  
 Overall Length 22.700m  
 Overall Width 2.600m  
 Overall Body Height 3.730m  
 Min Body Ground Clearance 0.435m  
 Track Width 2.600m  
 Lock-to-lock time 4.00s  
 Curb to Curb Turning Radius 14.300m

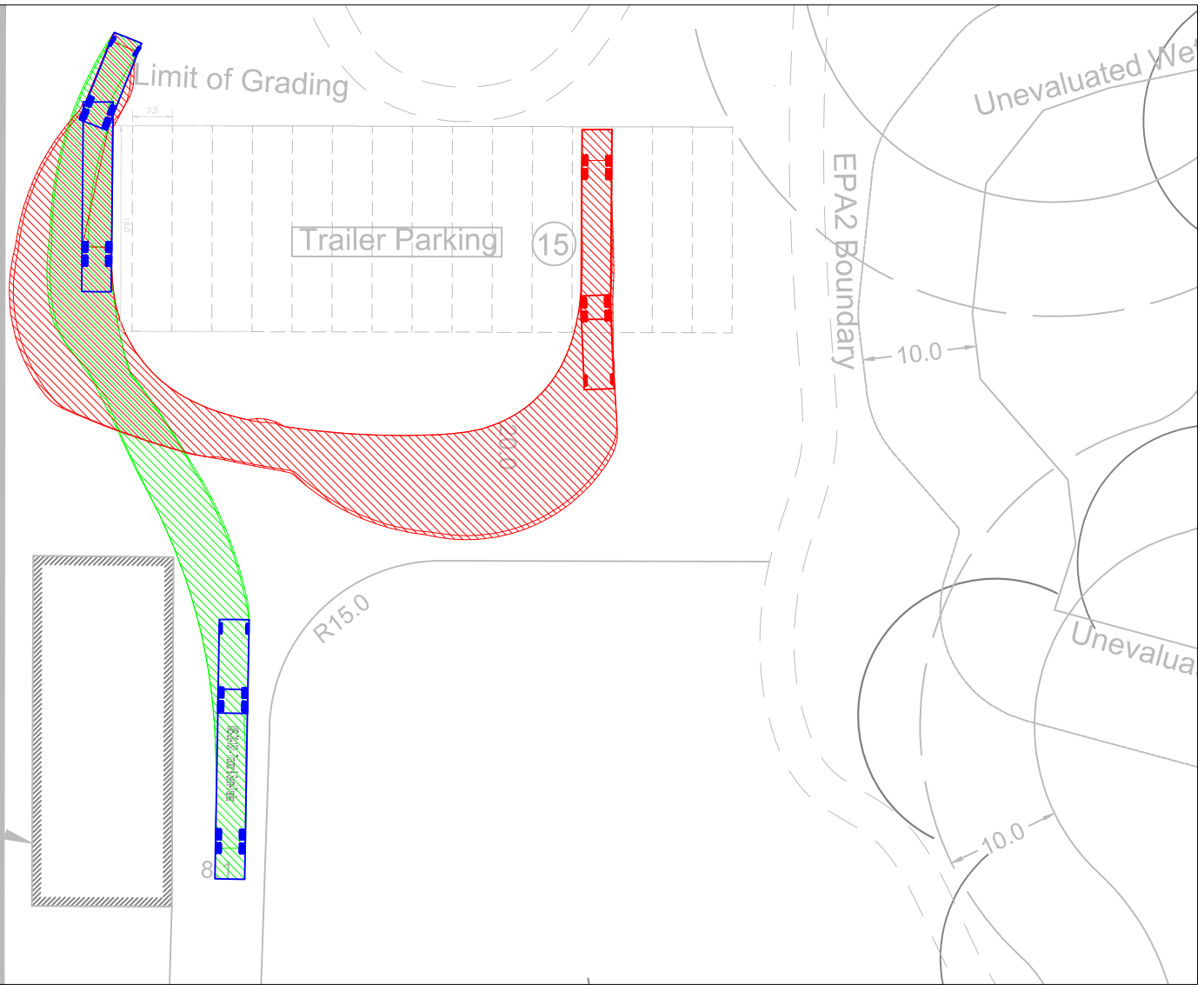

Existing Building

**4848 Mayfield Road  
 Traffic Impact Study**



DESIGN	DRAWN	CHECKED	CONTRACT No.
SCALE:	DRAWING NUMBER		WB-20 - Tractor & Semi-Trailer Ingress # 12
DATE:			

REV.	SUBMISSION	DATE	INITIAL

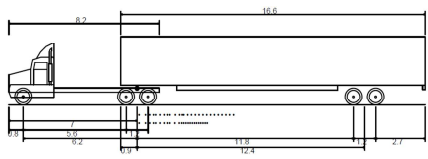

WB-20-180 - Tractor & Semi-Trailer  
 Overall Length 22.700m  
 Overall Width 2.600m  
 Overall Body Height 3.730m  
 Min Body Ground Clearance 0.435m  
 Track Width 2.600m  
 Lock-to-lock time 4.00s  
 Curb to Curb Turning Radius 14.300m

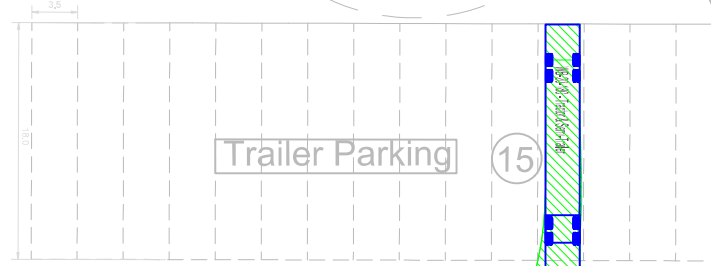

Existing Building



R15.0

EPA2 Boundary

10.0

Unevaluated

10.0

8.0

**4848 Mayfield Road  
 Traffic Impact Study**



DESIGN	DRAWN	CHECKED	CONTRACT No.
SCALE:	DRAWING NUMBER		WB-20 - Tractor & Semi-Trailer Egress # 12
DATE:			

REV.	SUBMISSION	DATE	INITIAL

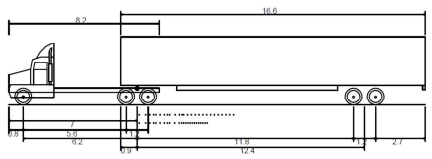

WB-20-180 - Tractor & Semi-Trailer  
 Overall Length 22.700m  
 Overall Width 2.600m  
 Overall Body Height 3.730m  
 Min Body Ground Clearance 0.435m  
 Track Width 2.600m  
 Lock-to-lock time 4.00s  
 Curb to Curb Turning Radius 14.300m

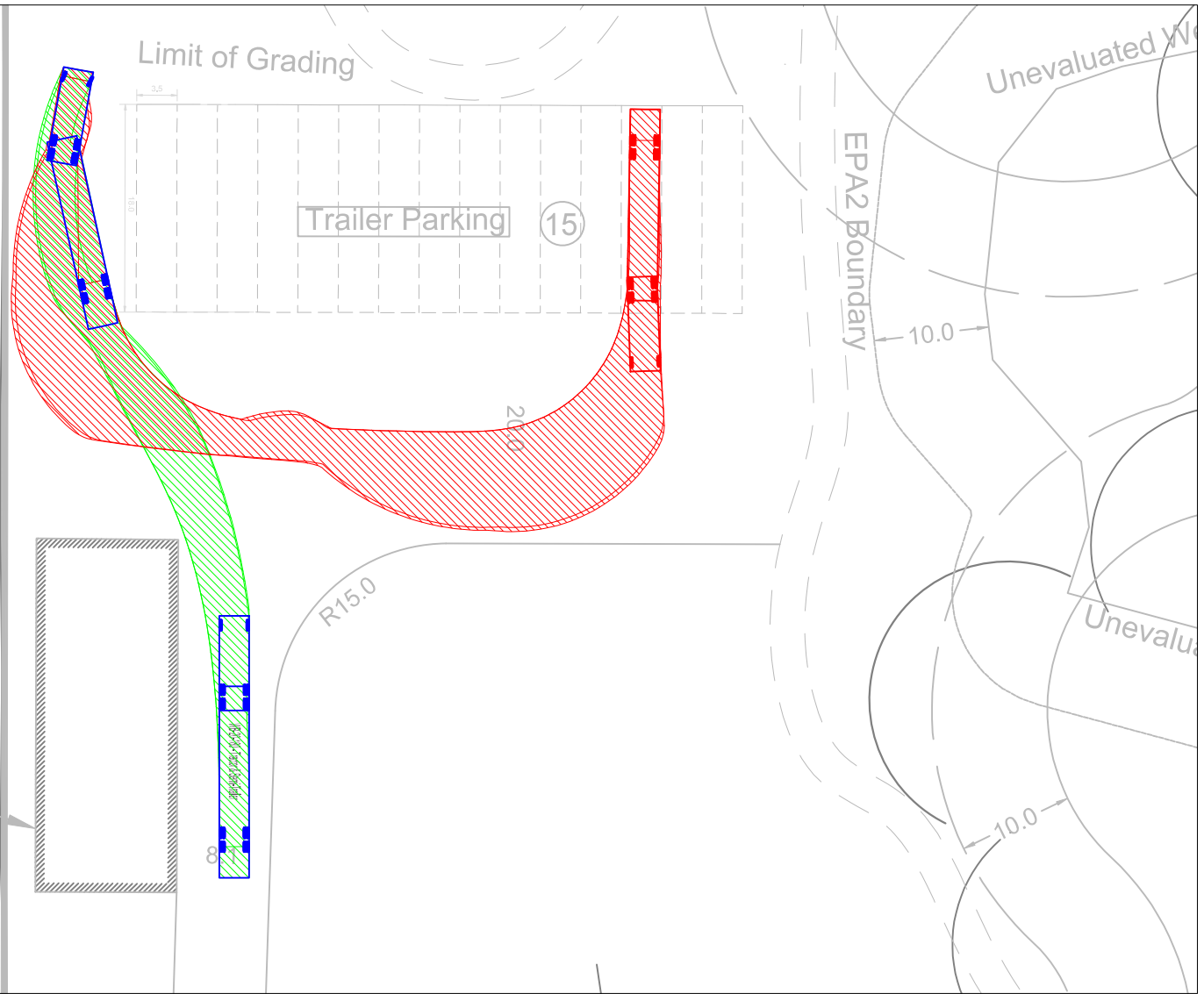

Existing Building

**4848 Mayfield Road  
 Traffic Impact Study**



DESIGN	DRAWN	CHECKED	CONTRACT No.
SCALE:	DRAWING NUMBER		WB-20 - Tractor & Semi-Trailer Ingress # 13
DATE:			

REV.	SUBMISSION	DATE	INITIAL

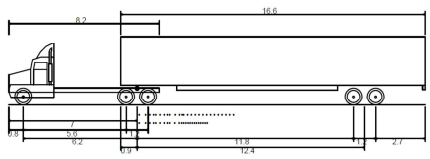

WB-20-180 - Tractor & Semi-Trailer  
 Overall Length 22.700m  
 Overall Width 2.600m  
 Overall Body Height 3.730m  
 Min Body Ground Clearance 0.435m  
 Track Width 2.600m  
 Lock-to-lock time 4.00s  
 Curb to Curb Turning Radius 14.300m



EPA2 Boundary

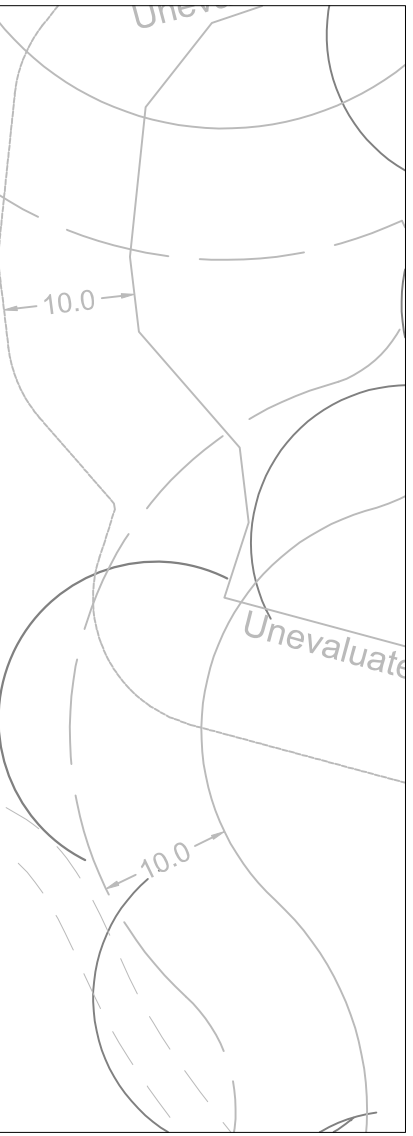

Existing Building



R15.0

20.0

8.0

REV.	SUBMISSION	DATE	INITIAL

**4848 Mayfield Road  
 Traffic Impact Study**



DESIGN	DRAWN	CHECKED	CONTRACT No.
SCALE:	DRAWING NUMBER		WB-20 - Tractor & Semi-Trailer Egress # 13
DATE:			

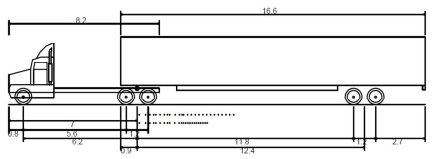

WB-20-180 - Tractor & Semi-Trailer  
 Overall Length 22.700m  
 Overall Width 2.600m  
 Overall Body Height 3.730m  
 Min Body Ground Clearance 0.435m  
 Track Width 2.600m  
 Lock-to-lock time 4.00s  
 Curb to Curb Turning Radius 14.300m

Existing Building

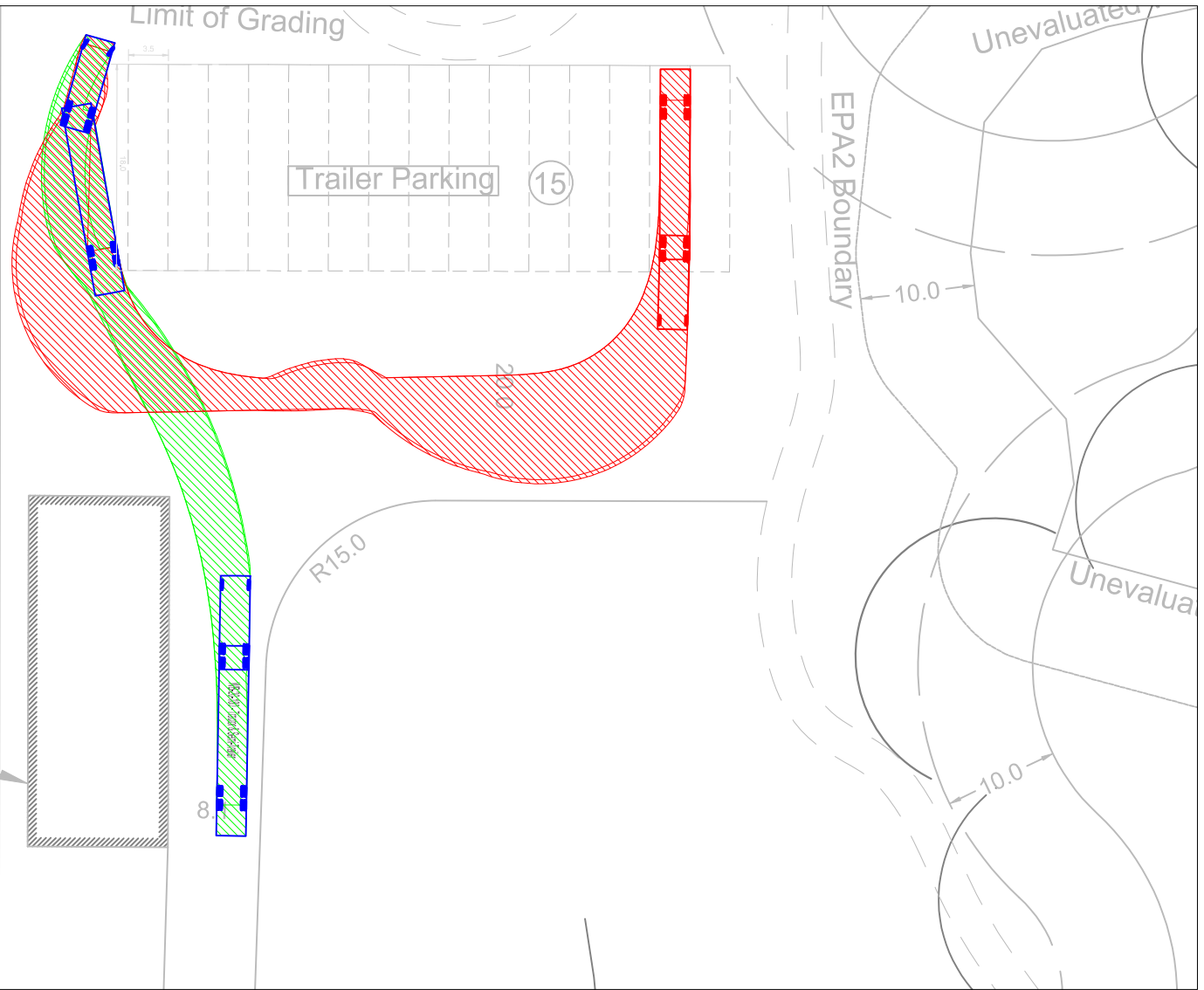

REV.	SUBMISSION	DATE	INITIAL

**4848 Mayfield Road  
 Traffic Impact Study**



DESIGN	DRAWN	CHECKED	CONTRACT No.
SCALE:	DRAWING NUMBER		WB-20 - Tractor & Semi-Trailer Ingress # 14
DATE:			

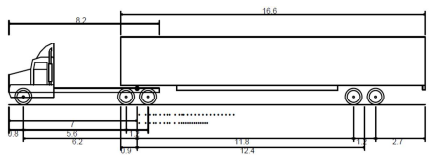

WB-20-180 - Tractor & Semi-Trailer  
 Overall Length 22.700m  
 Overall Width 2.600m  
 Overall Body Height 3.730m  
 Min Body Ground Clearance 0.435m  
 Track Width 2.600m  
 Lock-to-lock time 4.00s  
 Curb to Curb Turning Radius 14.300m

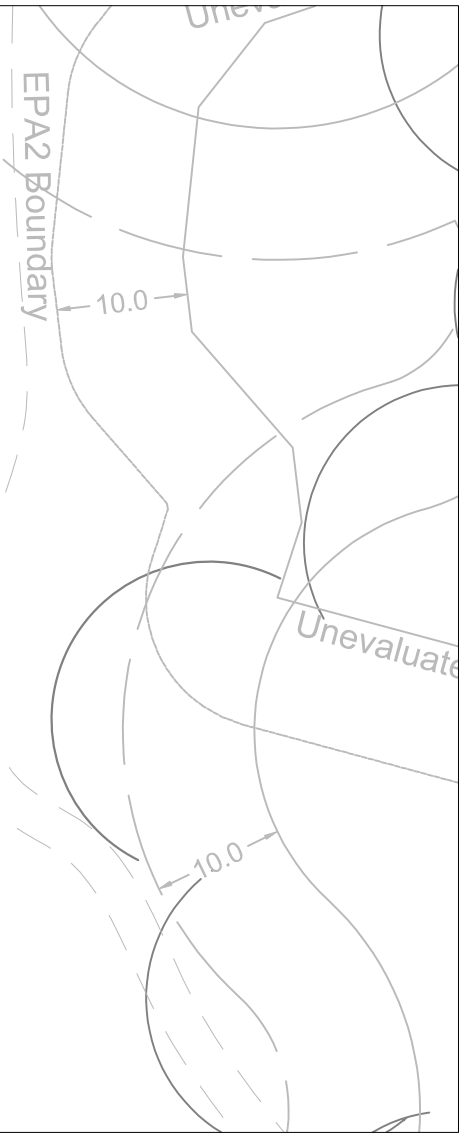

Existing Building

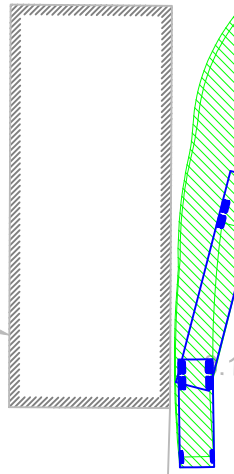

REV.	SUBMISSION	DATE	INITIAL

**4848 Mayfield Road  
 Traffic Impact Study**



DESIGN	DRAWN	CHECKED	CONTRACT No.
SCALE:	DRAWING NUMBER		WB-20 - Tractor & Semi-Trailer Egress # 14
DATE:			

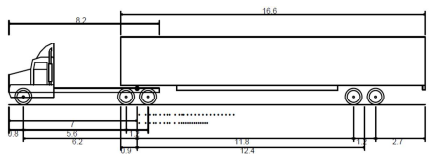

WB-20-180 - Tractor & Semi-Trailer  
 Overall Length 22.700m  
 Overall Width 2.600m  
 Overall Body Height 3.730m  
 Min Body Ground Clearance 0.435m  
 Track Width 2.600m  
 Lock-to-lock time 4.00s  
 Curb to Curb Turning Radius 14.300m

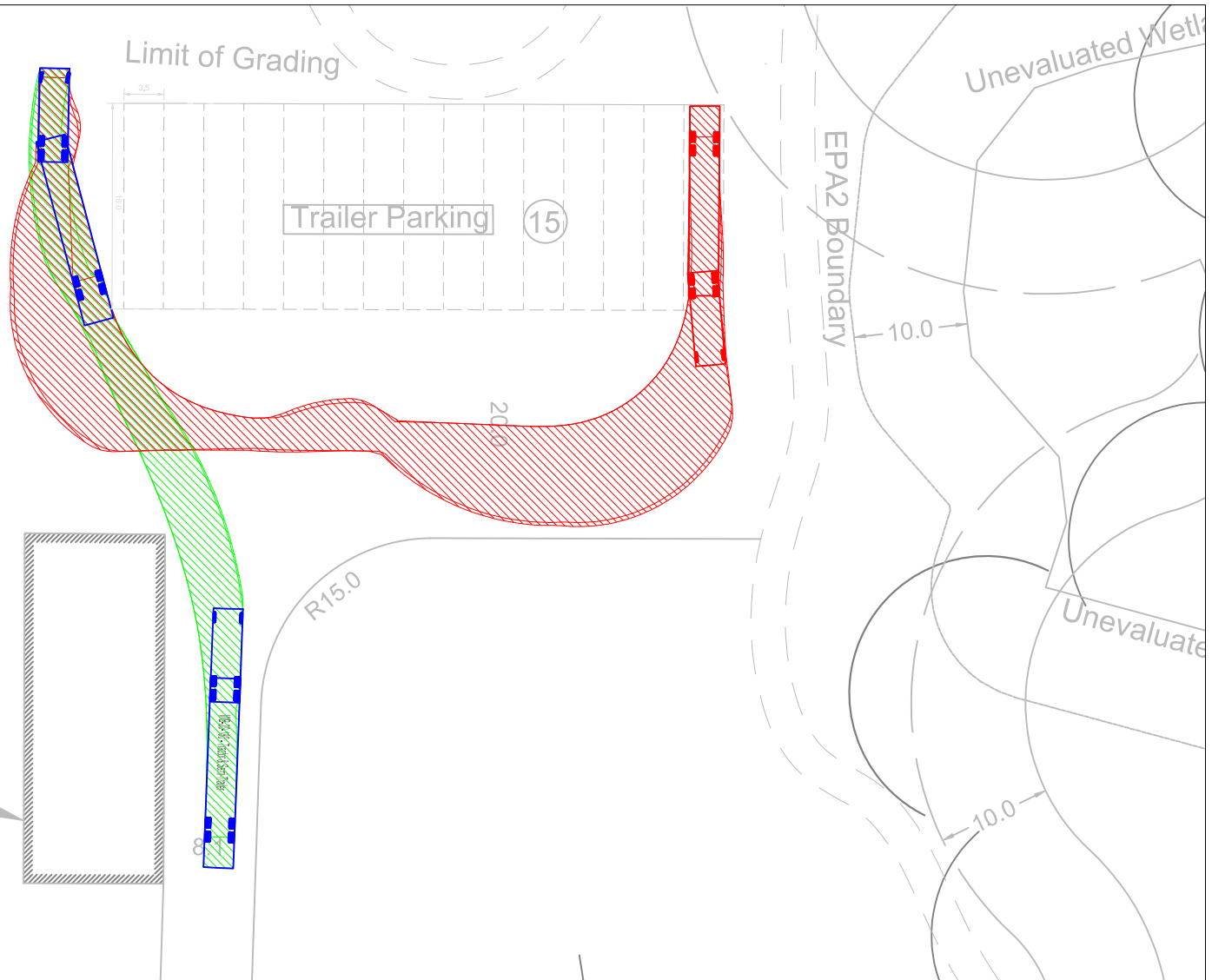

Existing Building

**4848 Mayfield Road  
 Traffic Impact Study**



DESIGN	DRAWN	CHECKED	CONTRACT No.
SCALE:	DRAWING NUMBER		WB-20 - Tractor & Semi-Trailer Ingress # 15
DATE:			

REV.	SUBMISSION	DATE	INITIAL

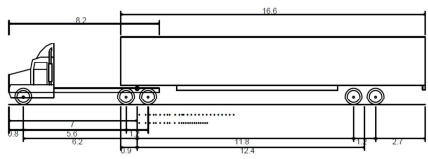

WB-20-180 - Tractor & Semi-Trailer  
 Overall Length 22.700m  
 Overall Width 2.600m  
 Overall Body Height 3.730m  
 Min Body Ground Clearance 0.435m  
 Track Width 2.600m  
 Lock-to-lock time 4.00s  
 Curb to Curb Turning Radius 14.300m



Existing Building

Trailer Parking 15

EPA2 Boundary

Unevaluated

REV.	SUBMISSION	DATE	INITIAL

**4848 Mayfield Road  
 Traffic Impact Study**



DESIGN	DRAWN	CHECKED	CONTRACT No.
SCALE:	DRAWING NUMBER		WB-20 - Tractor & Semi-Trailer Egress # 15
DATE:			